

POLINI KIDS FUN Masha and the Bear

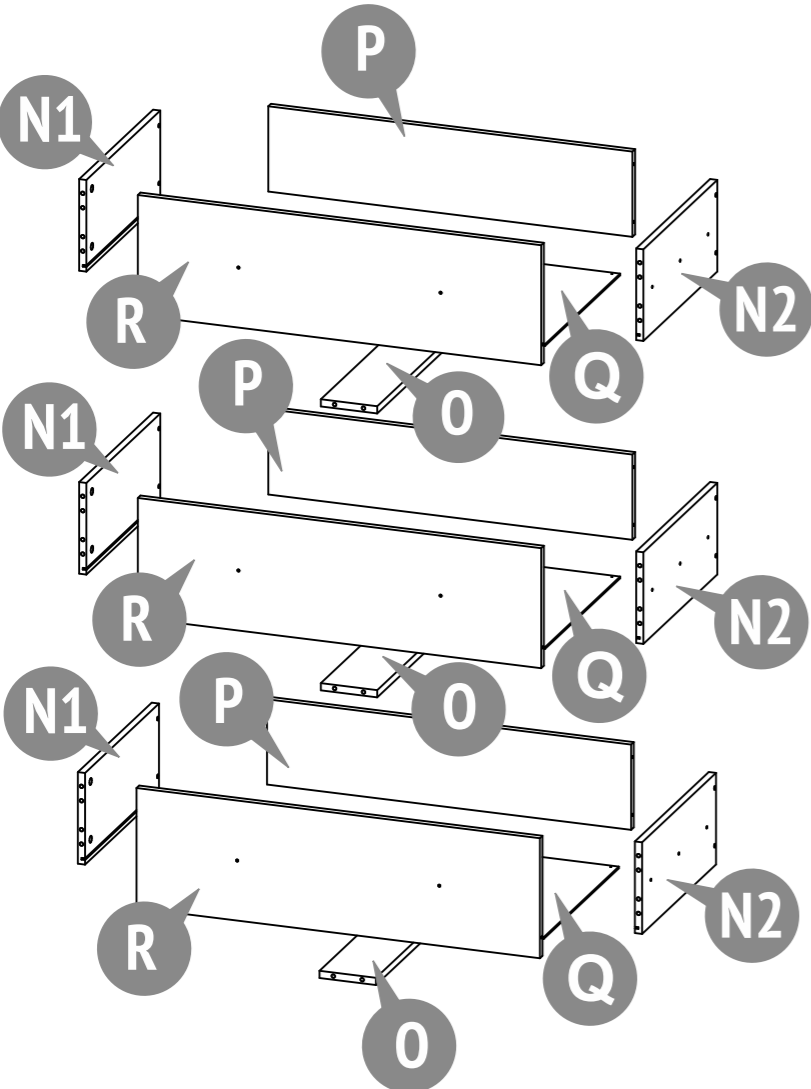

Number on the picture Nummer in der Zeichnung Nummer op figuur Nombre à la figure Numero en el dibujo Il numero alla figura Número na figura Номер на рисунке الرقم على الرسمة	Number of parts in the product Stückzahl der Teile im Produkt Aantal componenten in het product Nombre des détails du produit Cantidad de elementos del producto La quantità dei dettagli nel prodotto Quantidade de peças Количество деталей в изделии كمية الأجزاء بالمنج	Parts description			Laying / Verpackung / Pakking / Pose / El embalaje / Posa / Estilo / Укладка / ترتيب		
		Bezeichnung Onderdelen namen Names des pièces	Nombre de los elementos La nomenclatura dei dettagli Designação das peças Наименование деталей تسمية الأجزاء			Box / Karton / Plaats / Placer / Lugar / Il posto / Espaço / Место المكان	
						1	2
A1	1	Side wall Seitenwand Zijwand	Paroi latérale Lateral de planchar La parete a fianco	Prancha lateral Боковая стенка الجدار الجانبي	●		
A2	1	Side wall Seitenwand Zijwand	Paroi latérale Lateral de planchar La parete a fianco	Prancha lateral Боковая стенка الجدار الجانبي	●		
B	1	Cover Deckel Kap	Capot Cubierta Cappuccio	Cobertura Колпак السقف		●	
C	1	Base Basis Basis	Bas e Base Base	Base Цоколь قاعدة		●	
C1	1	Base Basis Basis	Bas e Base Base	Base Цоколь قاعدة		●	
D	1	Bottom Boden Bodem	Fond Fondo Fondo	Fundo Дно الجزء السفلي		●	
G	2	Back panel Rückwand Achterpaneel	Panneau arrière El panel trasero Il pannello posteriore	Painel traseiro Задняя панель اللوحة الخلفية		●	
N1	3	Drawer side wall, left / linke Schubladenseitenwand / Linder zijwand van de doos La paroi latérale gauche de la caisse / Pared de cajón lateral izquierda Fiancata sinistra del cassetto / A parede lateral esquerda da caixa Боковая стенка ящика левая / الجدار الجانبي اليسار للدرج /			●		
N2	3	The right side wall of the drawer / Die rechte Seitenwand der Schublade / De rechter zijkant van de lade / Côté droit tiroir / Pared lateral derecha del cajón / La parete destra a fianco del cassetto / Parede lateral da gaveta direita جرذلان ميلاً يميناً رانجلا /			●		
O	3	Stay bar Tragebalken Versterkingbar	Le barre de renforcement Pieza de refuerzo Listello di rinforzo	Barra de reforço Брусok усиления الشريط للتعزير	●		
P	3	Drawer rear wall Schubladenrueckwand Lade achterpaneel	Le panneau arrière de la caisse Panel trasero del cajón Pannello posteriore del cassetto	Painel traseiro de caixa Задняя панель ящика الوحة الدرج الخلفية		●	
Q	3	Box bottom Boden der Schublade Lade bodem	Base du tiroir Fondo del cajón Base del cassetto	Fundo da gaveta Дно ящика قاع الصندوق	●		
R	3	Box face Fassade der Schublade Ladegevel	Façade du tiroir La fachada del cajón Facciata del cassetto	A fachada da gaveta Фасад ящика واجهة الصندوق		●	
T	1	Back panel Laengsriegel Verbindingsbalk	La barre de connexion Barra de conexión Travetto di accoppiamento	Feixe de conexão Соединительный брус الشريط للانضمام	●		
	1	Set of fittings Satz Beschläge Hang-en-sluitwerk	Kit d'accessoires Conjunto de los accesorios Il completo della forniture	Kit de ferragens Комплект фурнитуры زاوية معدنية		●	

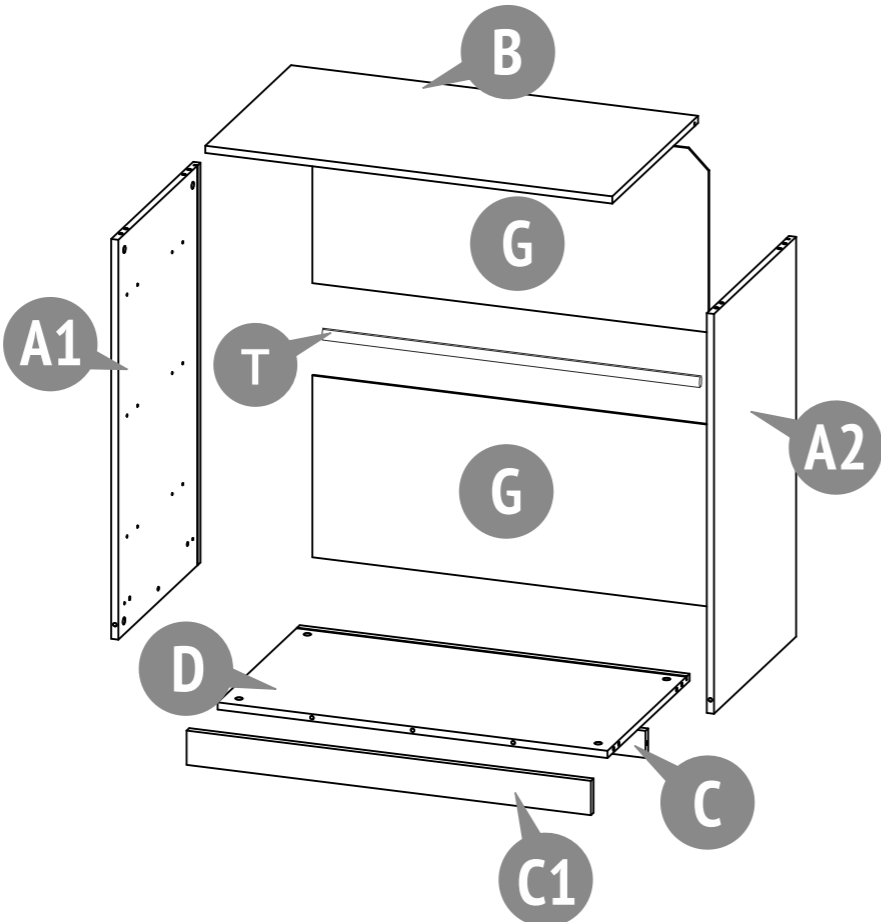
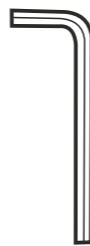
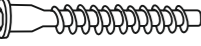

001 12 x 
 Drywall screw 7 x 50
 Confirmat Schraube 7 x 50
 Confirmaatschroef 7 x 50
 Vis Confirmat 7 x 50
 Tornillo drywall 7 x 50
 Vite Confirmat 7 x 50
 Parafuso de drywall 7 x 50
 Винт-конфирмат 7 x 50
 مسمار كونفيرمات

002 24 x 
 Eccentric pin
 Exzenterstift
 Stengel van excentriek
 Tige d'excentrique
 El pasador excéntrico
 La barra dell'excentrico
 Rosca soberba
 Шток эксцентрика
 (إكسنترك) محور قرص لا متمرکز

003 24 x 
 Eccentric
 Exzenter
 Excentriek
 Excentrique
 El excéntrico
 L'excentrico
 Tambor
 Эксцентрик
 (إكسنترك) قرص لا متمرکز

004 31 x 
 Pin 10x30
 Dübel 10x30
 Treknagel 10x30
 Cheville en bois 10x30
 Clavija 10x30
 Spina di legno 10x30
 Caviilha 10x30
 Шкант 10 x 30
 دسار 30 x 8

005 6 x 
 Handle
 Griff
 Handvat
 Poignée
 Manejar
 Maniglia
 Puxador
 Ручка
 التعامل مع

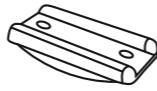
006 6 x 
 Bearing
 Fuß
 Druklager
 Butée
 Parada
 Cuscinetto
 Rolamento
 Подпятник
 تحمل

007 24 x 
 Screw M6 x 12
 Holzschraube M6 x 12
 Schroef M6 x 12
 Vissez M6 x 12
 El tornillo M6 x 12
 La vite M6 x 12
 Parafuso M6 x 12
 Винт M6 x 12
 م6 x 12 قلاووظ

008 20 x 
 Screw 4 x 13
 Holzschraube 4 x 13
 Schroef 4x13
 Vis 4 x 13
 El tornillo 4 x 13
 La vite 4 x 13
 Parafuso 4 x 13
 Шуруп 4 x 13
 4 x 13 قلاووظ

009 12 x 
 Rear wall mounting
 Rückwandbefestigung
 Achterwand montage
 Fixateur de la paroi arrière
 La lengüeta de la parte posterior de la pared
 Il fissatore della parete posteriore
 Fixador de parede traseira
 Фиксатор задней стенки
 مثبت الجدار الخلفي

010 18 x 
 Nail
 Nagel
 Spijker
 Le clou
 El clavo
 Chiodo
 Pregão
 Гвоздь
 مسمار

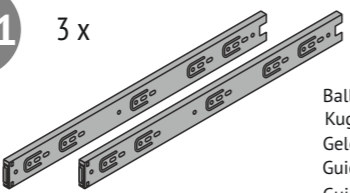
011 3 x 
 Ball-bearing guide L=450
 Kugelführung L=450
 Geleiderail (kogellagers) L=450
 Guidage à billes L = 450
 Guida a sfera L=450
 Guia de rolo L=450
 Направляющая шариковая L=450
 Diapositiva del cajón de rodamientos de bolas L=450
 قطبان حديدي بالكرات - طول 450

012 2 x 
 Conical shim
 Konus Unterlegscheibe
 Conische ring
 Rondelle conique
 Arandela cónica
 Rondella conica
 Arruela cónica
 Шайба коническая
 غسالة مخروطية

013 6 x 
 Screw 4 x 30
 Holzschraube 4 x 30
 Schroef 4x30
 Vis 4 x 30
 El tornillo 4 x 30
 La vite 4 x 30
 Parafuso 4 x 30
 Шуруп 4 x 30
 قلاووظ 4 x 30

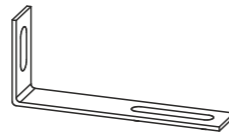
014 2 x 
 Fastening corner
 Befestigungsecke
 Bevestiging hoek
 Equerre murale
 Rincón para fijación
 Angolo per il fissaggio
 Canto para fixação
 Уголок крепежный
 الزاوية لتحديد

1

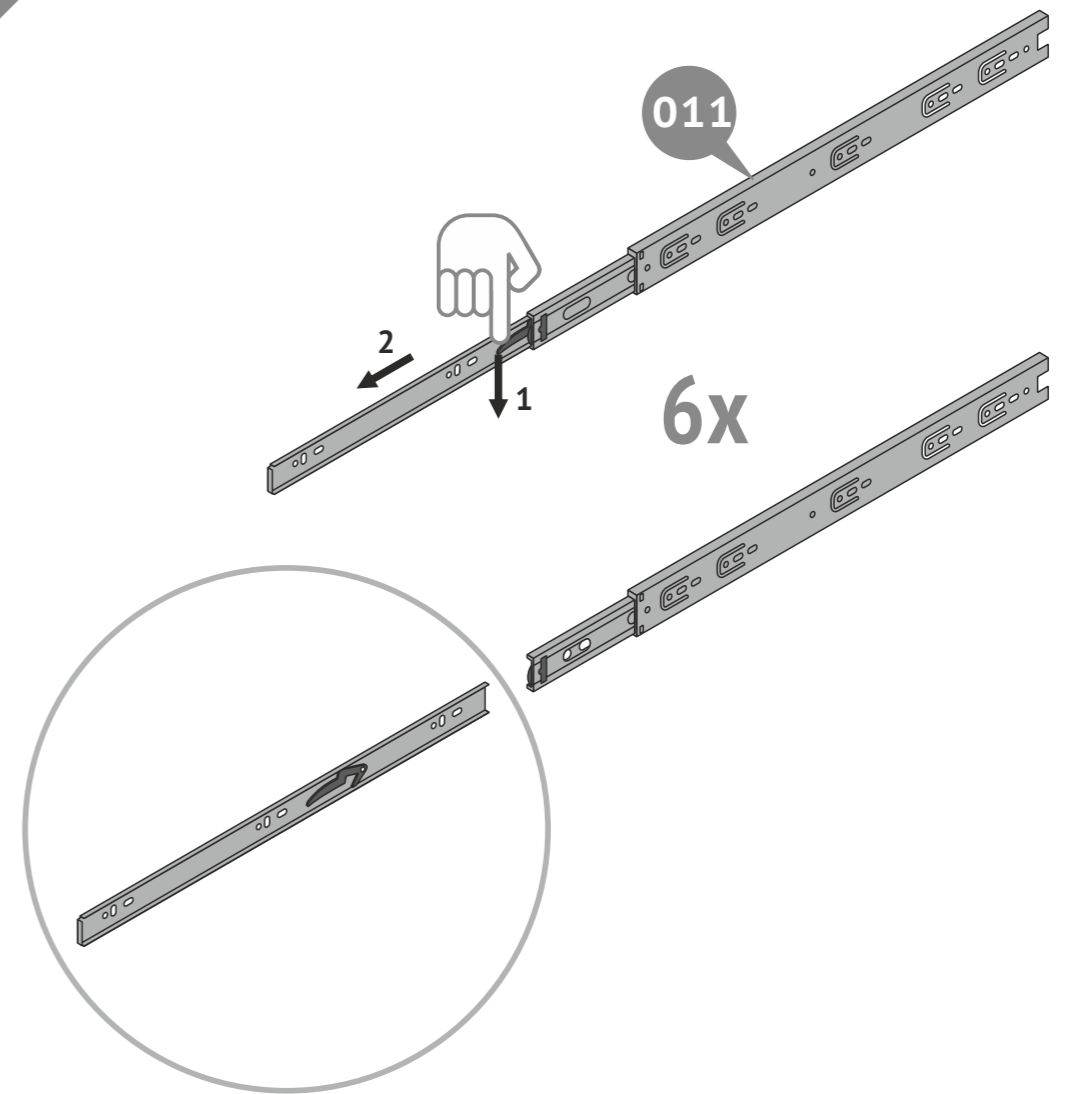

2

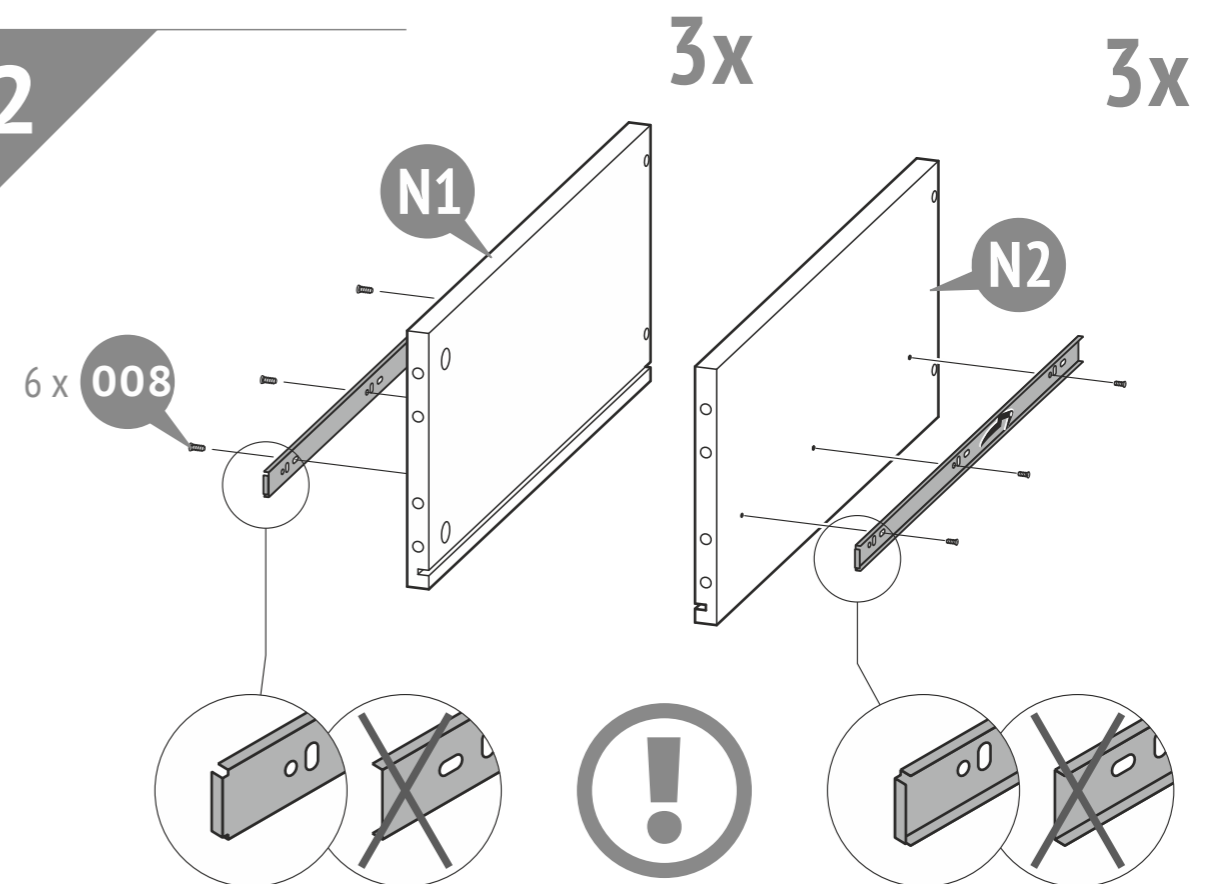

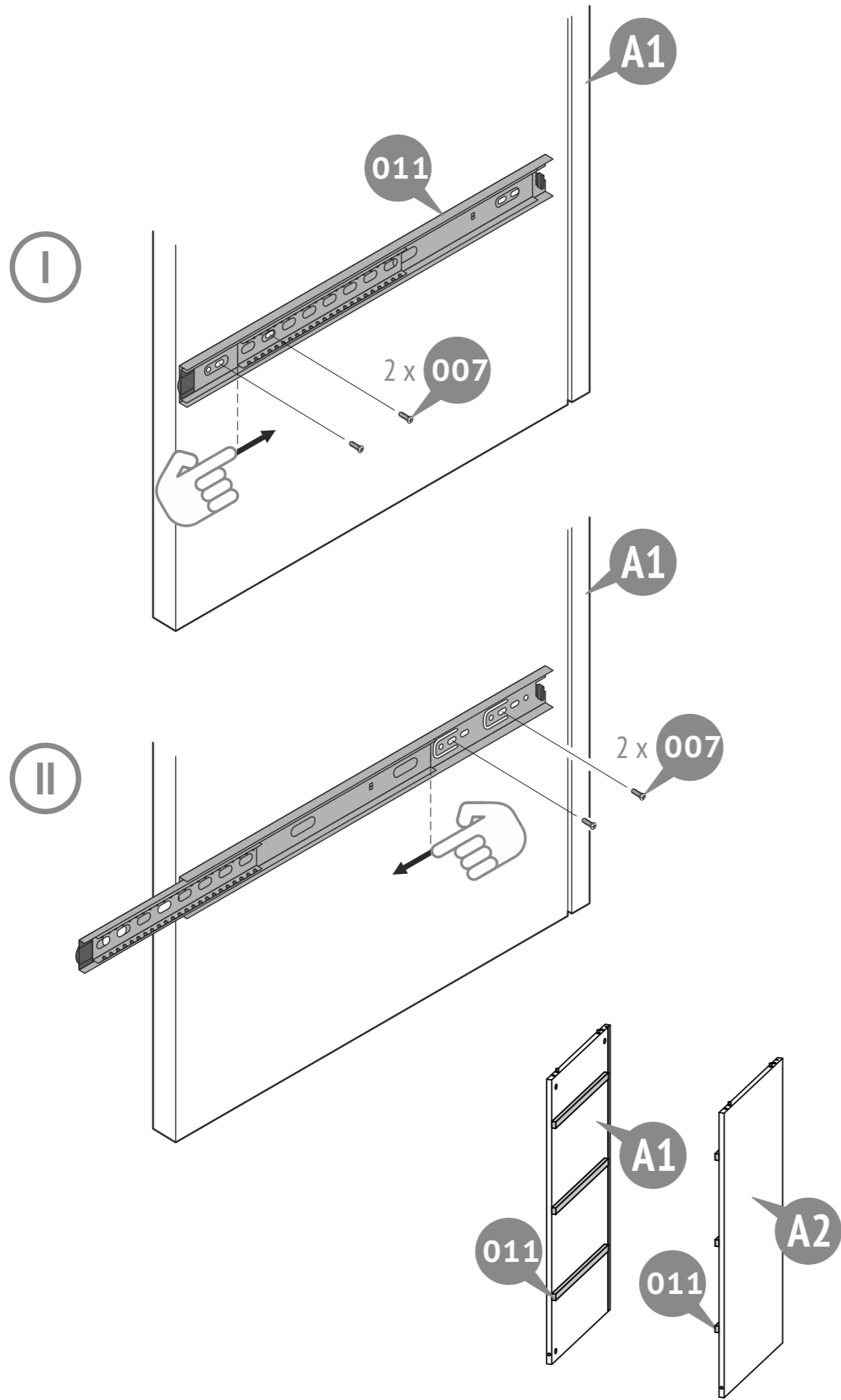

21

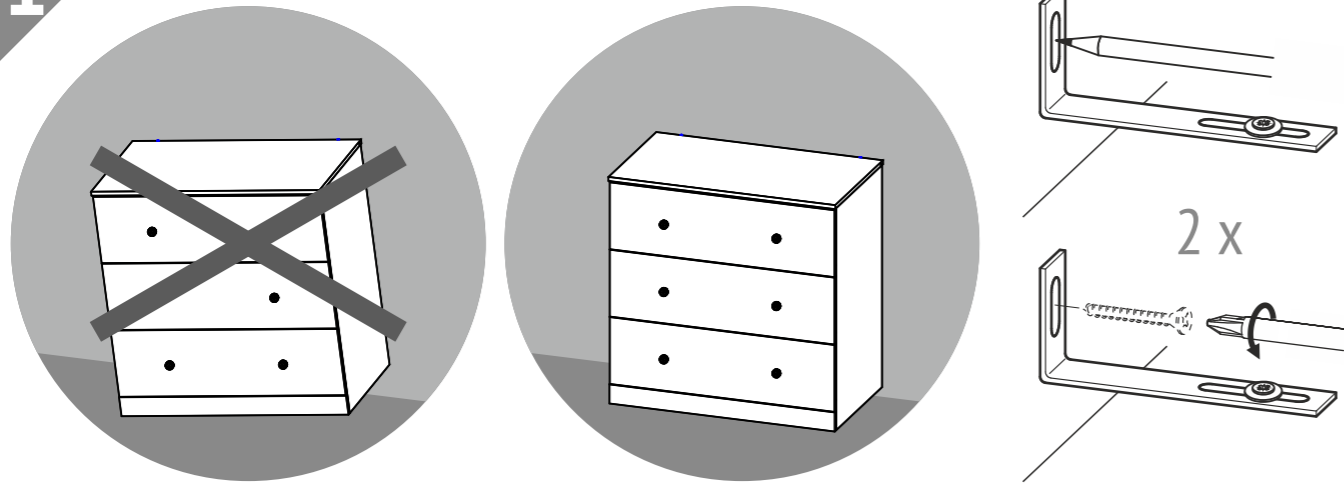

- EN**
- Do not use the product in an unsecured position.
 - To avoid overturning, the product must be attached to the wall.
 - The fasteners are not included, their choice is determined by the type of your wall.
 - To install the fixing elements, you may need additional equipment and tools not specified in this manual.



- DE**
- Verwenden Sie das Produkt nur, wenn es gegen Umkippen gesichert ist.
 - Um ein Umkippen zu vermeiden, empfehlen wir, es an der Wand zu befestigen.
 - Die Befestigungselemente werden nicht mitgeliefert. Die Art der benötigten Materialien wird durch die Beschaffenheit der Wand bestimmt.
 - Um zu fixieren, benötigen Sie ggf. zusätzliches Werkzeug, das nicht in der Anleitung aufgeführt wurde.

- NL**
- Het product moet in de ontgrendelde positie NIET gebruikt worden.
 - Om het kantelen te voorkomen moet het product aan de wand worden gehecht.
 - De bevestigingsmiddelen worden met het product niet meegeleverd; de keuze daarvan wordt door het type van uw muur bepaald.
 - Om de bevestigingsmiddelen te installeren kunnen aanvullende faciliteiten en gereedschappen nodig zijn die in deze handleiding niet worden vermeld.

- FR**
- Ne pas utiliser le produit sans la fixation murale.
 - Pour éviter tout basculement, il est nécessaire de fixer le produit au mur.
 - Les éléments de fixation ne sont pas fournis. Utiliser des vis et des chevilles adaptés à votre support mural.
 - Pour installer les éléments de fixation suivre les instructions de montage.

- ES**
- NO ES PERMITIDO el uso del producto en posición de desbloqueo.
 - Para evitar vuelcos, hace falta sujetar el producto a la pared.
 - Los elementos de sujeción no forman parte del suministro de producto, y su elección se determina por el tipo de la pared que Usted tiene.
 - La instalación de los elementos de sujeción puede requerir equipos y herramientas adicionales que no figuran en las instrucciones presentes.

- IT**
- È INAMMISSIBILE l'esercizio dell'articolo in posizione non fissata.
 - Per evitare il ribaltamento è necessario fissare il prodotto al muro.
 - Gli elementi di fissaggio non sono la parte della composizione della fornitura dell'articolo, la loro scelta dipende dal tipo della Sua parete.
 - Per installare gli elementi di fissaggio potrebbero essere necessari l'attrezzamento complementare e gli strumenti che non sono indicati nel manuale presente.

- P**
- A utilização do produto na posição de desbloqueio NÃO É PERMITIDA.
 - Para evitar o tombo, você precisa segurar o produto na parede.
 - Os elementos de sujeição não são fornecidos com o produto, a sua escolha é determinada pelo tipo de parede que você tem.
 - A instalação dos elementos de sujeição pode exigir equipamentos e ferramentas adicionais que não estão listados nas presentes instruções.

- RU**
- НЕ ДОПУСКАЕТСЯ эксплуатация изделия в незафиксированном положении.
 - Во избежание опрокидывания изделие необходимо прикрепить к стене.
 - Крепежные элементы не входят в комплект поставки изделия, их выбор определяется типом Вашей стены.
 - Для установки крепежных элементов может понадобится дополнительное оборудование и инструменты, не указанные в данной инструкции.

AE

- لا يسمح باستخدام المنتج إن لم يكن مثبتاً.
- الانقلاب، يجب إرفاق المنتج بالجدار لتجنب.
- لا تدخل عناصر التثبيت ضمن العبوة ويتم اختيار نوعها وفقاً لنوع الحائط لديكم.
- من الممكن أن تحتاجوا إلى معدات أو آلات إضافية غير مذكورة في هذه التعليمات لتثبيت عناصر التثبيت.

4

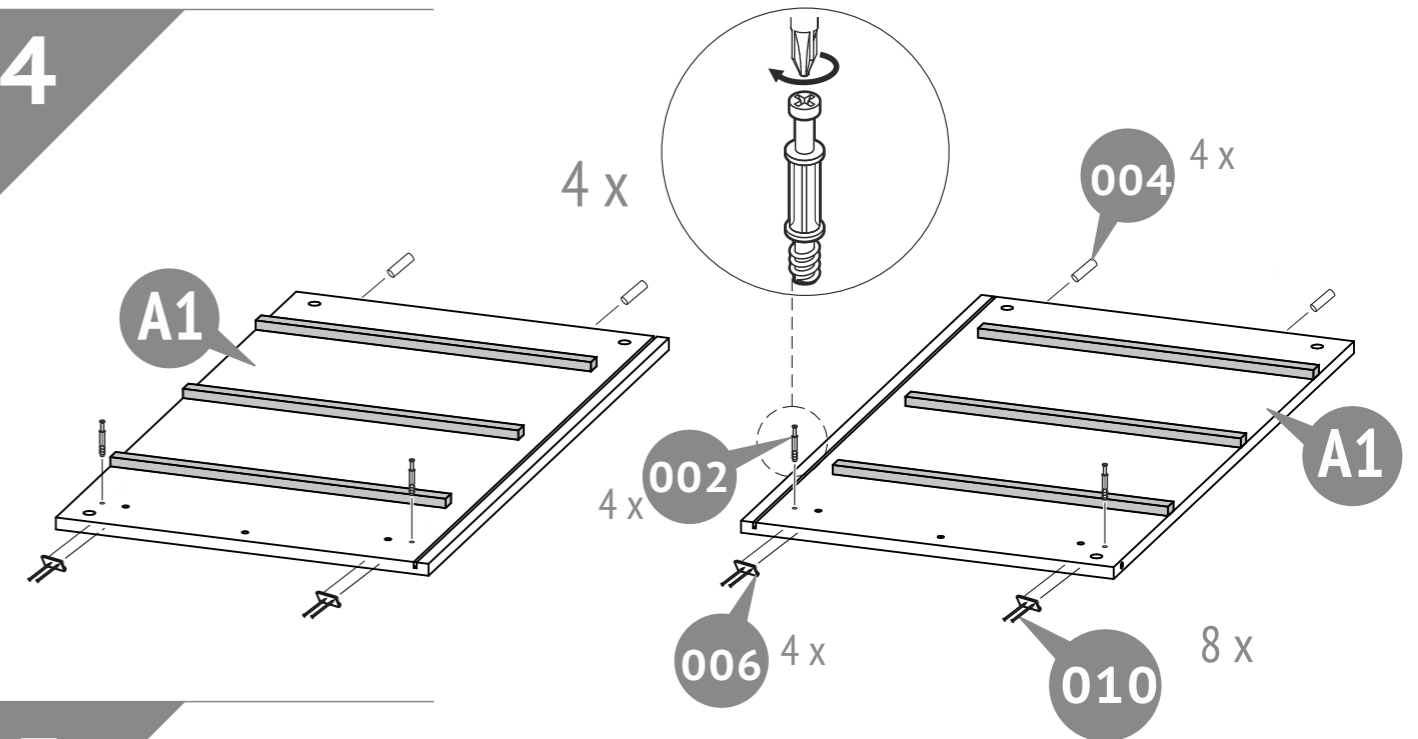

5

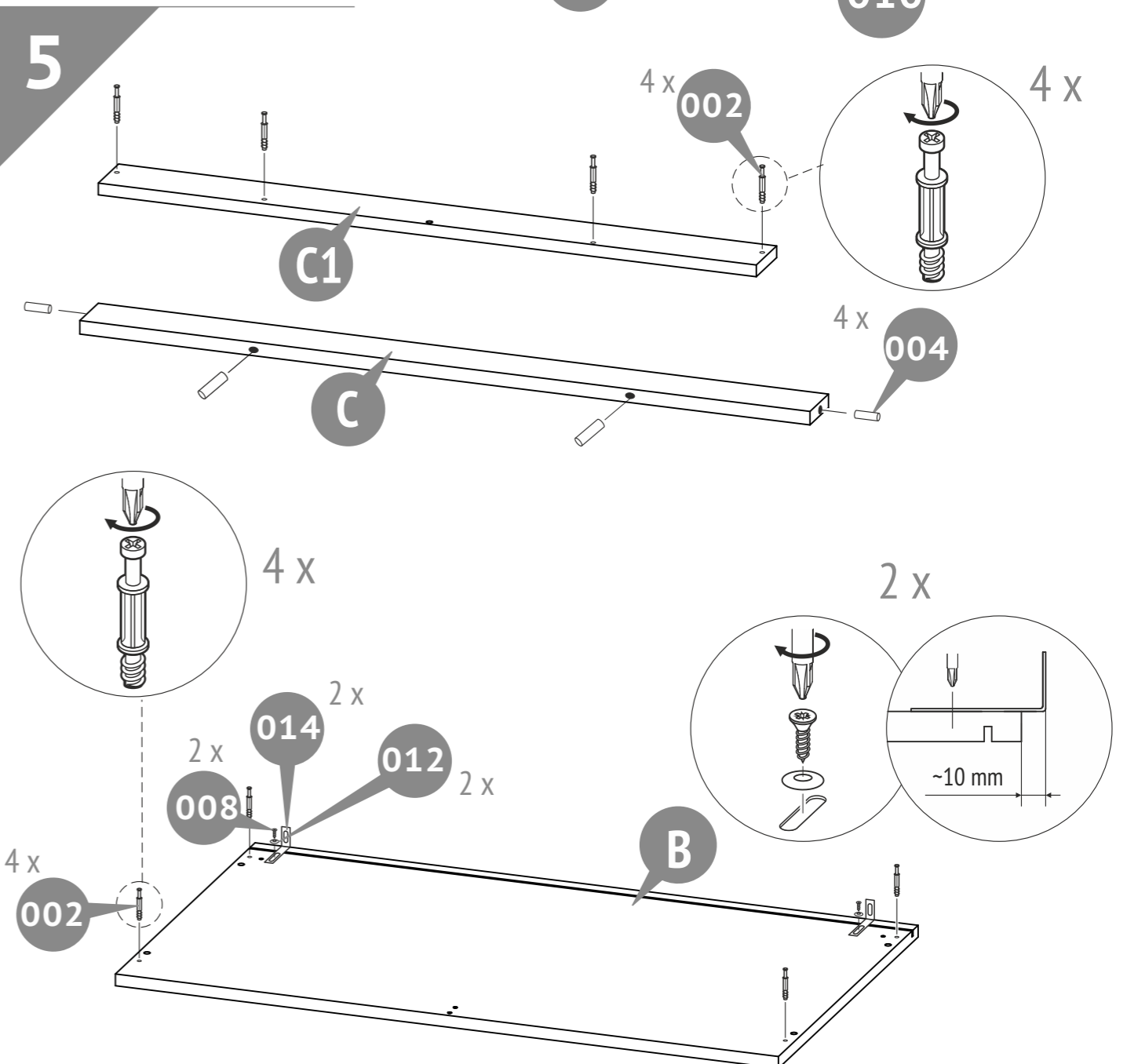

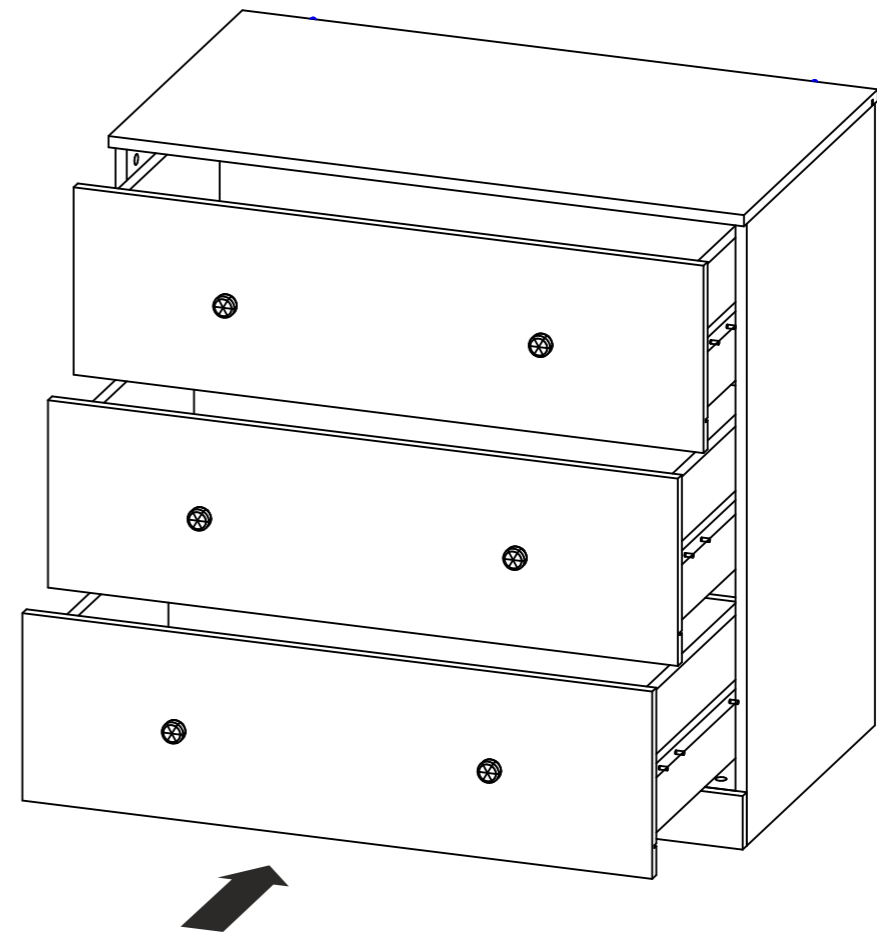
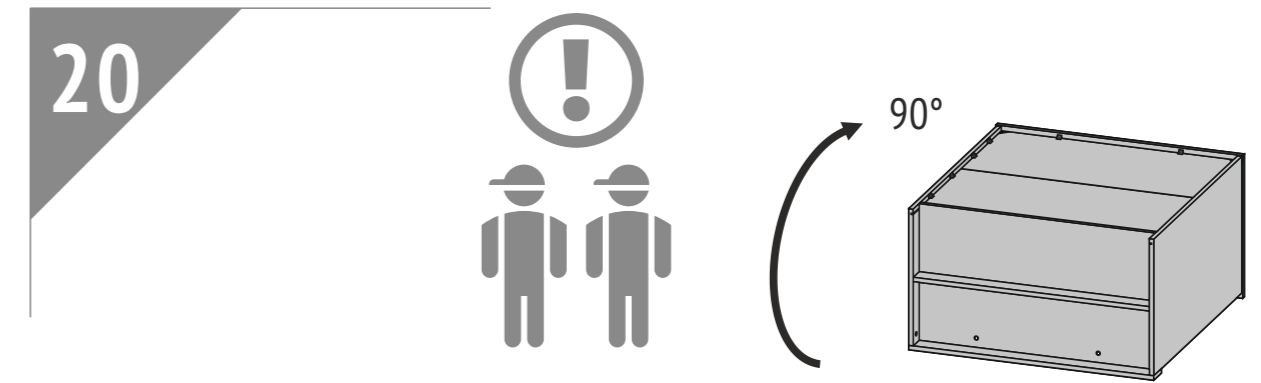
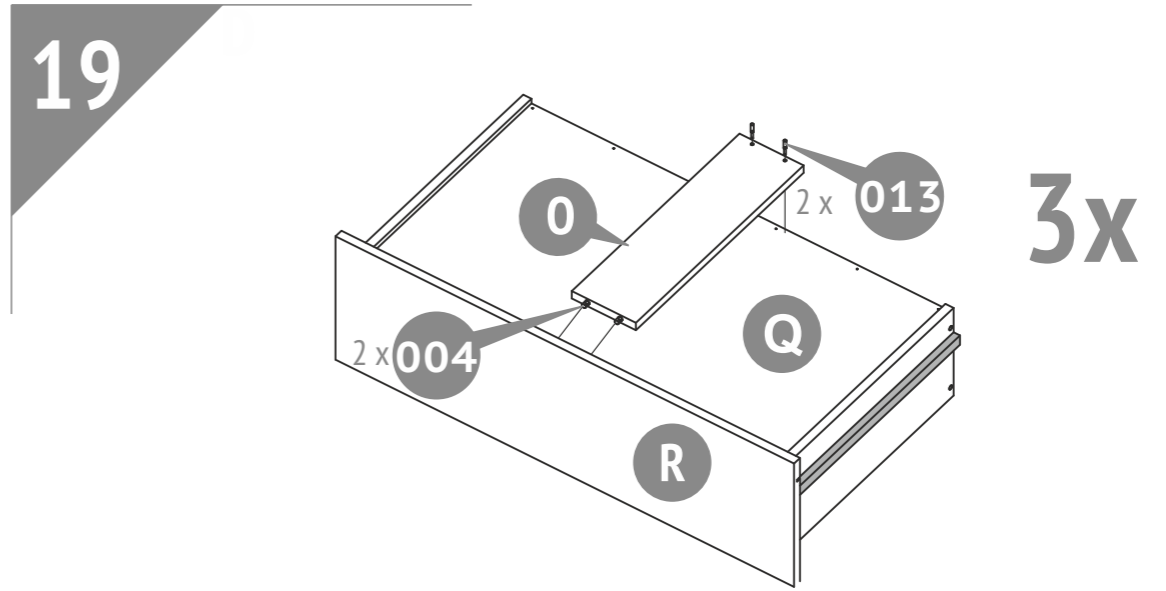
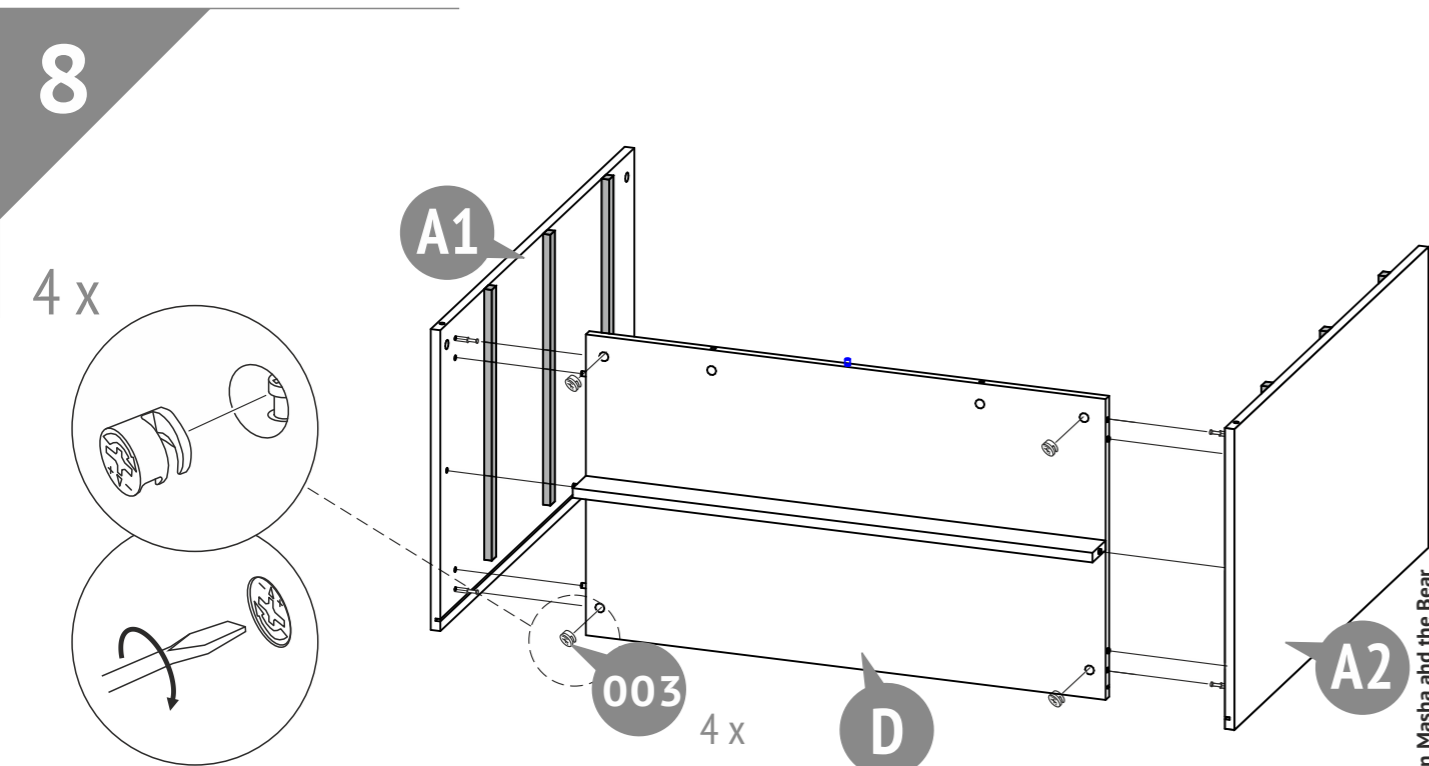
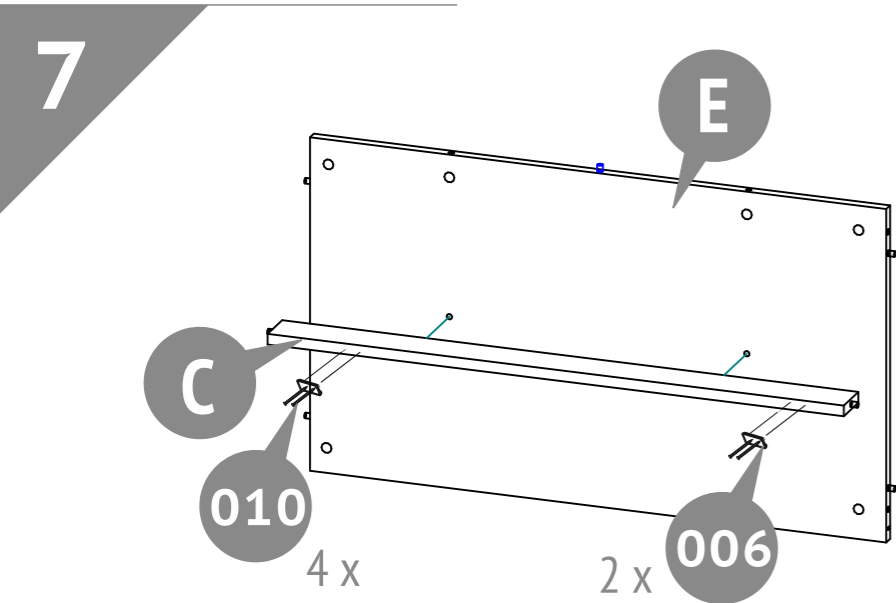
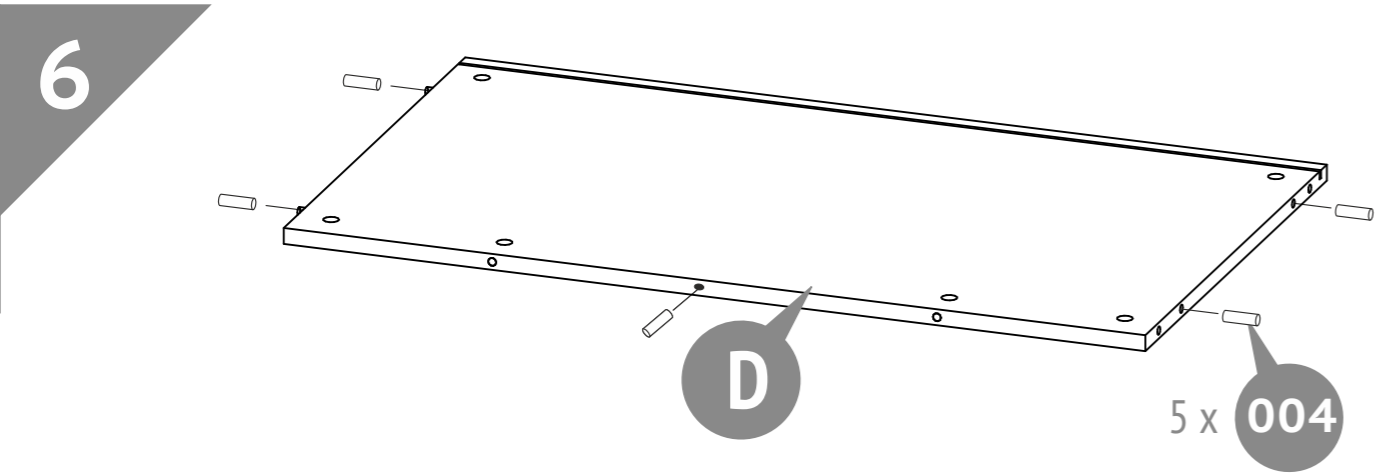

17

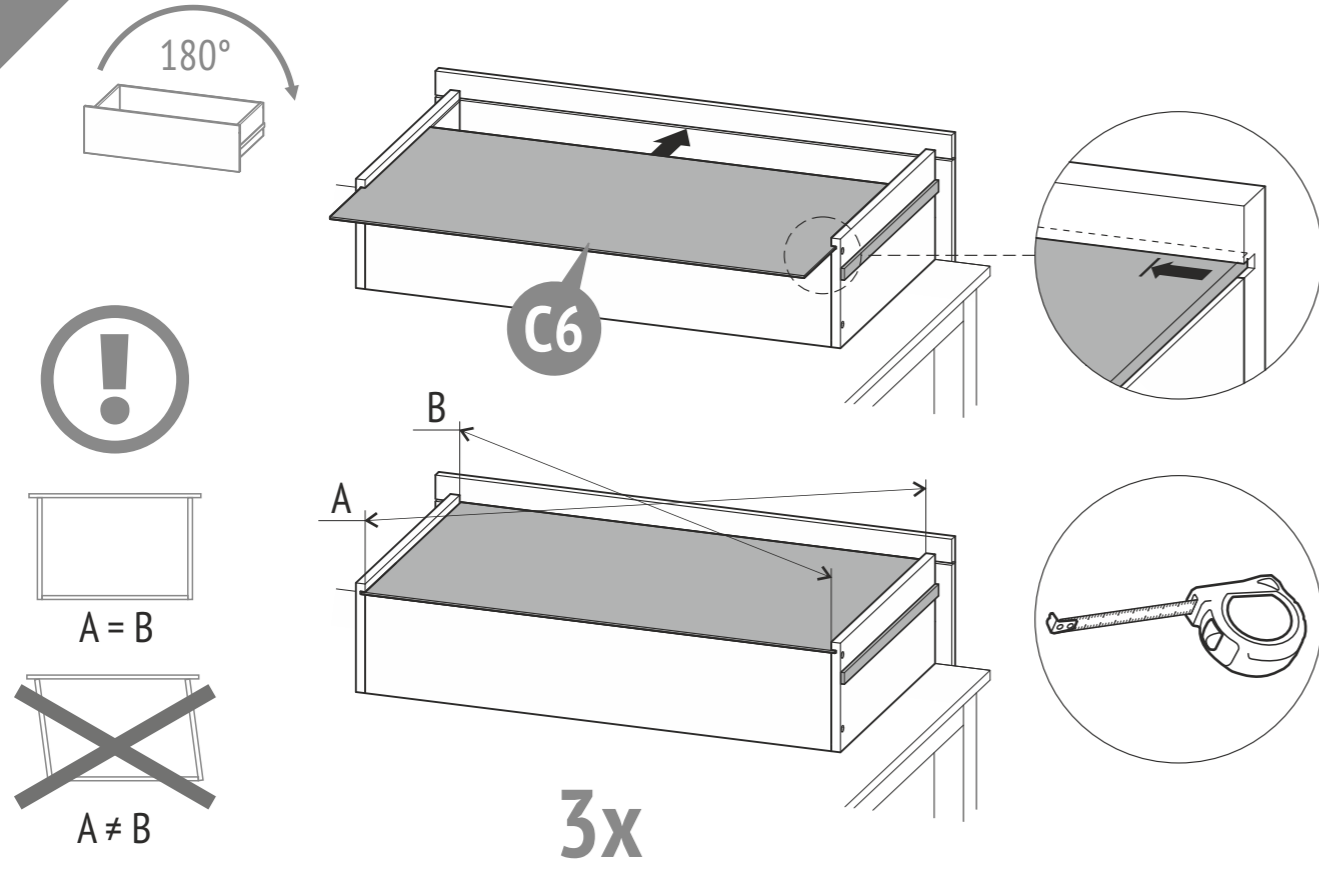

9

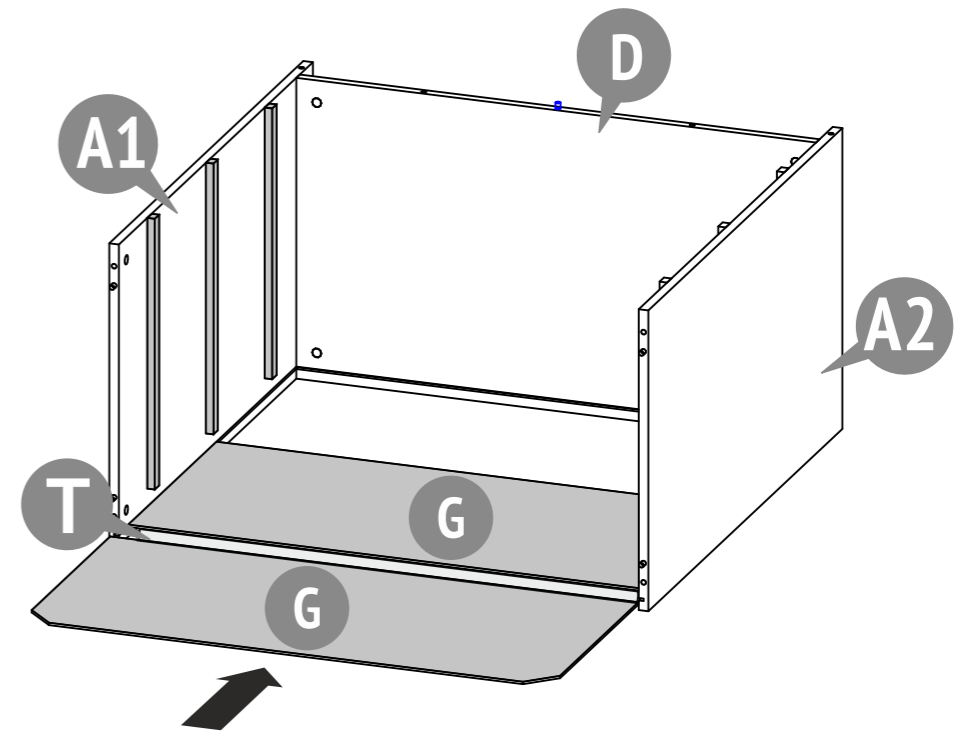

18

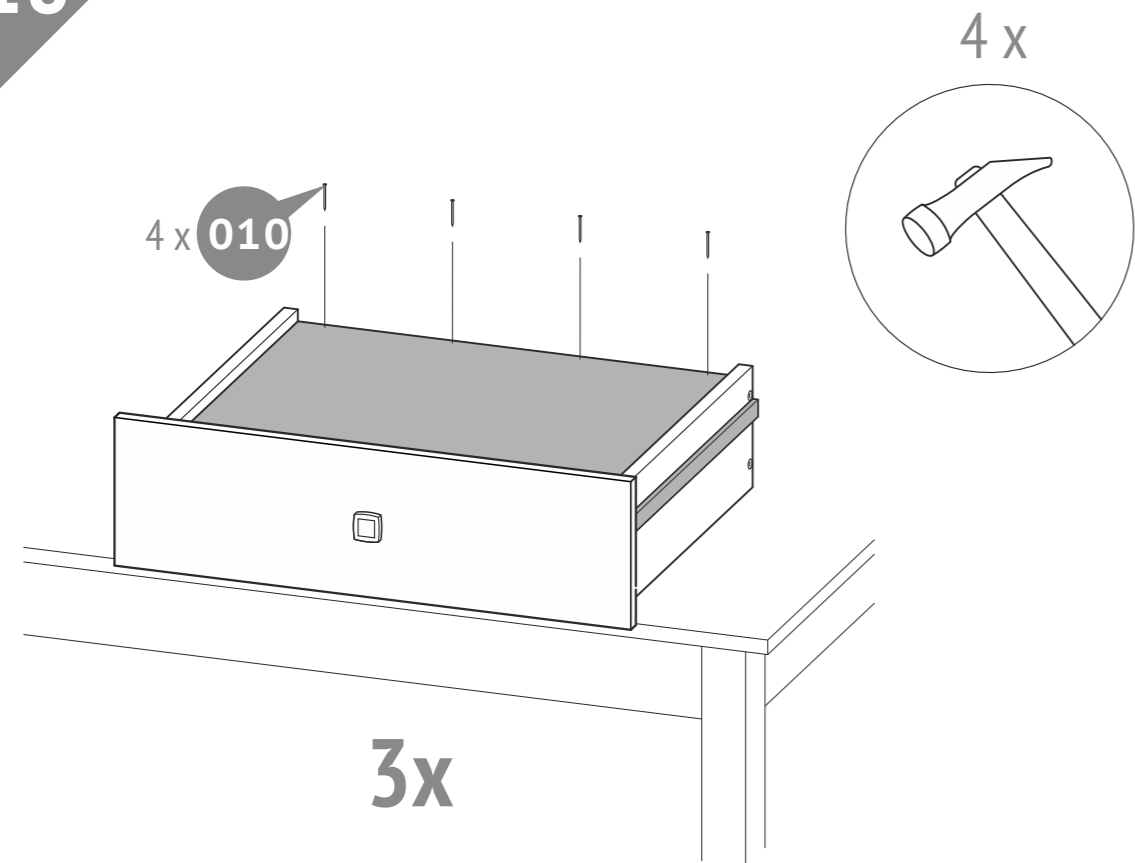

10

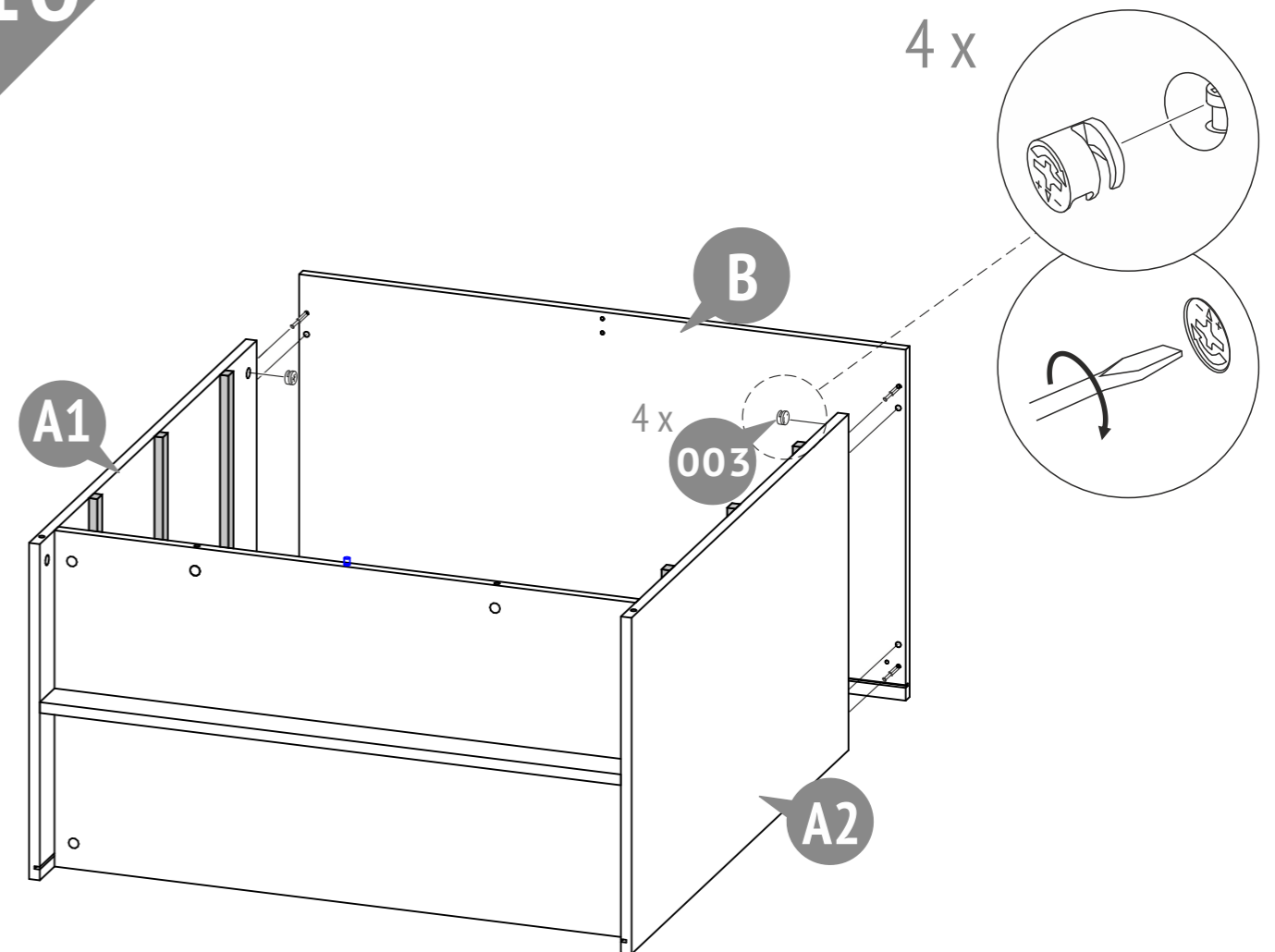

11

4 x

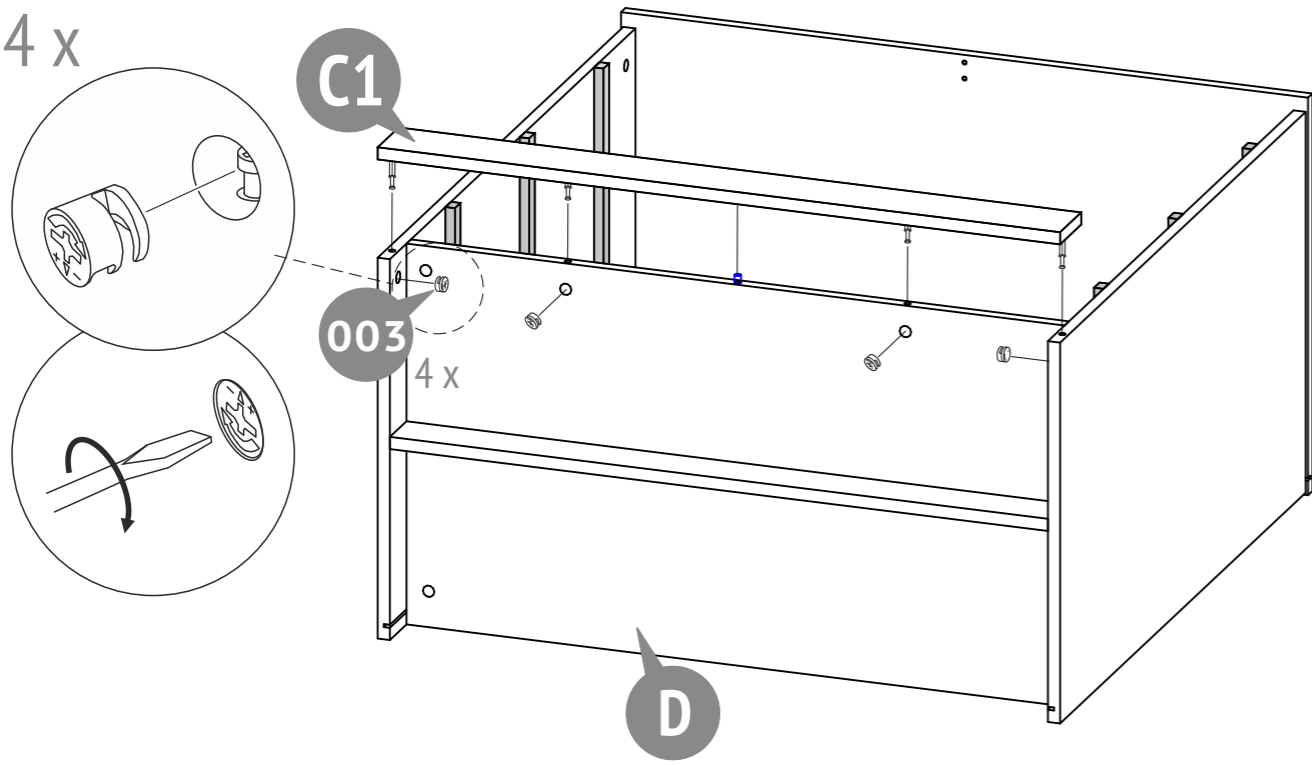

13

4 x 002

R

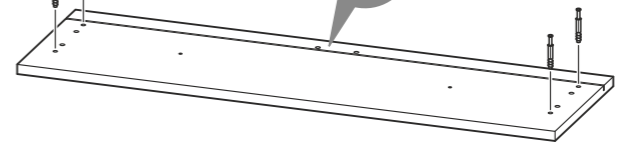

12

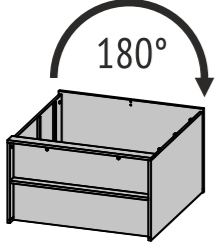
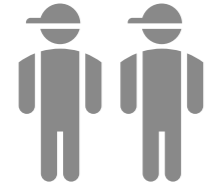

12 x

12 x

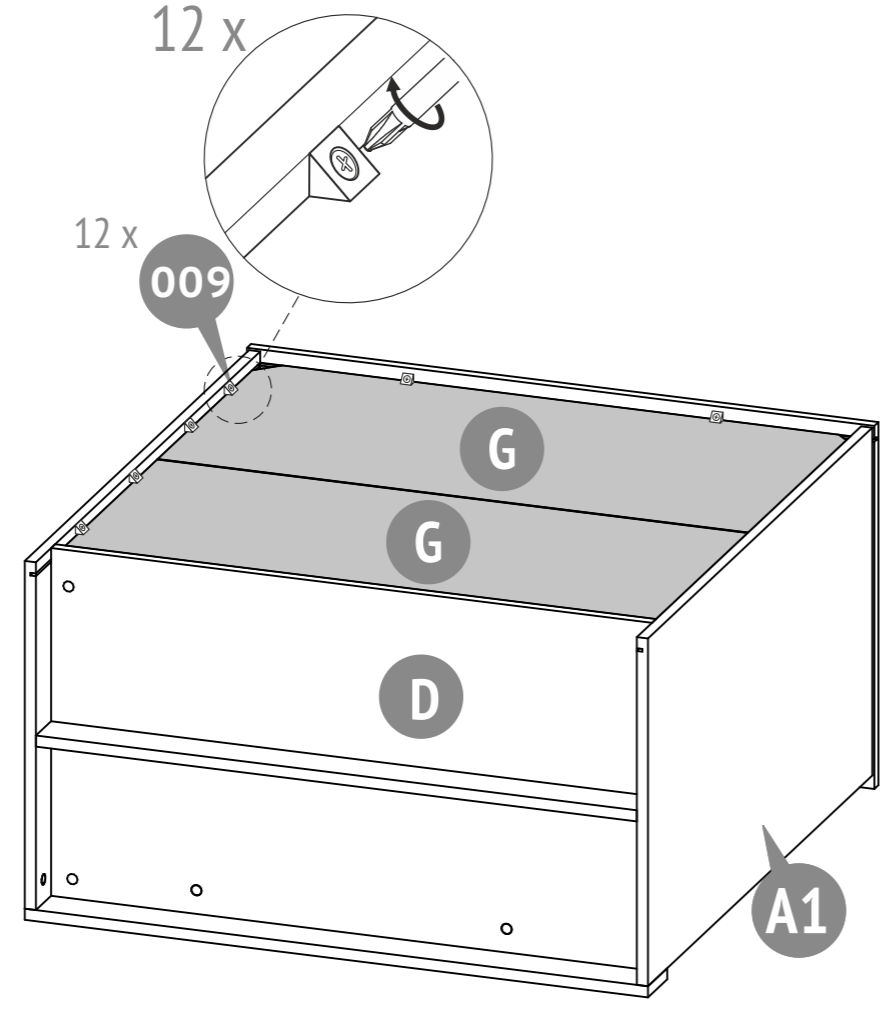

14

3x

N1

2 x 004

N2

2 x 004

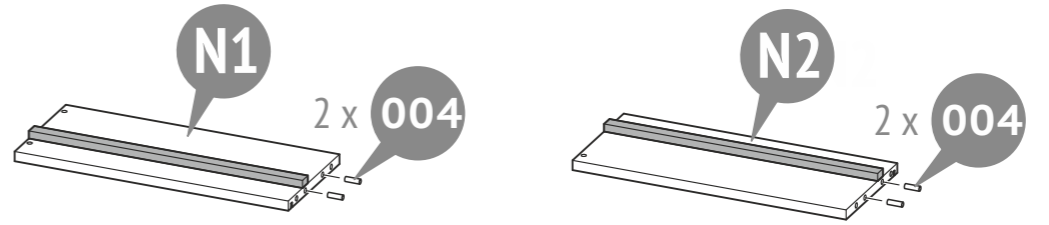

15

P

3x

4 x 001

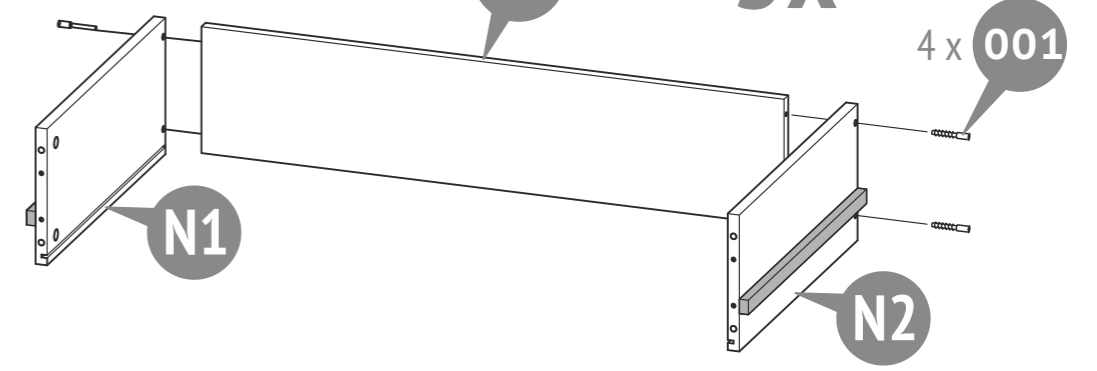

16

3x

2 x 005

003

4 x

