

Polini kids Simple 304

EN Baby cot

DE Kinderbett

NL Babybedje

FR Lit d'enfant

ES Cama juvenil

IT Il letto da bambini

P Cama juvenil

RU Кроватка детская

AE طفل المهد

Polini kids Simple 304

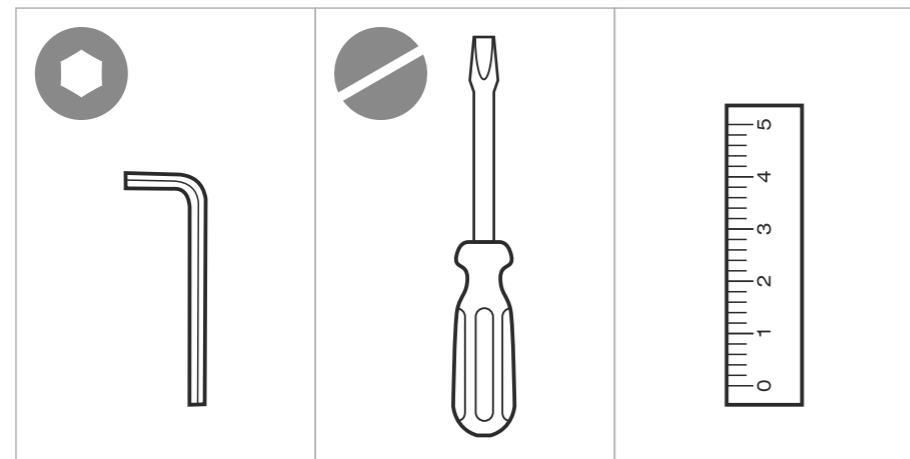
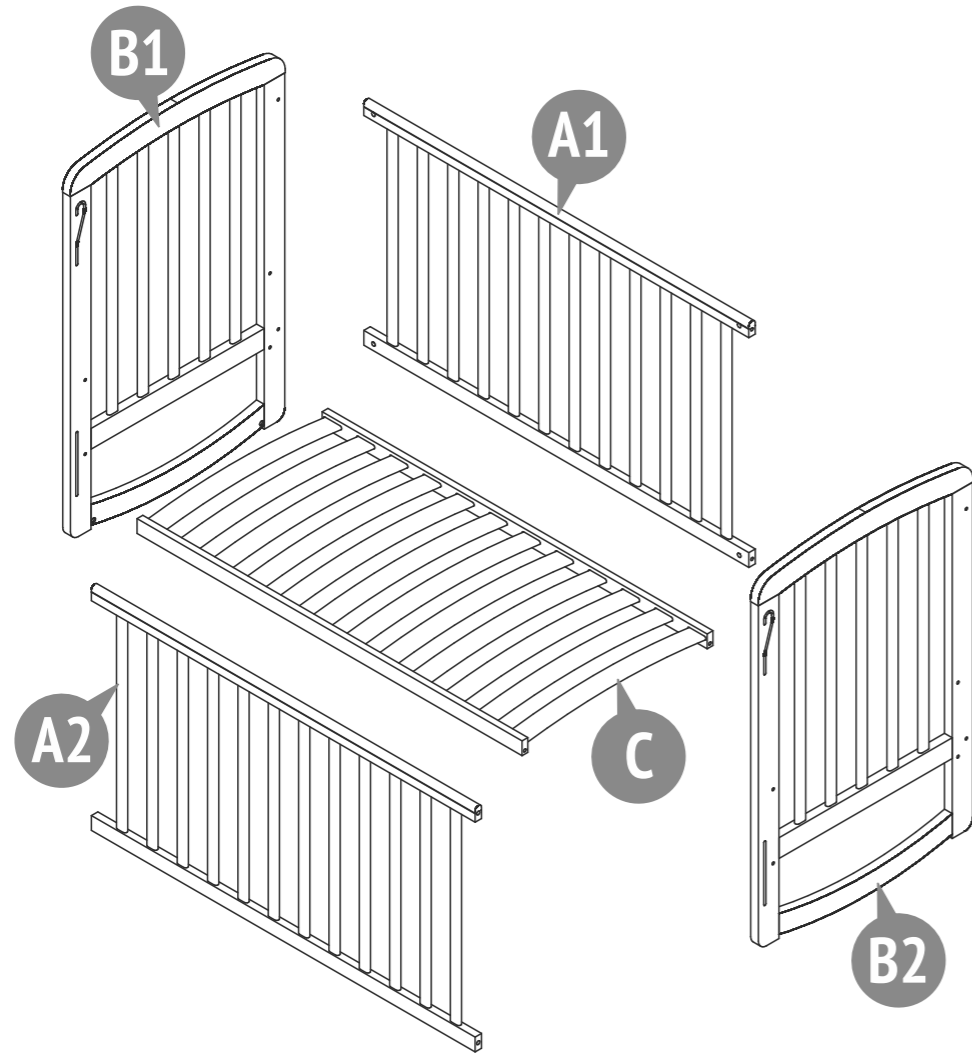

Number on the picture Nummer in der Zeichnung Nummer op figur Nombre à la figure Numero en el dibujo Il numero alla figura Número na figura Номер на рисунке الرقم على الرسمة	Number of parts in the product Stückzahl der Teile im Produkt Aantal componenten in het product Nombre des détails du produit Cantidad de elementos del producto La quantità dei dettagli nel prodotto Quantidade de peças Количество деталей в изделии كمية الأجزاء بالمنتج	Parts description Bezeichnung Onderdelen namen Names des pièces	Nombre de los elementos La nominazione dei dettagli Designação das peças Наименование деталей تسمية الأجزاء	Laying Verpackung Packing Pose	El embalaje Posa Estilo Укладка	ترتيب	Box / Karton / Plaats / Placer / المكان Lugar / Il posto / Espaço / Место
							1
A1	1	Cot bed's side Seitenschutz De achterkant van het kinderbedje Butées latérales	La guía lateral Barriere da fianco Barra de segurança Боковое ограждение	جانب السرير			●
A2	1	Cot bed's side Seitenschutz De achterkant van het kinderbedje Butées latérales	La guía lateral Barriere da fianco Barra de segurança Боковое ограждение	جانب السرير			●
B1	1	Cot's back Kopfteil Hoofdbord Tête du lit	El cabecero La spalliera del letto Cabeceira de cama Спинка кровати	مسند سرير			●
B2	1	Cot's back Kopfteil Hoofdbord Tête du lit	El cabecero La spalliera del letto Cabeceira de cama Спинка кровати	مسند سرير			●
C	1	Cot bed's bottom Lattenrost De onderkant van het kinderbedje Fond du lit	El fondo de la cuna Il fondo del letto Estrado de cama Дно кровати	قاع السرير			●
	1	Set of fittings Satz Beschläge Hang-en-sluitwerk Kit d'accessoires	Conjunto de los accesorios Il completo della fornitura Kit de ferragens Комплект фурнитуры	حزمة العدة			●

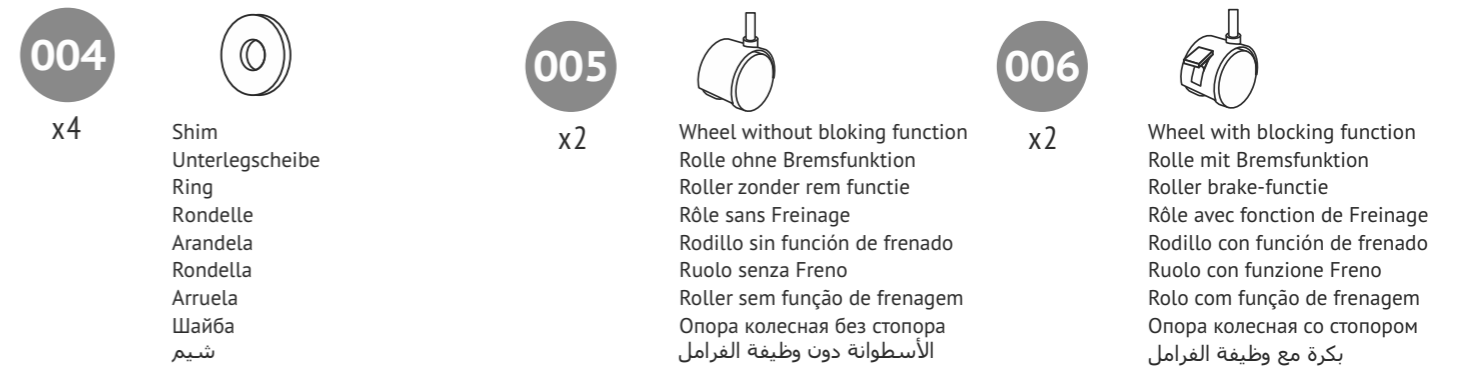
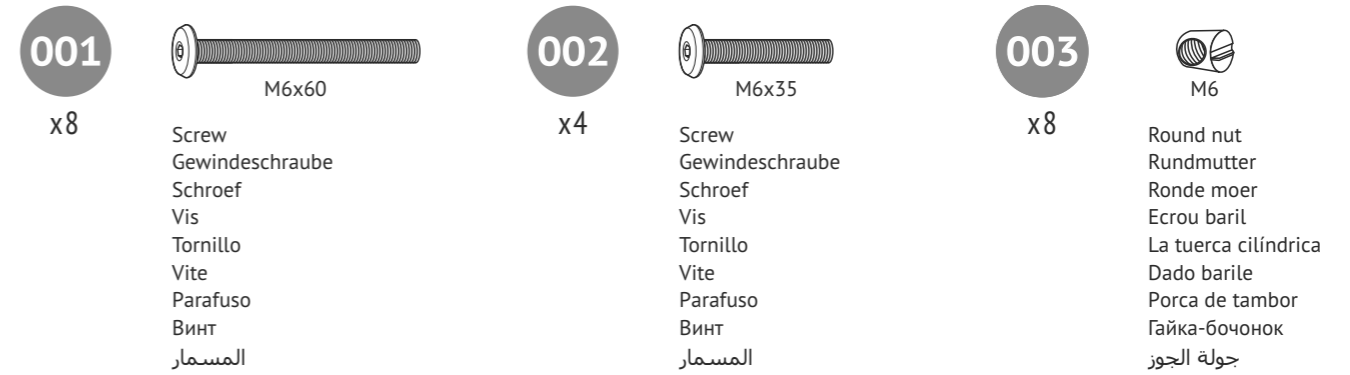

1

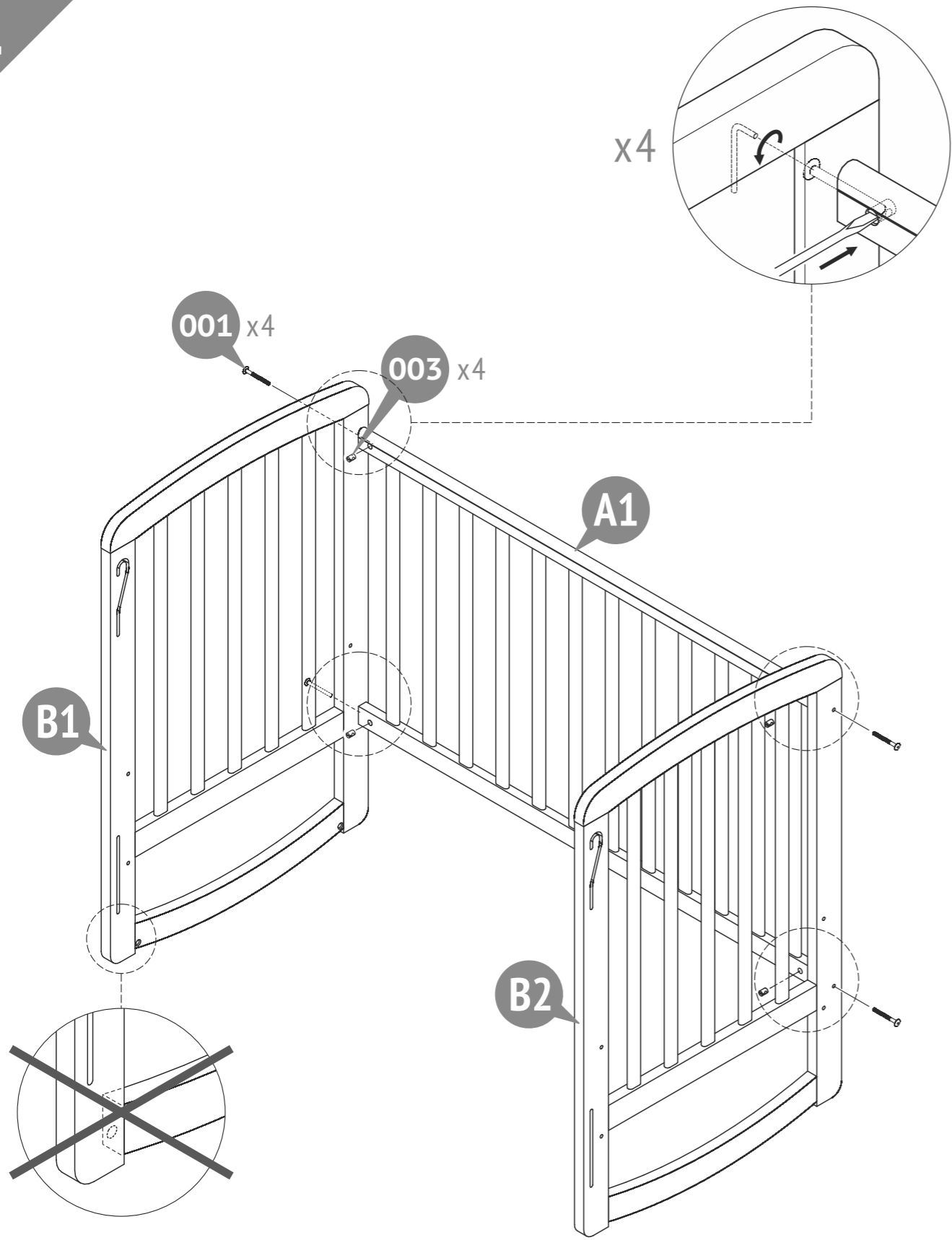

2

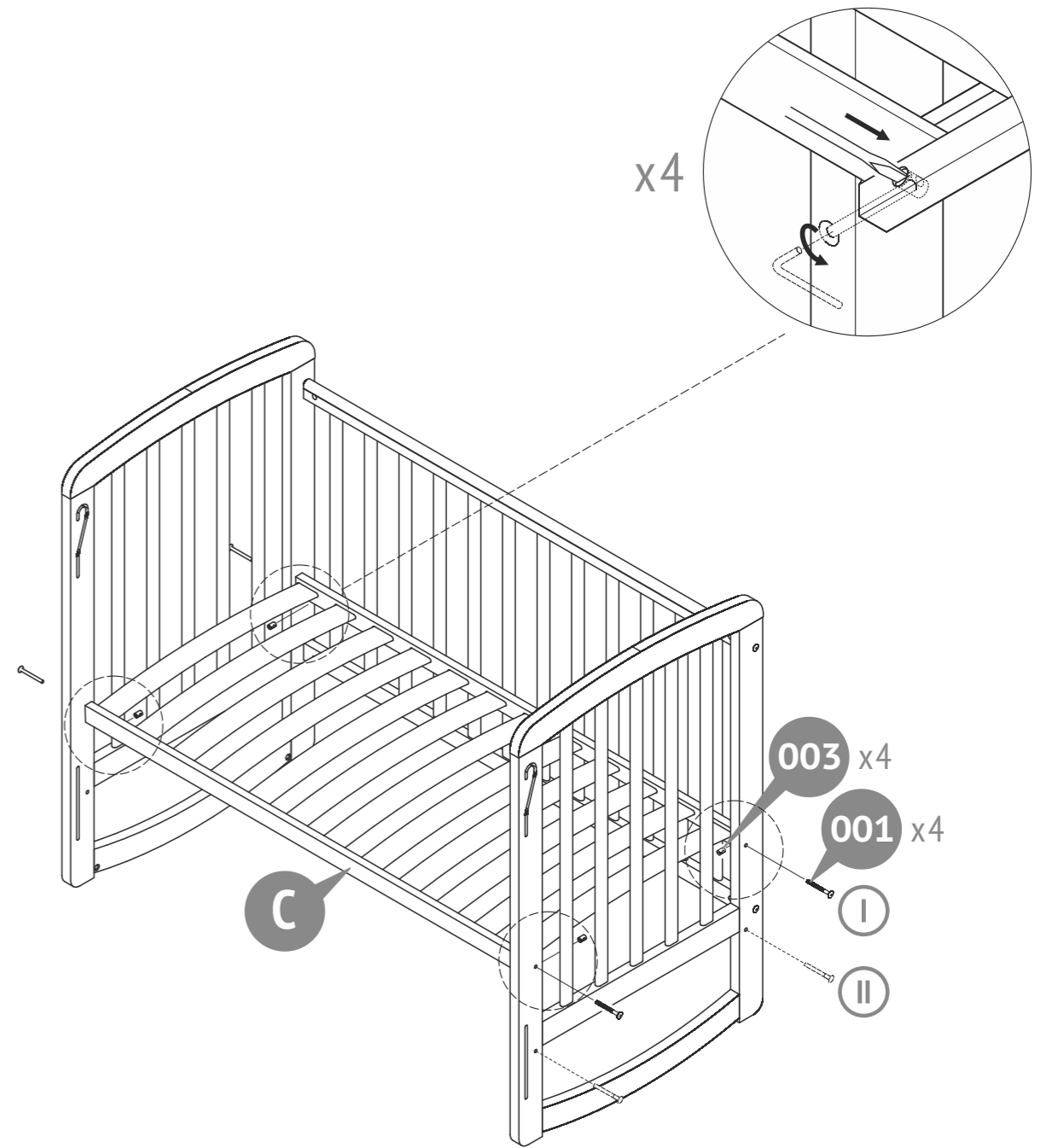

0-6M

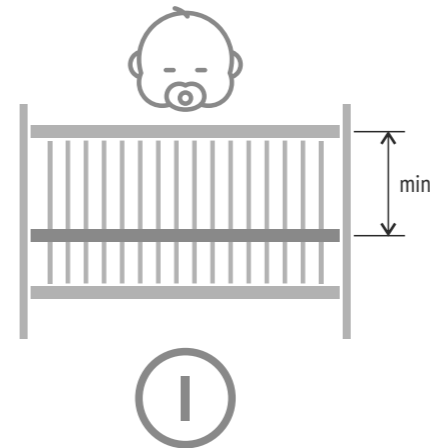

6M+

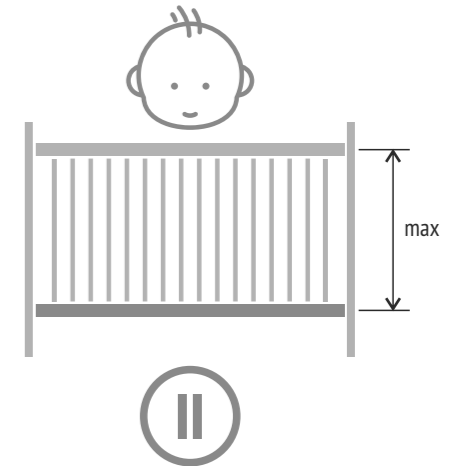

3

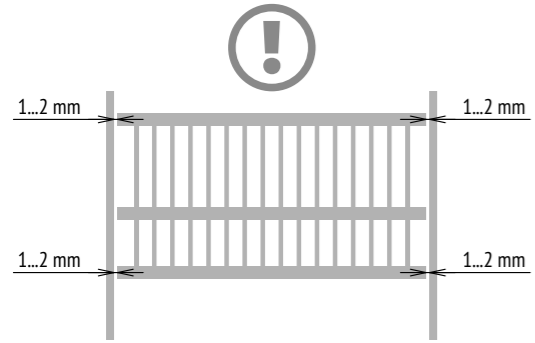
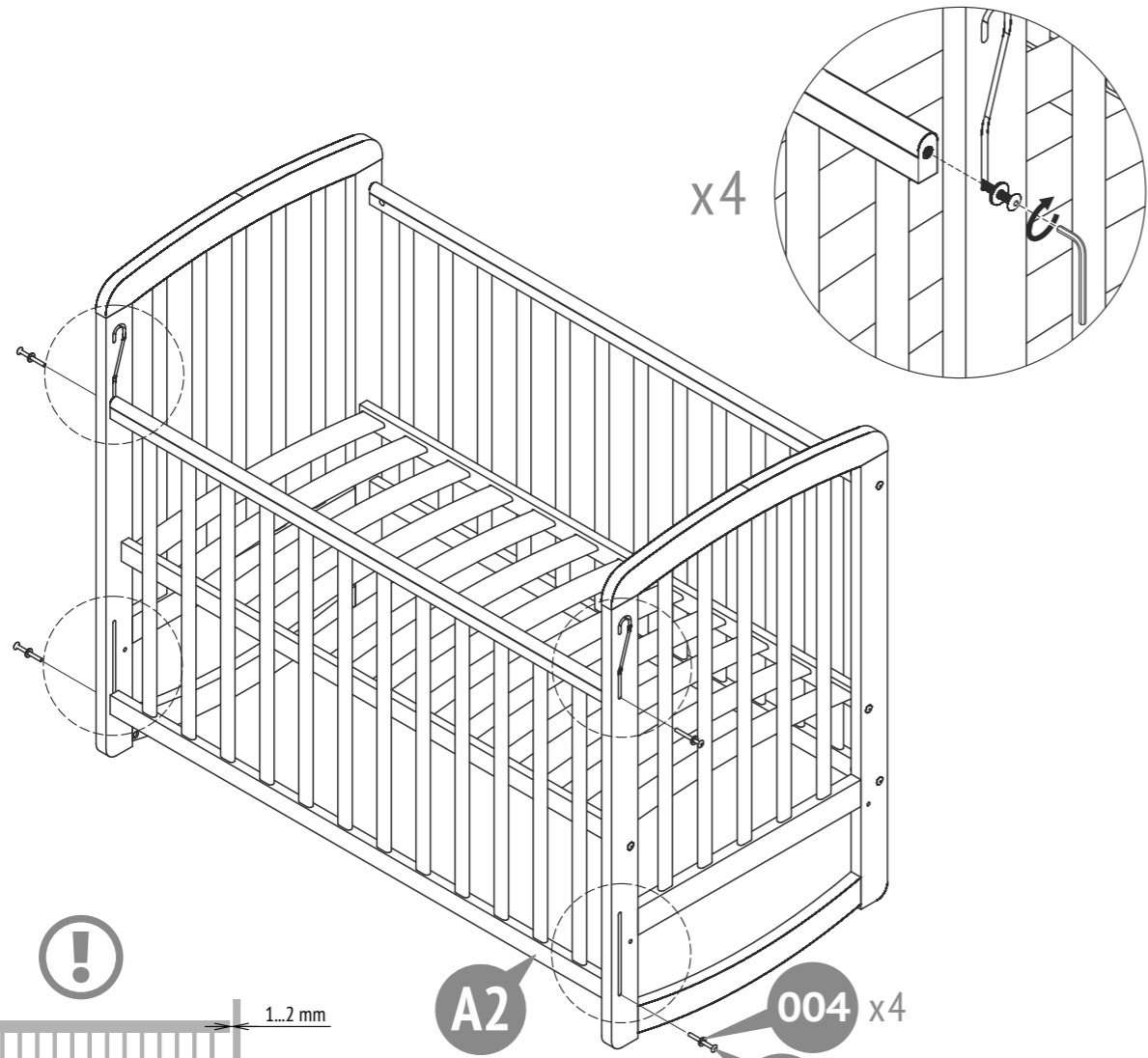

A2
004 x4
002 x4



I



II

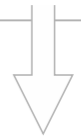

4

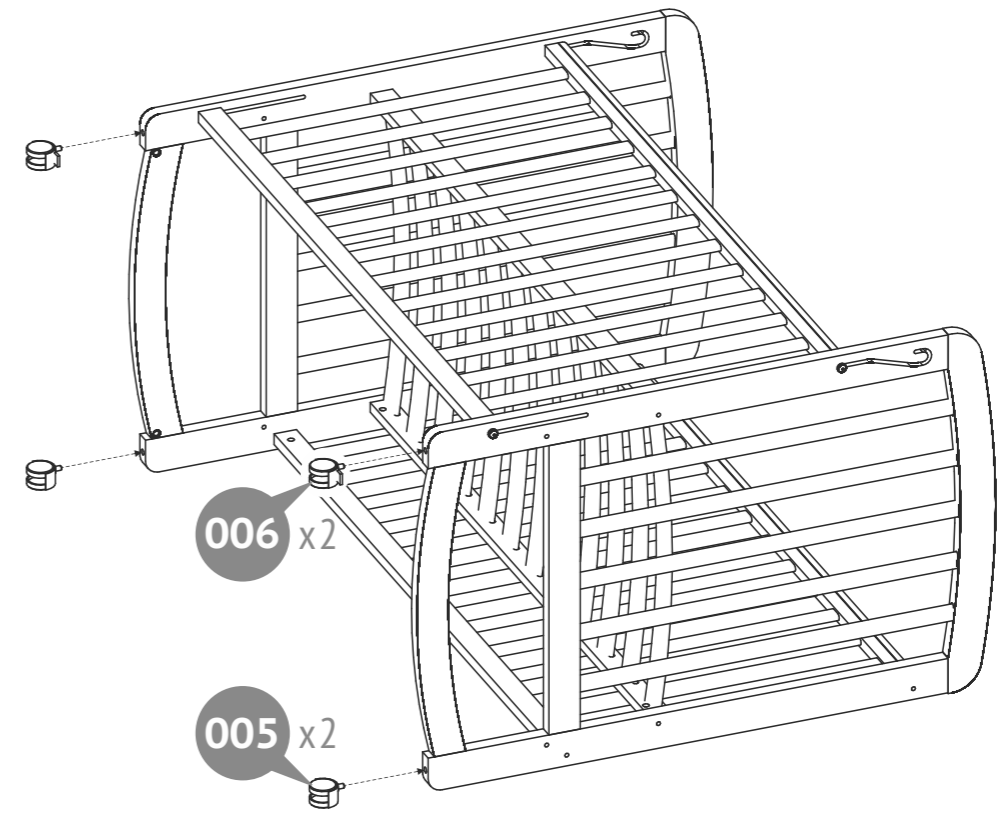



EN Minimum mattress size - 1140 x 540 mm.
Maximum thickness - 150 mm.
Do not use more than one mattress in cot.

DE Die Mindestgröße der Matratze - 1140 x 540 mm.
Die Maximale Höhe der Matratze - 150 mm.
Nie mehr als eine Matratze im Kinderbett benutzen.

NL Minimum matrasmaat - 1140 x 540 mm.
Maximale dikte - 150 mm.
Gebruik niet meer dan een matras in de babybedje.

FR La taille minimale du matelas - 1140 x 540 mm.
L'épaisseur maximale du matelas - 150 mm.
Ne pas utiliser plus d'un matelas dans le lit.

ES El tamaño mínimo del colchón - 1140 x 540 mm.
El espesor máximo - 150 mm.
No utilice más de un colchón en la cuna.

IT La misura minimale del materasso - 1140 x 540 mm.
Lo spessore massimale - 150 mm.
Non usate piu' di un materasso nel lettino.

P Tamanho mínimo do colchão - 1140 x 540 mm.
Espessura máxima - 150 mm.
Não utilize mais do que um colchão na cama.

RU Минимальный размер матраца - 1140 x 540 mm.
Максимальная толщина - 150 mm.
Не используйте более одного матраца в кроватке.

AE الحد الأدنى لحجم المراتب - ١١٤٠ دولار ٥٤٠ ملم.
أقصى سمك - ١٥٠ ملم.
لا تستخدم أكثر من واحد في فراش المهد