

5061 дз дуб апрель темный Модуль прихожей
5061 дз ясень анкор светлый Модуль прихожей

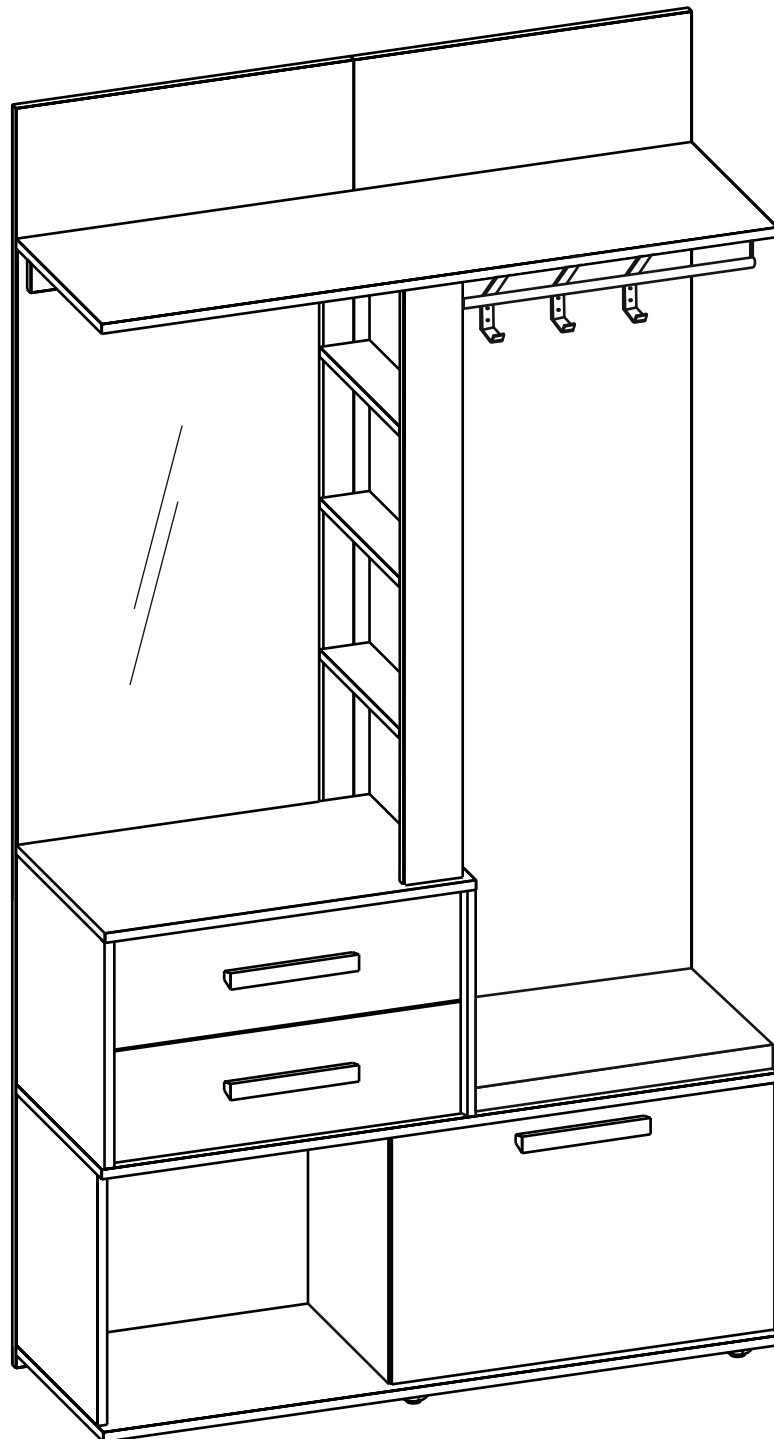

ИНСТРУКЦИЯ ПО СБОРКЕ

Русский

ВНИМАНИЕ!

Важная информация. Внимательно изучите её перед эксплуатацией изделия.

- Используйте изделие только по прямому назначению.
- Сборку изделия производите только в полном соответствии с прилагаемой инструкцией.
- Изделие может опрокинуться и нанести тяжёлые телесные повреждения. Прикрепите его к стене. Для крепления к стене используйте крепёж, подходящий для материала стен Вашего дома. Если Вы не уверены какой тип крепления подходит для материала стен, обратитесь к специалисту или в специализированный магазин.
- При эксплуатации дверей и выдвижных ящиков не прилагайте чрезмерных усилий.
- Рекомендуется ремонт механизмов трансформации доверить квалифицированным специалистам.
- Будьте осторожны при обращении с деталями из стекла. Избегайте ударных нагрузок. Из-за поврежденных краев и царапин на поверхности, стекло может внезапно треснуть и (или) разбиться.

English

ATTENTION!

Important information. Read it carefully before using the product.

- Use the product for its intended purpose only.
- Assemble the product only in full accordance with the attached instructions.
- The product may tip over and cause serious bodily injury. Attach it to the wall. In order to attach it to the wall, use fasteners suitable for the walling material at home. Should you be in doubt about the type of fasteners suitable for the walling material, contact a specialist or a specialized store.
- Do not apply excessive force, when using doors and drawers.
- It is recommended to entrust the repair of transformation mechanisms to qualified professionals.
- Be careful, when handling glass parts. Avoid shock loads. Due to the damaged edges and scratches on the surface, the glass may suddenly crack and (or) break.

Deutsch

ACHTUNG!

Wichtige Informationen. Lesen Sie sie sorgfältig durch, bevor Sie das Produkt verwenden.

- Verwenden Sie das Produkt nur für den vorgesehenen Anwendungszweck.
- Montieren Sie das Produkt nur unter Beachtung der beiliegenden Anleitung.
- Das Produkt kann umkippen und schwere Verletzungen verursachen. Befestigen Sie es an der Wand. Verwenden Sie zur Befestigung an der Wand eine für das Wandmaterial Ihres Hauses geeignete Wandhalterung. Wenn Sie sich nicht sicher sind, welche Art der Befestigung für Wandmaterial geeignet ist, wenden Sie sich an einen Spezialisten oder einen Fachhändler.
- Legen Sie beim Betrieb von Türen und Schubladen keine übermäßige Kraft an.
- Es wird empfohlen, die Umwandlungsmechanismen von Fachleuten reparieren zu lassen.
- Seien Sie vorsichtig beim Umgang mit Glasteilen. Vermeiden Sie die Stoßbelastungen. Beschädigte Kanten und Kratzer auf der Oberfläche können dazu führen, dass das Glas plötzlich splittert und/oder zerbricht.

Français

ATTENTION !

Informations importantes. Examinez-les attentivement avant d'utiliser l'article.

- Utilisez l'article uniquement aux fins prévues.
- Assemblez l'article uniquement conformément aux instructions fournies.
- Le produit peut se renverser en provoquant des blessures graves. Fixez-le au mur. Pour la fixation au mur, utilisez des attaches adaptées au matériau mural de votre maison. Si vous n'êtes pas sûr du type d'attaches appropriées pour le matériau mural, contactez un spécialiste ou un magasin spécialisé.
- Lorsque vous utilisez des portes et des tiroirs, ne faites pas d'efforts excessifs.
- Il est recommandé de confier la réparation des mécanismes de transformation à des spécialistes qualifiés.
- Faites attention lorsque vous manipulez des pièces en verre. Évitez les charges de choc. En raison des bords endommagés et des rayures sur la surface le verre peut se fissurer et / ou se briser soudainement.

Italiano

ATTENZIONE!

Informazioni importanti. Leggere attentamente prima di utilizzare il prodotto.

- Utilizzare il prodotto esclusivamente per i fini previsti dal produttore.
- Eseguire l'assemblaggio del prodotto solo in piena conformità al manuale allegato.
- Il prodotto potrebbe capovolgersi e causare gravi lesioni. Fissare il mobile al muro Per fissare il mobile al muro, utilizzare degli elementi di fissaggio adatti al materiale dei muri della casa. In caso di dubbi nel scegliere gli elementi di fissaggio adatti per il materiale dei muri, rivolgeti a uno specialista oppure a un negozio specializzato.
- Utilizzando le ante e i cassetti, non esercitare sollecitazioni eccessive.
- A dare la riparazione dei meccanismi di trasformazione solo a personale qualificato.
- Prestare la dovuta attenzione quando si maneggiano le parti in vetro. Evitare gli urti. In caso di estremità danneggiate o graffiate il vetro può rompersi improvvisamente e/o formare crepe.

Español

¡ATENCIÓN!

Información importante. Estúdiela con atención antes de usar el artículo.

- Emplee el artículo sólo para el uso previsto.
- Ensamble el artículo sólo de acuerdo con las instrucciones adjuntas.
- El artículo puede volcarse y causar lesiones graves. Fíjelo a la pared. Para fijarlo a la pared use los soportes adecuados para el material de las paredes de su casa. Si no está seguro de qué tipo de fijación es adecuada para el material de sus paredes, consulte a un especialista o a una tienda especializada.
- Al usar puertas y cajones, no aplique esfuerzos excesivos.
- Se recomienda que la reparación de los mecanismos de transformación se realice por especialistas calificados.
- Tenga cuidado al manipular piezas de vidrio. Evite las cargas de choque. A causa de los bordes dañados y arañazos en la superficie, el vidrio puede agrietarse repentinamente y (o) romperse.

Português

ATENÇÃO!

Informações importantes. Leia atentamente antes de utilizar o produto.

- Utilize o produto apenas para os fins pretendidos.
- A montagem do produto realiza-se exclusivamente de acordo com esse manual de instruções.
- O produto pode tombar e causar graves danos corporais. Prenda-o à parede. Para fixação na parede, utilize fixadores apropriados para o material das paredes da sua casa. Se você não tiver certeza de que tipo de suporte seja adequado para o material de parede, consulte um perito ou uma loja especializada.
- Quando usar as portas e gavetas, não aplique uma força excessiva.
- Recomendamos confiar a reparação de mecanismos de transformação aos profissionais qualificados.
- Tenha cuidado ao manusear peças de vidro. Evite impactos. Devido as bordas danificadas e arranhões na superfície, o vidro, de repente, pode rachar-se ou quebrar.

Türkçe

DİKKAT!

Önemli bilgiler. Ürünü kullanmadan önce dikkatlice inceleyiniz.

- Ürünü yalnızca amacına uygun bir şekilde kullanın.
- Ürünün montajı sadece ekteki talimatlara tam uygun olarak yapılmalıdır.
- Ürün devrilebilir ve ciddi yaralanmalara neden olabilir. Bundan dolayı duvara tutturun. Bir duvara sabitlemek için, eviniz duvarlarının malzemesine uygun bağlantı elemanları kullanın. Duvar malzemesi için hangi bağlantı tipinin uygun olduğundan emin değilseniz, bir uzmana veya ihtisaslı mağazaya danışın.
- Kapı ve çekmeceleri kullandığınız zaman aşırı güç kullanmayın.
- Dönüşüm mekanizmalarının onarımının kalifiye uzmanlara bırakılması tavsiye edilir.
- Cam parçalarını kullanırken dikkatli olun. Darbe yüklerinden kaçının. Zarar görmüş kenarlar ve yüzeydeki çizikler nedeniyle cam aniden çatlayabilir ve / veya kırılabilir.

Беларускі

УВАГА!

Важная інфармацыя. Уважліва вывучыце яе перад эксплуатацыяй вырабу.

- Выкарыстоўвайце выраб толькі па прамым прызначэнні.
- Збірайце выраб толькі ў адпаведнасці з прыкладзенай інструкцыяй.
- Выраб можа перакуліцца і нанесці цяжкія цялесныя пашкоджанні. Прымацуйце яго да сцяны. Для мацавання да сцяны выкарыстайце крапеж, які падыходзіць да матэрыялу сценаў вашага дому. Калі вы не ўпэўнены, які тып мацавання падыходзіць да матэрыялу сценаў, звярніцеся да спецыяліста або ў спецыялізаваную краму.
- Пры эксплуатацыі дзвярэй і высоўных шуфляд не прыкладайце празмерных намаганняў.
- Рамонт механізмаў трансфармацыі рэкамендуецца даручыць кваліфікаваным спецыялістам.
- Будзьце асцярожныя пры абыходжанні з дэталямі са шкла. Пазбягайце ўдарных нагрузак. З-за пашкоджаных бакоў і драпін на паверхні шкла можа раптам трэснуць і (або) разбіцца.

Қазақ

НАЗАР АУДАРЫҢЫЗ!

Маңызды ақпарат. Оны бұйымды пайдаланбас бұрын мұқият оқып шығыңыз.

- Бұйымды тек тікелей тағайындалуы бойынша пайдаланыңыз.
- Бұйымды құрастыруды қоса берілген нұсқаулыққа толық сәйкес жүргізіңіз.
- Бұйымның аударылып кетуі және ауыр дене жарақаттарын туғызуы мүмкін. Оны қабырғаға бекітіңіз. Қабырғаға бекіту үшін өз үйіңіздің материалына сәйкес келетін бекітпені пайдаланыңыз. Егер қабырға материалы үшін бекіткіштің қандай түрі сәйкес келетініне сенімді болмасаңыз, маманға немесе мамандандырылған дүкенге жүгініңіз.
- Есіктерді және жылжымалы жөшіктерді пайдалану кезінде шамадан тыс күш салмаңыз.
- Трансформация механизмдерін жөндеуді білікті мамандарға сеніп тапсыру ұсынылады.
- Шыныдан жасалған бөлшектермен жұмыс істеу кезінде сақ болыңыз. Соққы жүктемелерінен аулақ болыңыз. Зақымдалған шеттері мен үстіңгі бетінің сызаттарынан шынының кенеттен шытынауы және (немесе) сынып кетуі мүмкін.

Кыргыз

КӨҢҮЛ БУРУҢУЗДАР!

Маанилүү маалымат. Буюмду пайдалануунун алдында аны кунт коюп окуп чыгыңыз.

- Буюмду анын тике арналышы боюнча гана пайдаланыңыз.
- Буюмду тиркелген нускамага толук шайкештикте гана чогултуңуз.
- Буюм оодарылып кетип, денеге катуу жарақаттарды келтириши мүмкүн. Аны дубалга бекитиңиз. Эмеректи дубалга бекитүү үчүн, Сиздин үйүңүздүн дубалдарынын материалына туура келген бекиткичти колдонуңуз. Эгерде Сиз дубалдардын материалына бекиткичтин кайсы түрү туура келишин билбесеңиз, адиске же адистештирилген дүкөнгө кайрылыңыз.
- Эшиктерди жана суурма жашыктарды пайдаланууда ашыкча күч-аракет жумшабаңыз.
- Трансформациялоо механизмдерин оңдоону квалификациялуу адистерге ишенүүнү сунуш кылабыз.
- Айнектен жасалган бөлүктөрүн колдонууда сак болуңуз. Буюмду урунуудан сактаңыз. Четтериндеги майда сыныктардан жана бетиндеги чийиктерден улам, айнек кокусунан жарака кетиши жана (же) сынып калышы мүмкүн.

O'zbek

DIQQAT!

Muhim ma'lumotlar. Mahsulotni ishlatishdan oldin uni diqqat bilan o'rganib chiqing.

- Mahsulotdan faqat maqsadiga muvofiq foydalaning.
- Mahsulotni ilova qilingan ko'rsatmalarga to'liq muvofiq holda yig'ing.
- Mahsulot yiqilib ketishi va jiddiy tan jarohatlarini yetkazishi mumkin. Uni devorga mahkamlang. Devorga mahkamlash uchun uyingiz devorlarining materialiga mos mahkamlagichlardan foydalaning. Agar devor materiali uchun qanday mahkamlagichlar mos kelishiga ishonchingiz komil bo'lmasa, mutaxassis yoki ixtisoslashtirilgan do'konga murojaat qiling.
- Eshiklar va tortmalardan foydalanish chog'ida ortiqcha kuch ishlatmang.
- Transformatsiya mexanizmlarini ta'mirlashni malakali mutaxassislarga topshirish tavsiya etiladi.
- Shisha qismlardan foydalanganda ehtiyot bo'ling. Zarbali yuklardan saqlaning. Sirdagi shikastlangan qirralar va tiralishlar tufayli shisha to'satdan yorilishi va (yoki) sinib ketishi mumki.

Требования по эксплуатации изделия и меры предосторожности

Срок, в течение которого мебель сохраняет красоту и исправность, в значительной степени зависит от условий её хранения и эксплуатации. Придерживаясь некоторых простых практических советов, Вы сможете поддерживать в наилучшем состоянии все элементы Вашей мебели.

Свет

Не допускайте прямого воздействия солнечных лучей на мебель. Продолжительное прямое воздействие света на некоторые участки может вызвать изменение их цветовых характеристик по сравнению с другими участками, которые меньше подвергались воздействию.

Температура

Высокие значения тепла или холода, а также внезапные перепады температуры могут серьезно повредить мебель или её части. Мебель не должна располагаться ближе одного метра от источников тепла, нагревательных приборов. Рекомендуемая температура воздуха для хранения и эксплуатации от +10 до +25 °С. Не допускайте попадания на мебель горячих предметов (утюги, посуда с кипятком и пр.), а также продолжительного воздействия вызывающих нагревание излучений (свет мощных ламп, микроволновые излучатели и т. п.).

Влажность

Рекомендуемая относительная влажность местонахождения мебели 60-70%. Не следует поддерживать в течение продолжительного времени условия крайней влажности и (или) сухости, а тем более их периодической смены. С течением времени такие условия могут повлиять на целостность мебели и её части. Если такие условия были созданы, рекомендуется часто проветривать помещения и по мере возможности пользоваться осушителями или увлажнителями для нормализации влажности. Не размещайте мебель вблизи влажных и сырых стен, предметов.

Агрессивные среды и абразивные материалы

Ни в коем случае не допускайте воздействие на мебель агрессивных жидкостей (кислот, щелочей, растворителей и т.п.), содержащих такие жидкости продуктов и их паров. Подобные вещества и их соединения являются химически активными, реакция с ними может повлечь негативные последствия для Вас и Вашего имущества. Также стоит помнить, что некоторые специфические моющие (чистящие) составы (средства) могут содержать высокую концентрацию агрессивных химических веществ и (или) абразивные составы. Применение подобных моющих (чистящих) составов (средств) недопустимо.

Запах

От новой мебели может исходить естественный запах материалов, из которых она изготовлена. Запах может сохраняться в течении 3 недель с момента сборки. Для снижения интенсивности запаха рекомендуется:

- для мягкой мебели – пропылесосить изделие и проветрить помещение.
- для корпусной мебели – протирать тканью, смоченной мягким моющим средством, вытирать чистой сухой тканью и проветривать помещение, предварительно открывая все дверцы и ящики изделия.

Данные действия необходимо повторять 3-4 раза в день.

Уход за мебелью

Всегда содержите поверхности мебели в полной сухости. При необходимости, протирайте поверхности мебели сухой мягкой тканью (фланель, сукно, войлок и т.п.). Рекомендуется очищать мебель как можно скорее после того, как она испачкалась. Если Вы оставите загрязнение на некоторое время, то заметно повышается опасность образования разводов, пятен и повреждений покрытия мебели или её частей. В случае стойких загрязнений рекомендуется использовать специальные очистители. Внимательно изучайте инструкцию моющего средства: средство должно подходить под тип покрытия Вашей мебели. Недопустимо применение моющих средств, содержащих абразивные вещества. Недопустимо применение соды, стиральных порошков и прочих средств, не предназначенных для ухода за мебелью. Уход за поверхностями должен осуществляться специализированными моющими средствами.

Для устранения пыли с поверхностей мягких частей мебели используйте пылесос со специальными насадками для чистки мебели.

Не размещайте и не перемещайте на поверхностях мебели предметы, имеющие острые углы, кромки, выступающие острые детали.

Эксплуатация

Нагрузка на мебель и её части (полки, ящики, сидения и пр.) не должна превышать установленных производителем норм, указанных в конце инструкции по сборке.

Не рекомендуется вставать на мебель, прыгать, подвергать повышенным динамическим нагрузкам. Рекомендуется периодически проверять плотность резьбовых соединений крепления механизмов трансформации и подтягивать их при необходимости.

При появлении скрипов в механизмах трансформации их следует смазывать специализированной смазкой.

При использовании механизма трансформации строго соблюдайте данную инструкцию, избегайте излишних усилий, рывков, перекосов элементов механизма.

Operational Requirements and Safety Precautions for Furniture

A period, during which the furniture retains its appearance and serviceability, largely depends on how it is stored and operated. Follow simple tips to keep your furniture in the best condition.

Light

Do not expose your furniture to direct sunlight. Prolonged direct exposure to sunlight may result in colour changes in some areas, compared to the rest of the item that has been less exposed.

Temperature

Extreme temperatures, as well as sudden changes in temperature, can seriously damage the furniture or its parts. Do not place your furniture closer than one metre from heat sources and/or heating devices. The recommended ambient temperature for storage and operation is from +10 to +25 °C. Do not put hot objects (irons, dishes with boiling water, etc.) on your furniture, as well as do not expose it to heat radiation (light of powerful lamps, microwave emitters, etc.) over a long period of time.

Humidity

The recommended relative humidity for rooms with the furniture is 60-70%. Avoid long periods of extreme humidity and/or dryness, even more so avoid their periodic change. Over time, such conditions can affect the integrity of your furniture and its parts. If such conditions are observed, it is recommended to frequently ventilate the room and, if possible, use dehumidifiers/humidifiers to normalise the humidity level.

Do not place your furniture near damp or wet walls or objects.

Aggressive and abrasive products

Keep away aggressive liquids (acids, alkalis, solvents, etc.) or products containing such liquids and their vapours from your furniture. Such substances and their compounds are chemically active and interaction with them may lead to negative consequences for you and your property. Also, some detergents or cleaners contain high concentrations of aggressive chemicals and/or abrasive substances. The use of such detergents or cleaners is not allowed.

Smell

New furniture may have a natural smell of materials, which it is made from. The smell can linger for 3 weeks from the date of assembly. To reduce the intensity of such smell, it is recommended:

- for upholstered furniture, vacuum clean the item and ventilate the room.
- for cabinet furniture, wipe the item with a cloth soaked in a mild detergent, wipe with a clean dry cloth, and ventilate the room, pre-opening all doors and drawers of the furniture.

Repeat 3-4 times a day.

Maintenance

Always keep the surfaces of your furniture completely dry. If necessary, wipe the surfaces of your furniture with a dry soft cloth (flannel, cloth, felt, etc.). It is recommended to clean the furniture as soon as possible after it gets dirty. If not removed promptly, contamination may leave stains or damage the coating of the furniture or its parts. For persistent contamination, it is recommended to use special cleaners. Carefully read instructions how to use a detergent: the product shall be intended for materials, which furniture is made from. Do not use detergents containing abrasives. Do not use baking soda, washing powders, and other cleaners, not intended for furniture. Clean the surfaces of your furniture using special detergents.

To remove dust from soft parts of the furniture, use a vacuum cleaner with special nozzles for cleaning furniture.

Do not place or move objects with sharp corners, edges, and/or protruding sharp parts on the furniture.

Operation

The load on the furniture and its parts (shelves, drawers, seats, etc.) shall not exceed the manufacturer's standards, specified in the Assembly Guidelines.

It is not recommended to stand on the furniture, jump, or subject the furniture to high dynamic loads.

Periodically, check the tightness of threaded connections of fastening transformation mechanisms and tighten them, if necessary.

If transformation mechanisms begin to creak, lubricate them with a special lubricant.

When using transformation mechanisms, strictly follow these guidelines, avoid excessive efforts, jerks, and distortions of mechanism elements.



90-120 min

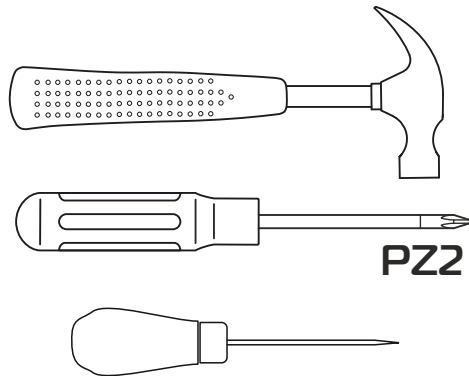
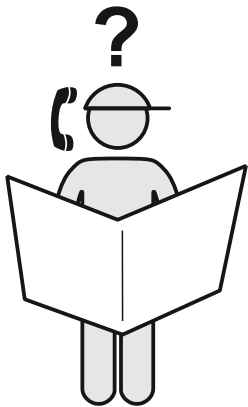
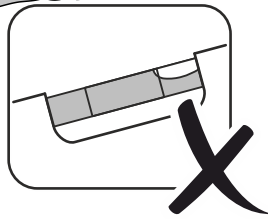
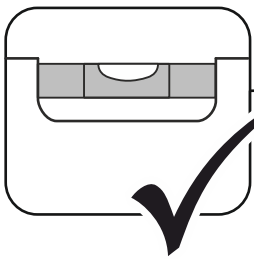
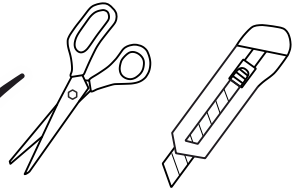
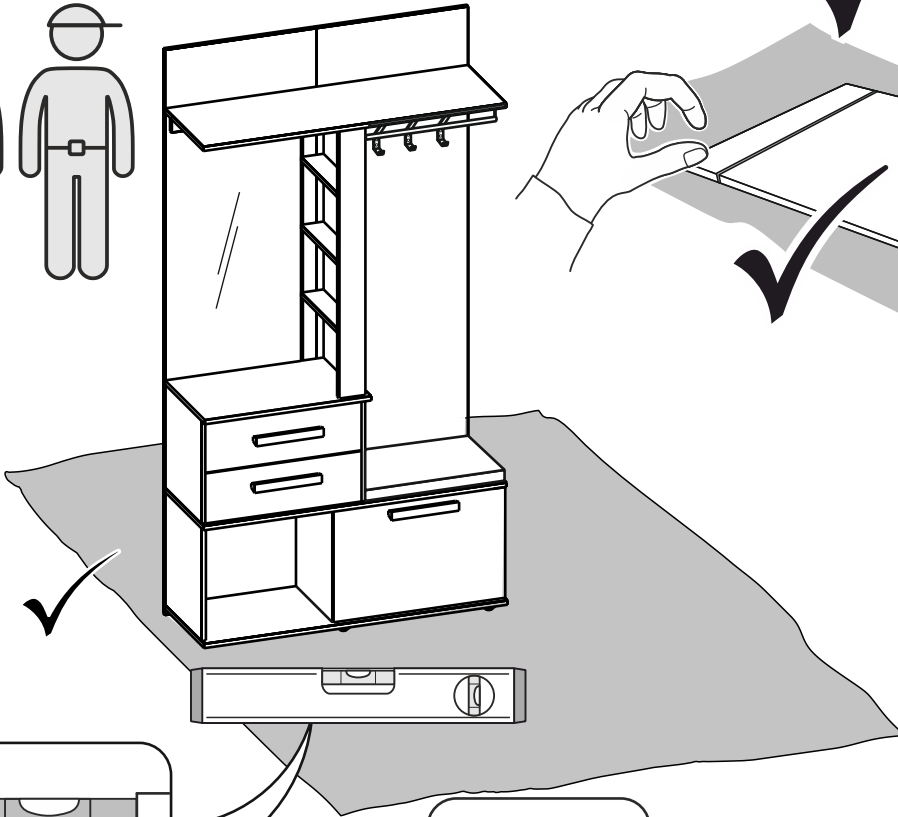
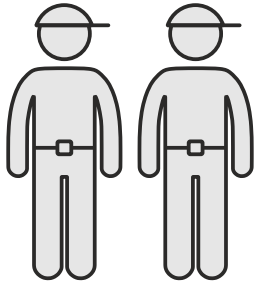

PZ2

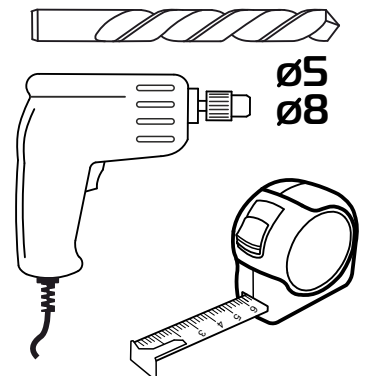

Ø5
Ø8

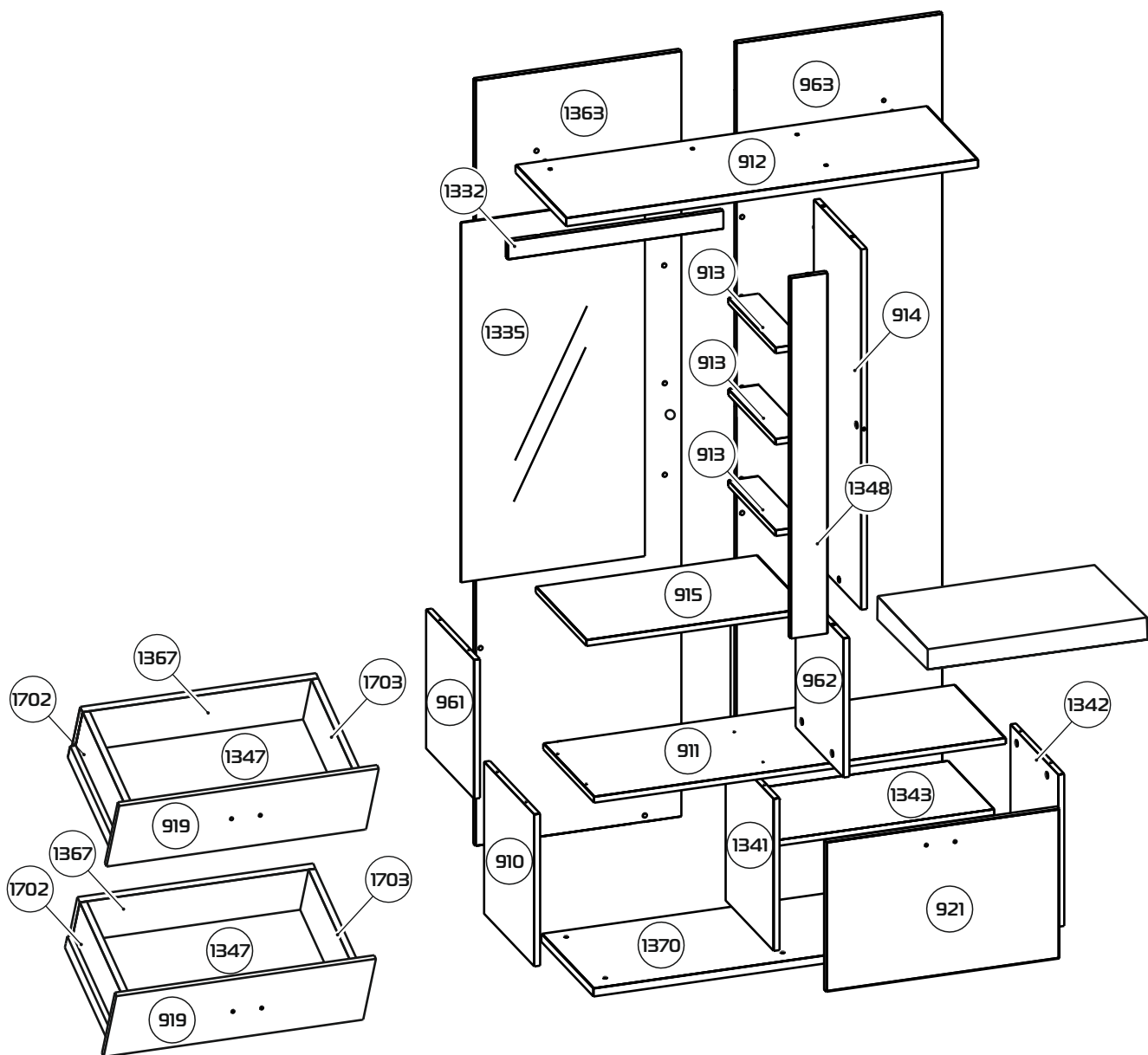

Деталь	№ детали	Габаритные размеры, мм	Количество	Упаковка
Дверь	921	634x415x16	1	№1
Стенка лицевая ящика	919	565x189x16	2	№1
Дно ящика	1347	528x322x16	2	№1
Зеркало	1335	996x500x4	1	№2
Стенка вертикальная	910	421x370x16	1	№3
Стенка горизонтальная	911	1120x375x16	1	№3
Стенка горизонтальная	912	1120x375x16	1	№3
Стенка горизонтальная	913	349x83x16	3	№3
Стенка вертикальная	914	998x349x16	1	№3
Стенка горизонтальная	915	603x375x16	1	№3
Стенка вертикальная	961	385x375x16	1	№3
Стенка вертикальная	962	385x375x16	1	№3
Стенка вертикальная	963	2108,5x560x16	1	№3
Планка	1332	586x50x16	1	№3

Деталь	№ детали	Габаритные размеры, мм	Количество	Упаковка
Стенка вертикальная	1341	421x354x16	1	№3
Стенка вертикальная	1342	421x354x4	1	№3
Полка	1343	600x340x16	1	№3
Планка	1348	998x100x16	1	№3
Стенка вертикальная	1363	2108,5x560x16	1	№3
Стенка задняя ящика	1367	544x125x16	1	№3
Стенка горизонтальная	1370	1120x384x16	1	№3
Стенка боковая ящика	1702	300x140x16	2	№3
Стенка боковая ящика	1703	300x140x16	2	№3
Фурнитура	-	-	-	№4
Инструкция по сборке	-	-	1	№4

1:1

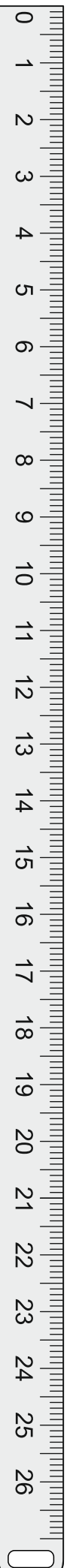
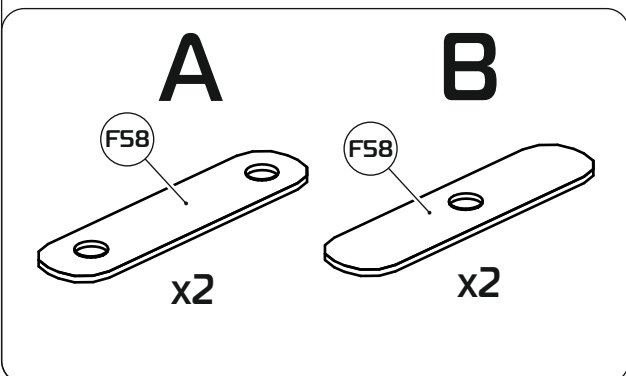
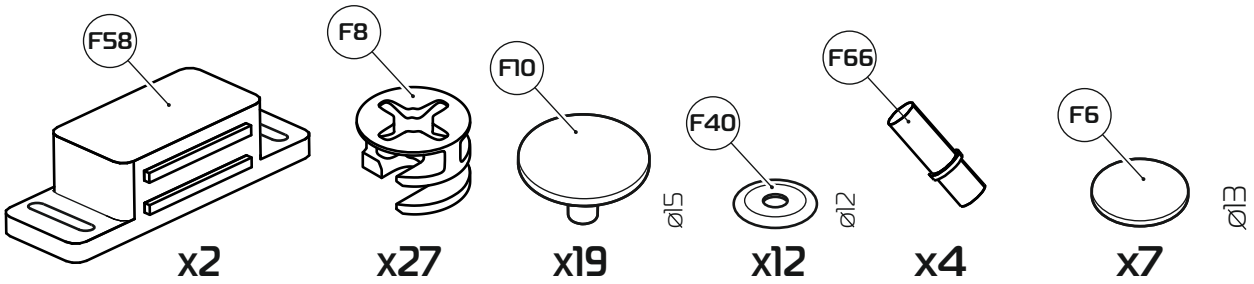
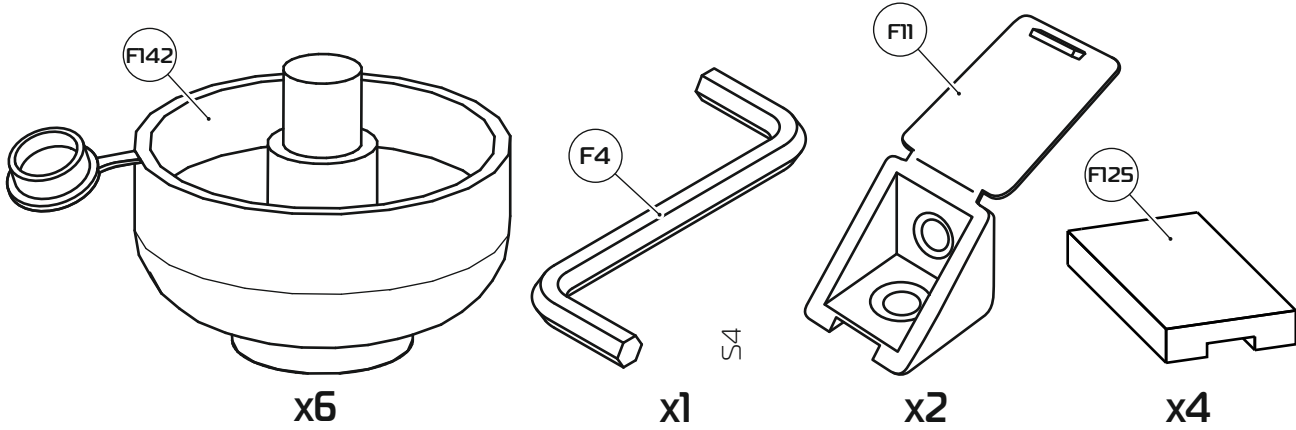
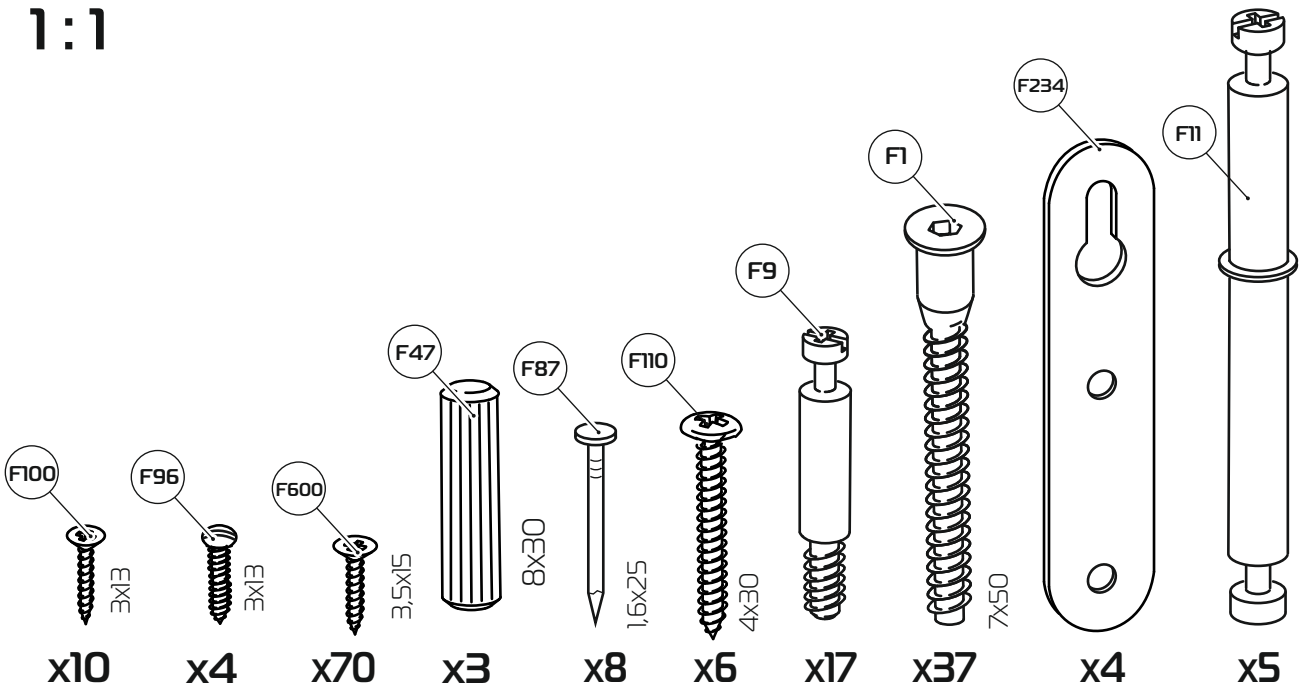

1:4

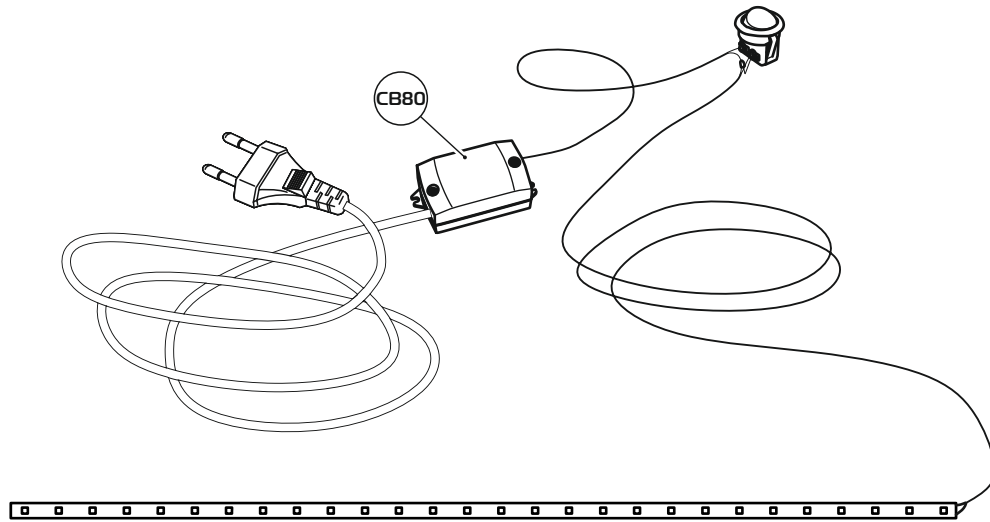

x1

1:1

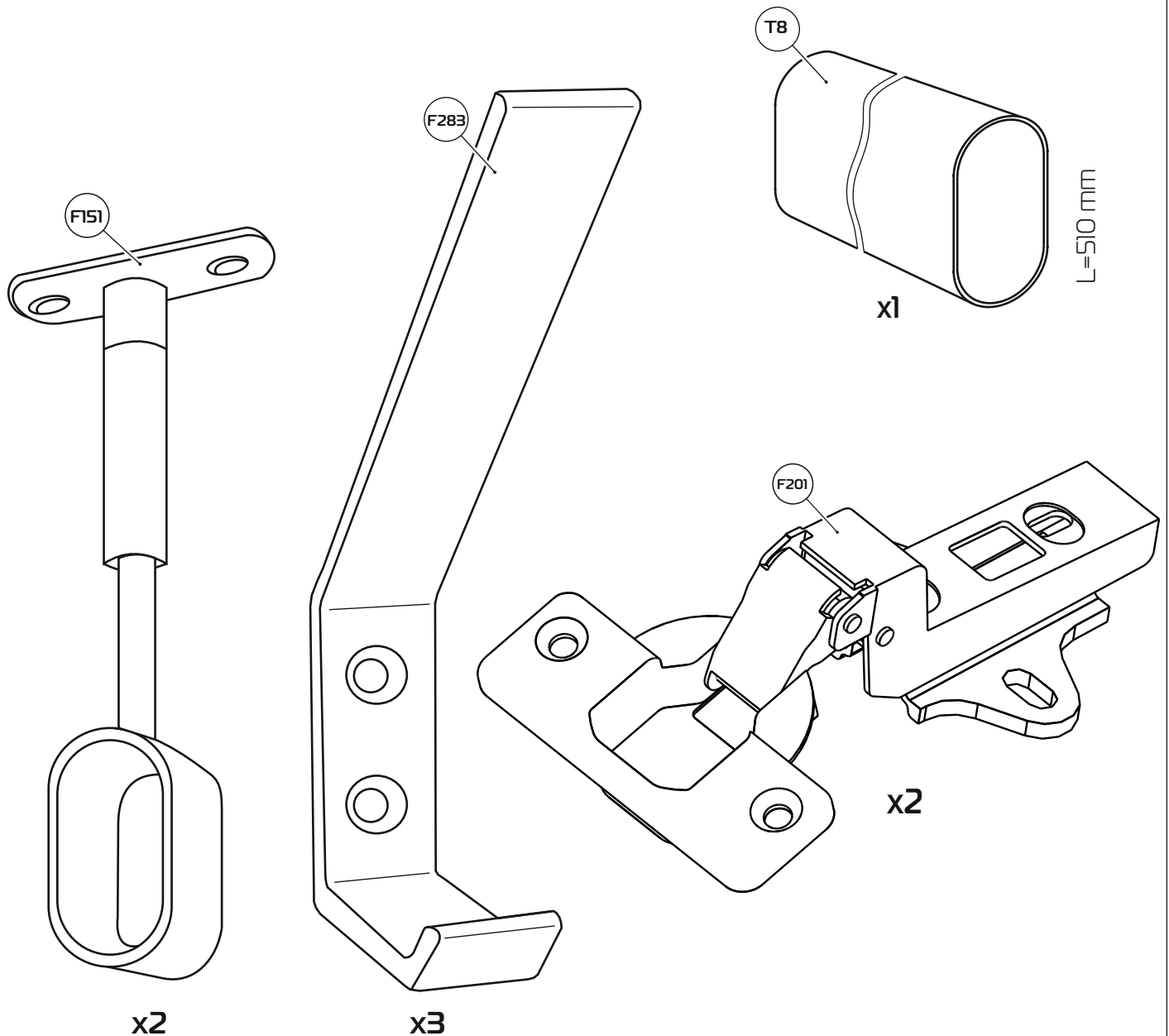

1:2

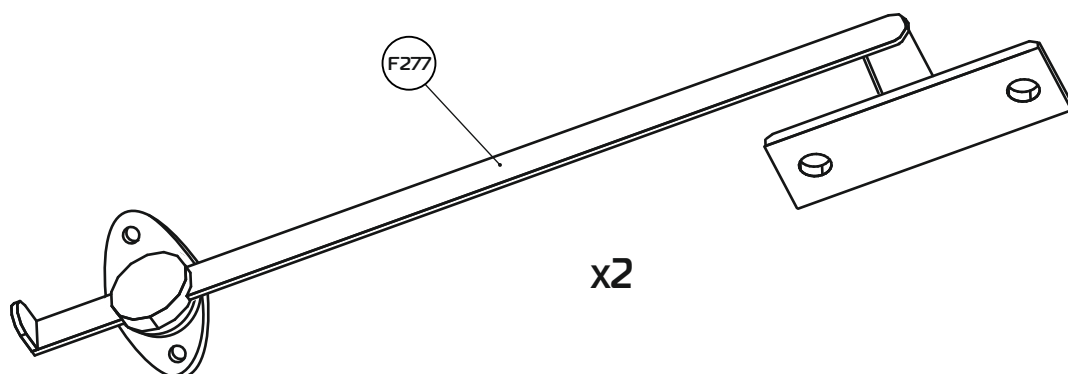
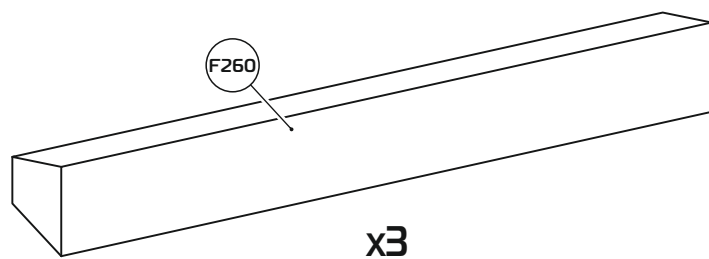
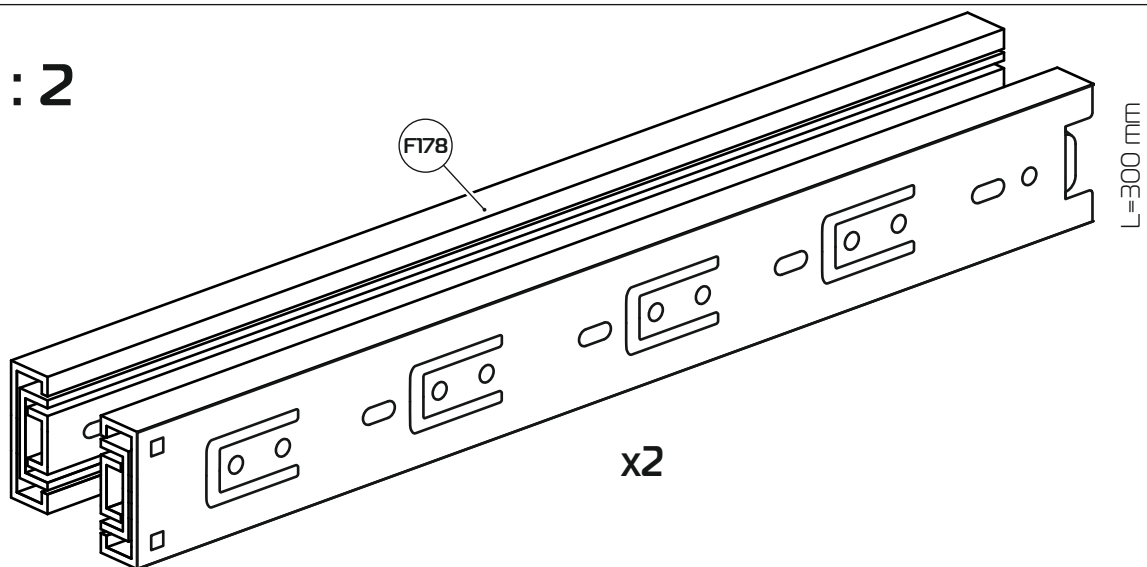

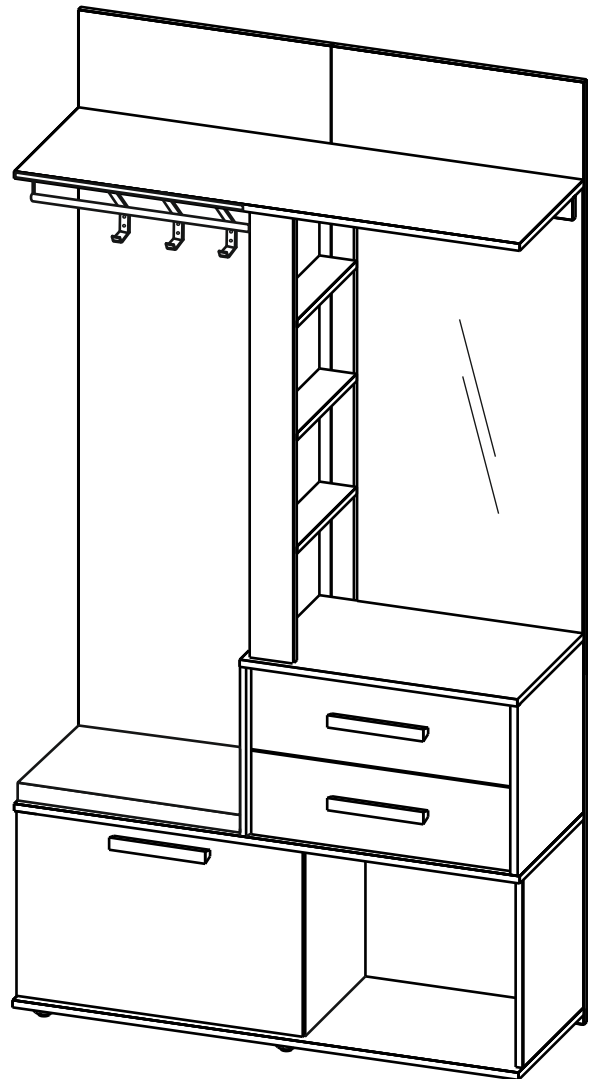
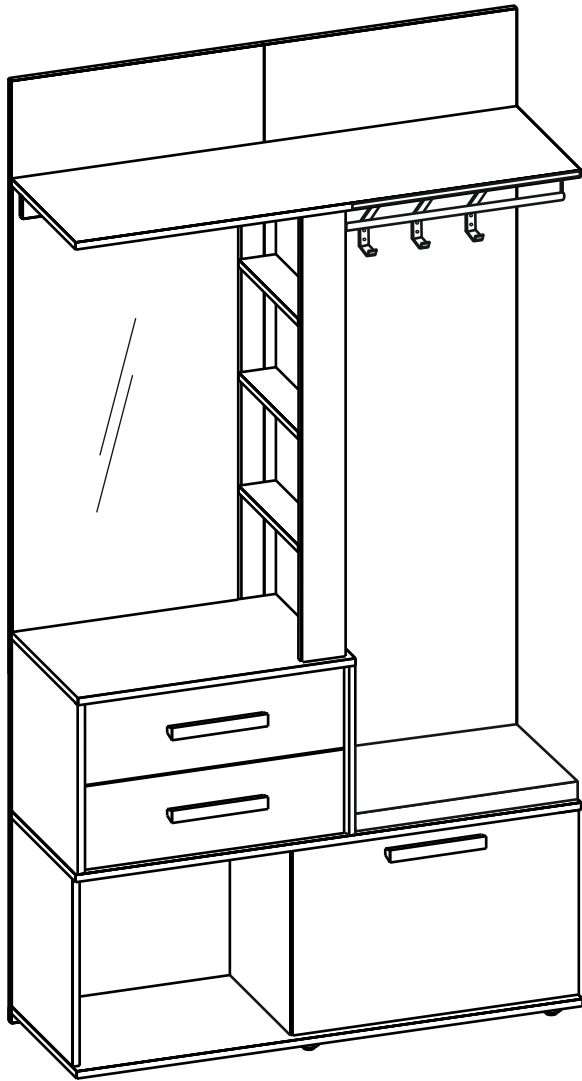

1

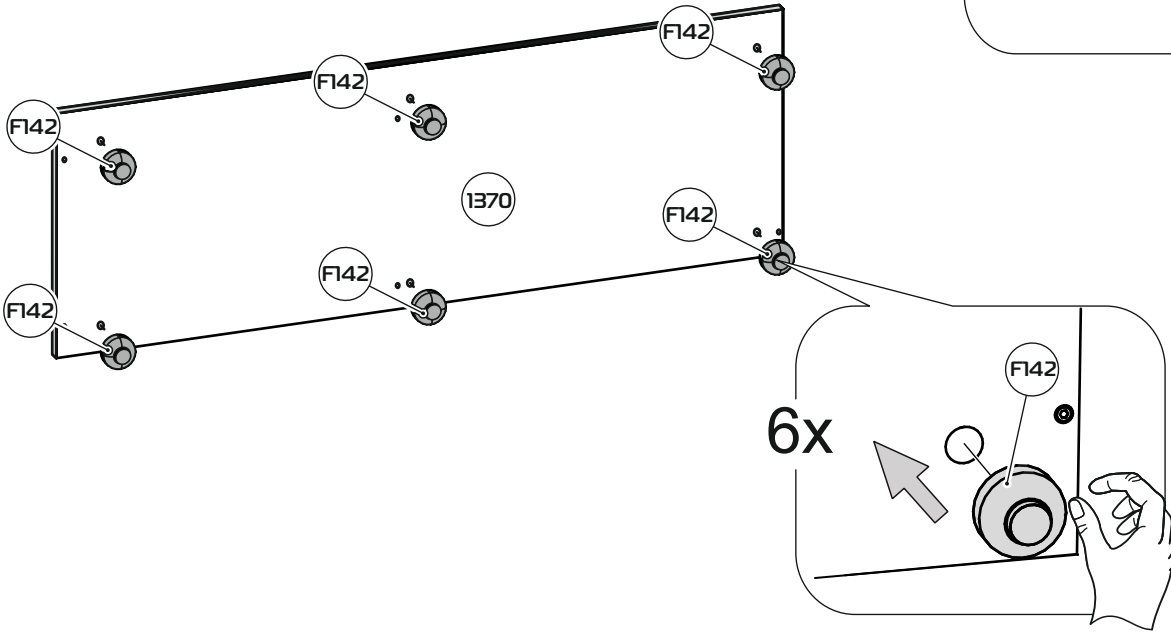

2

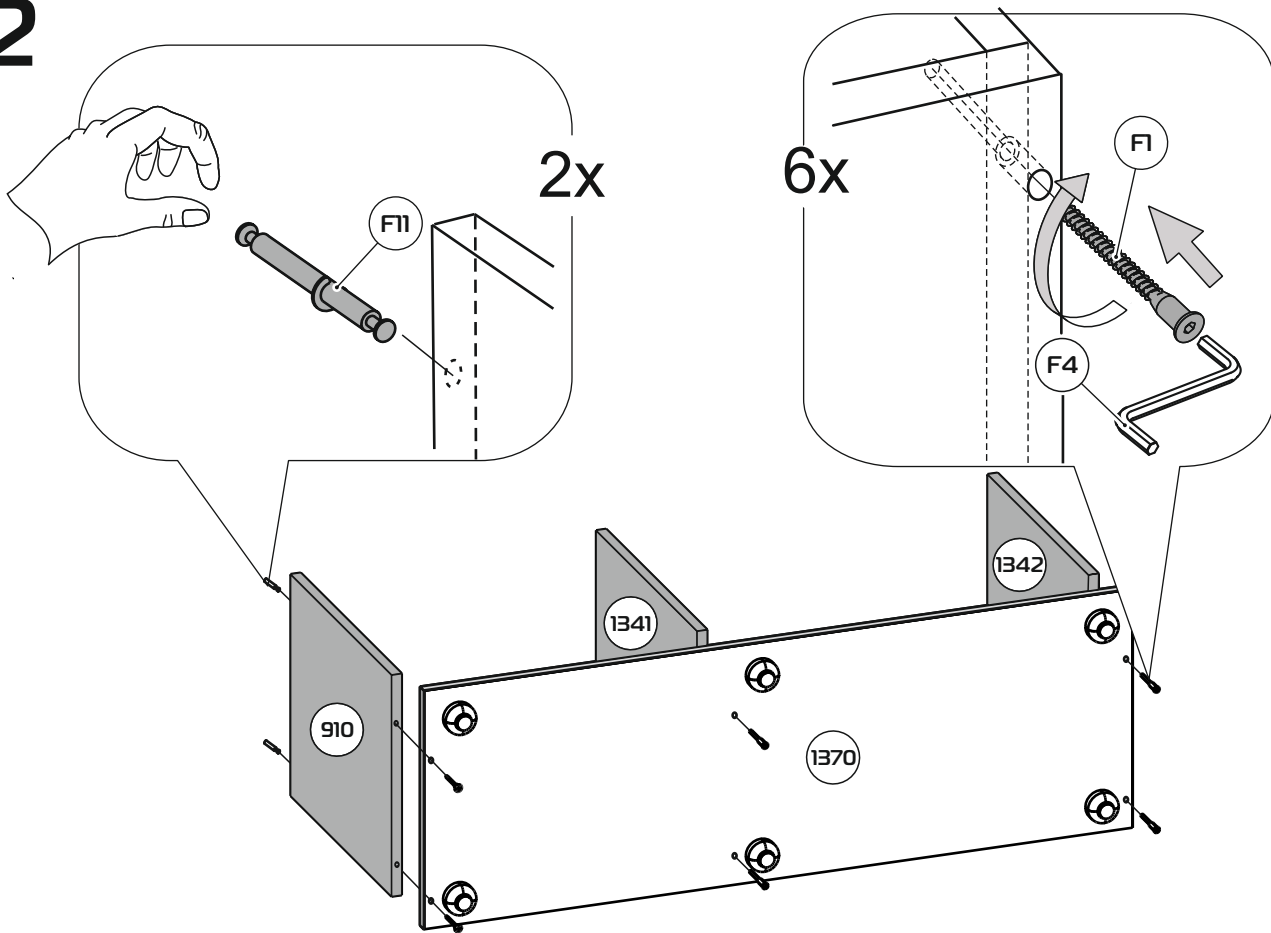

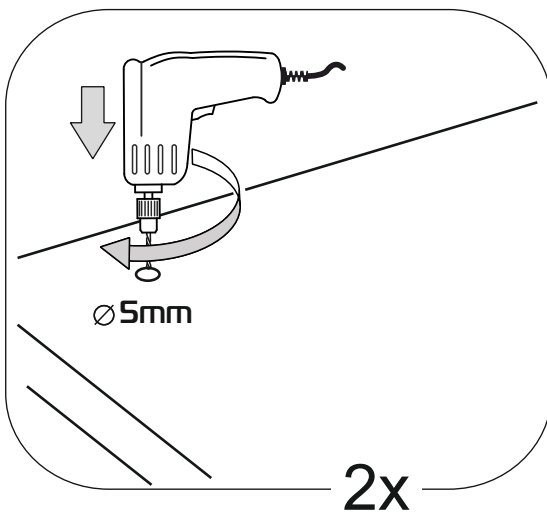
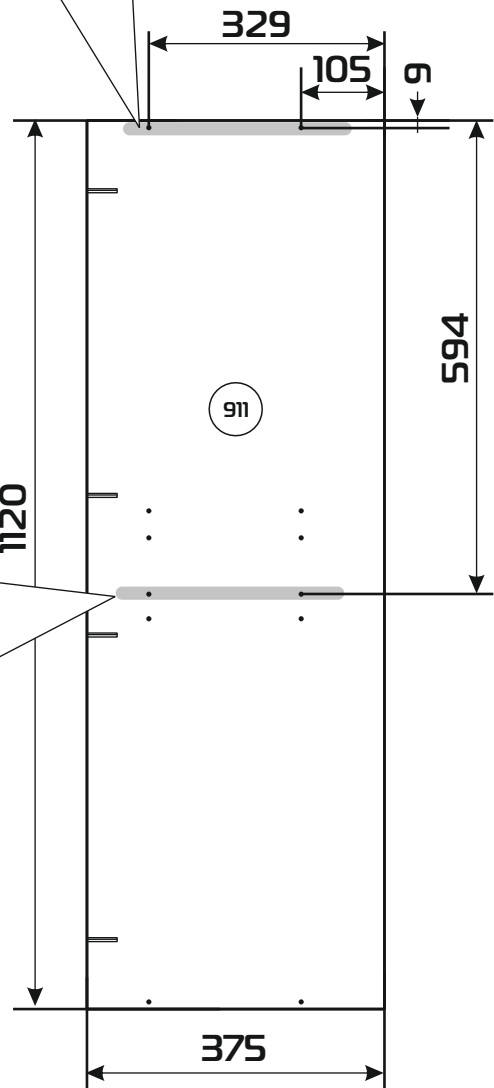
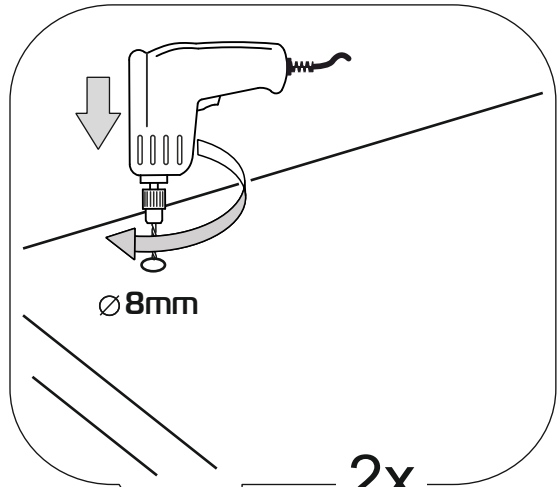
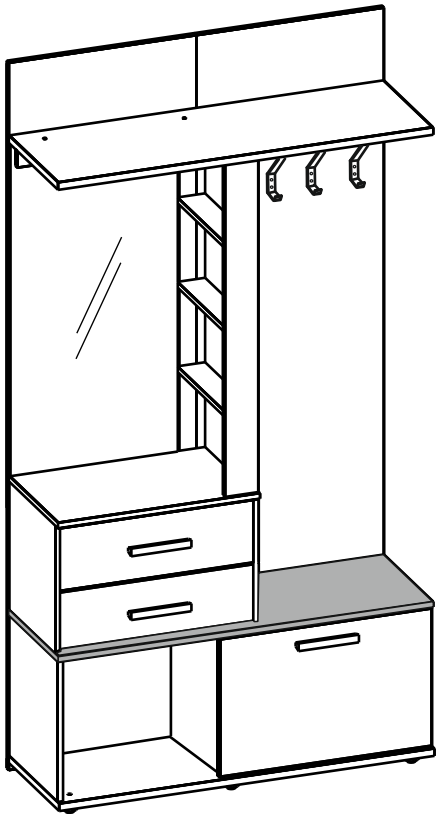

3

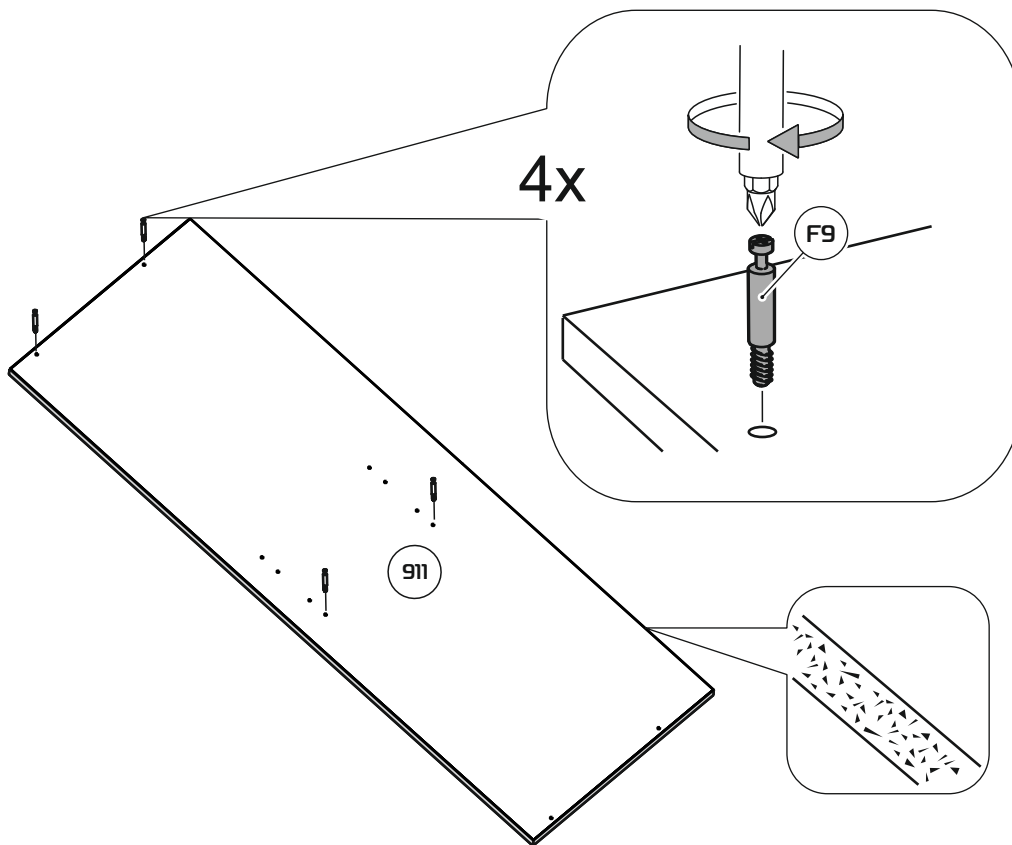

4

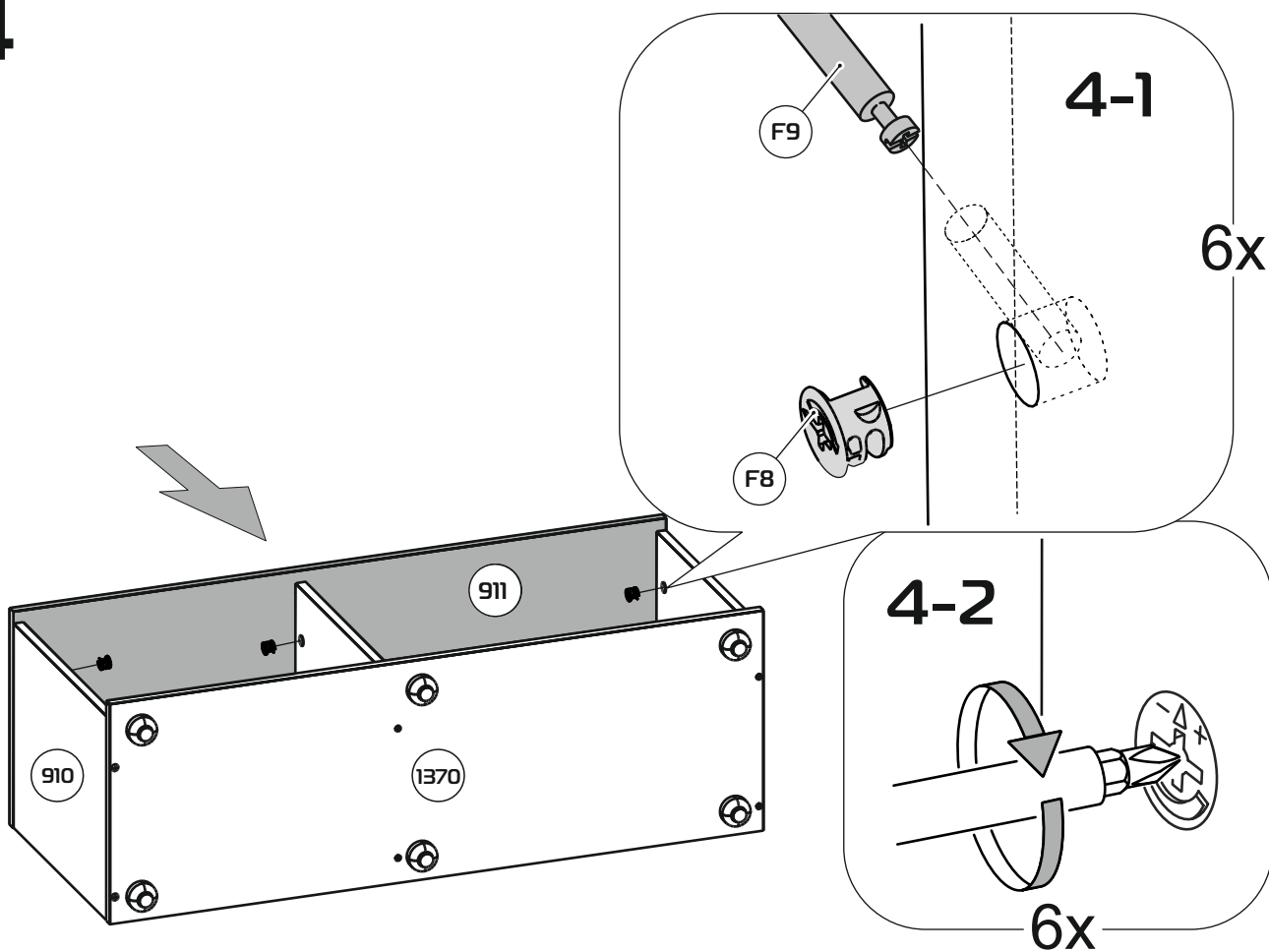

5

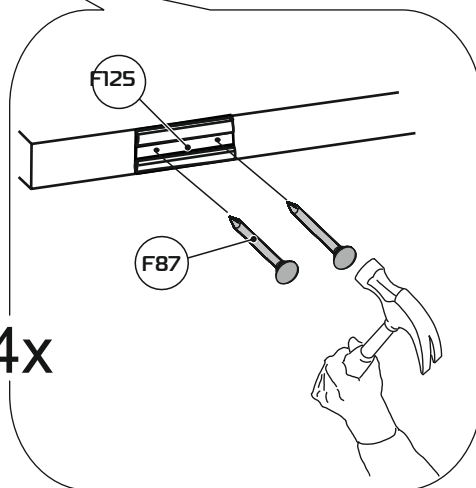
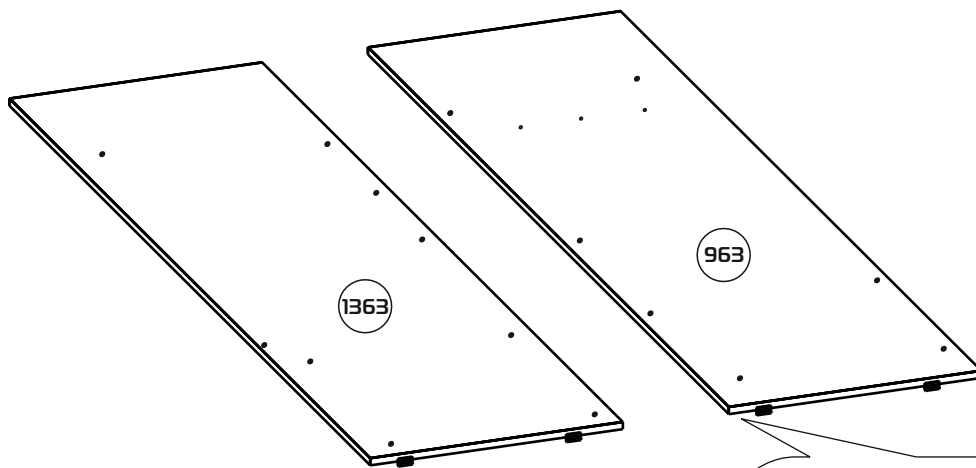

6

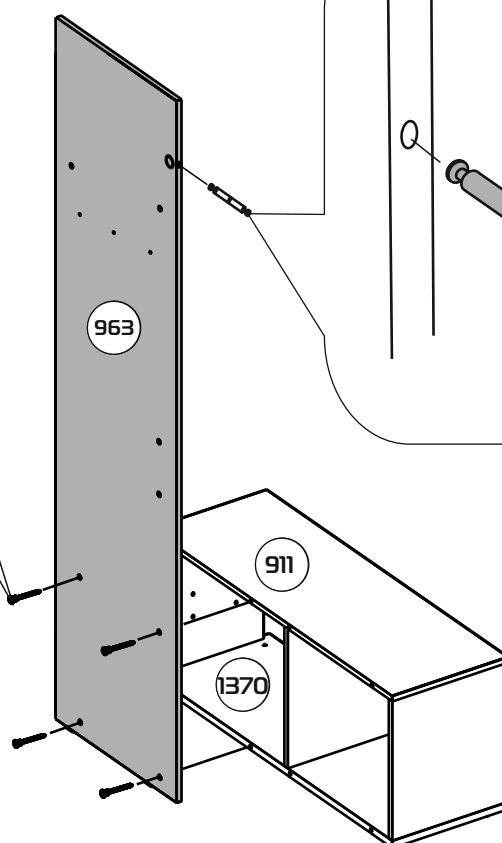
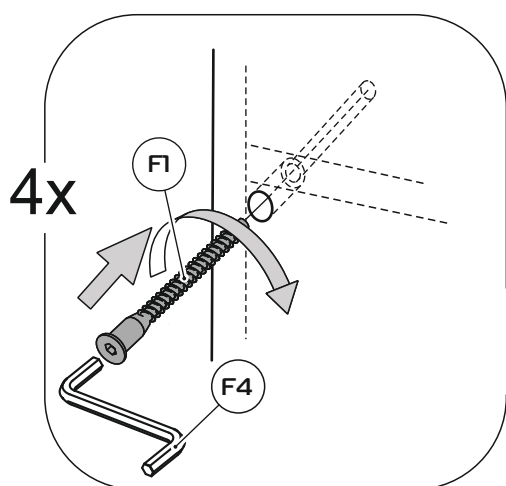

7

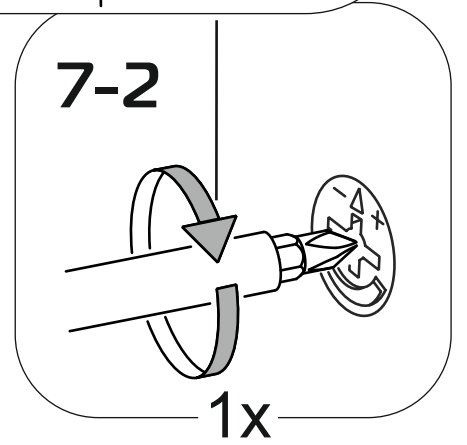
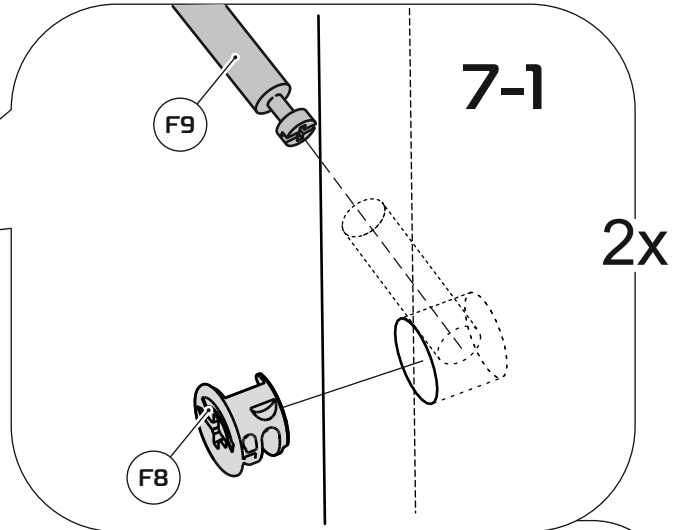
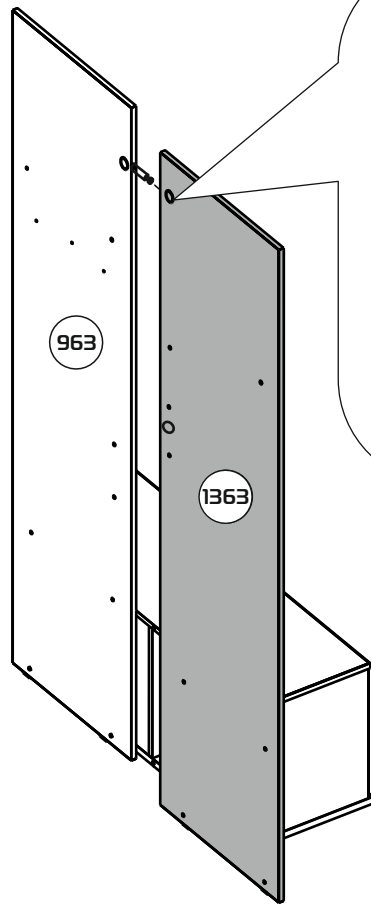

8

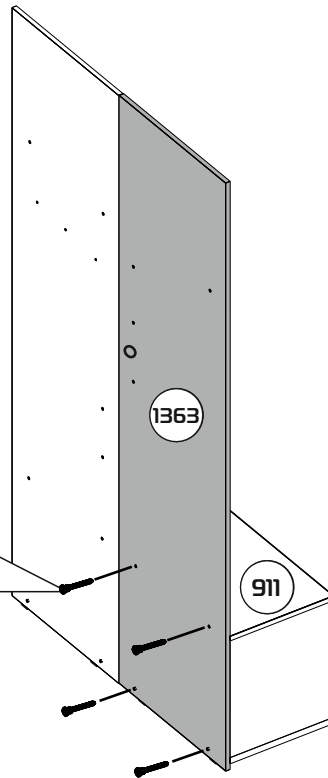
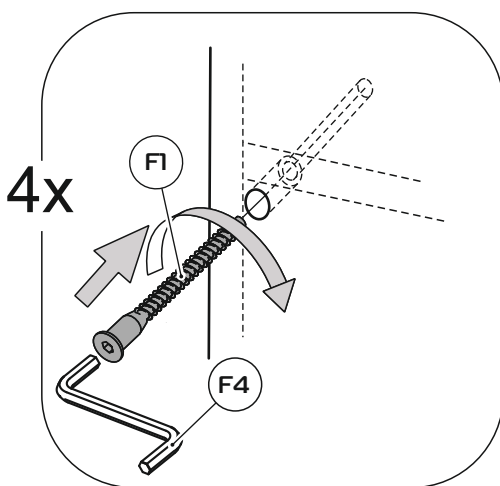

9

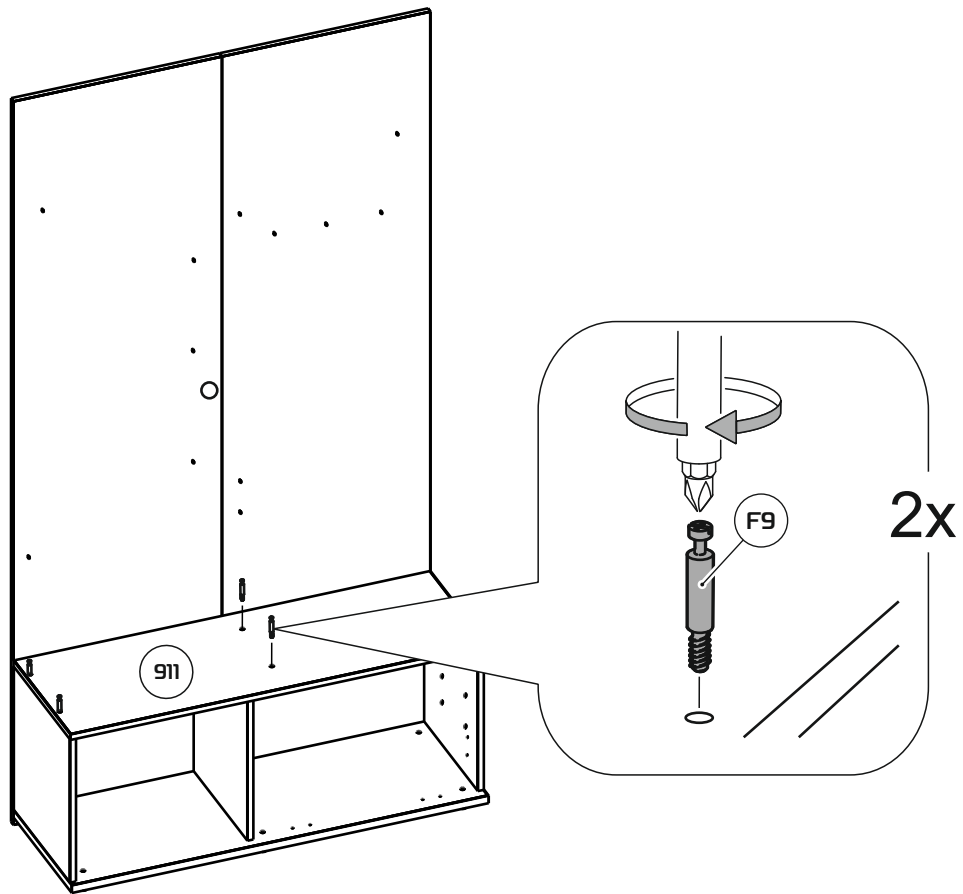

10

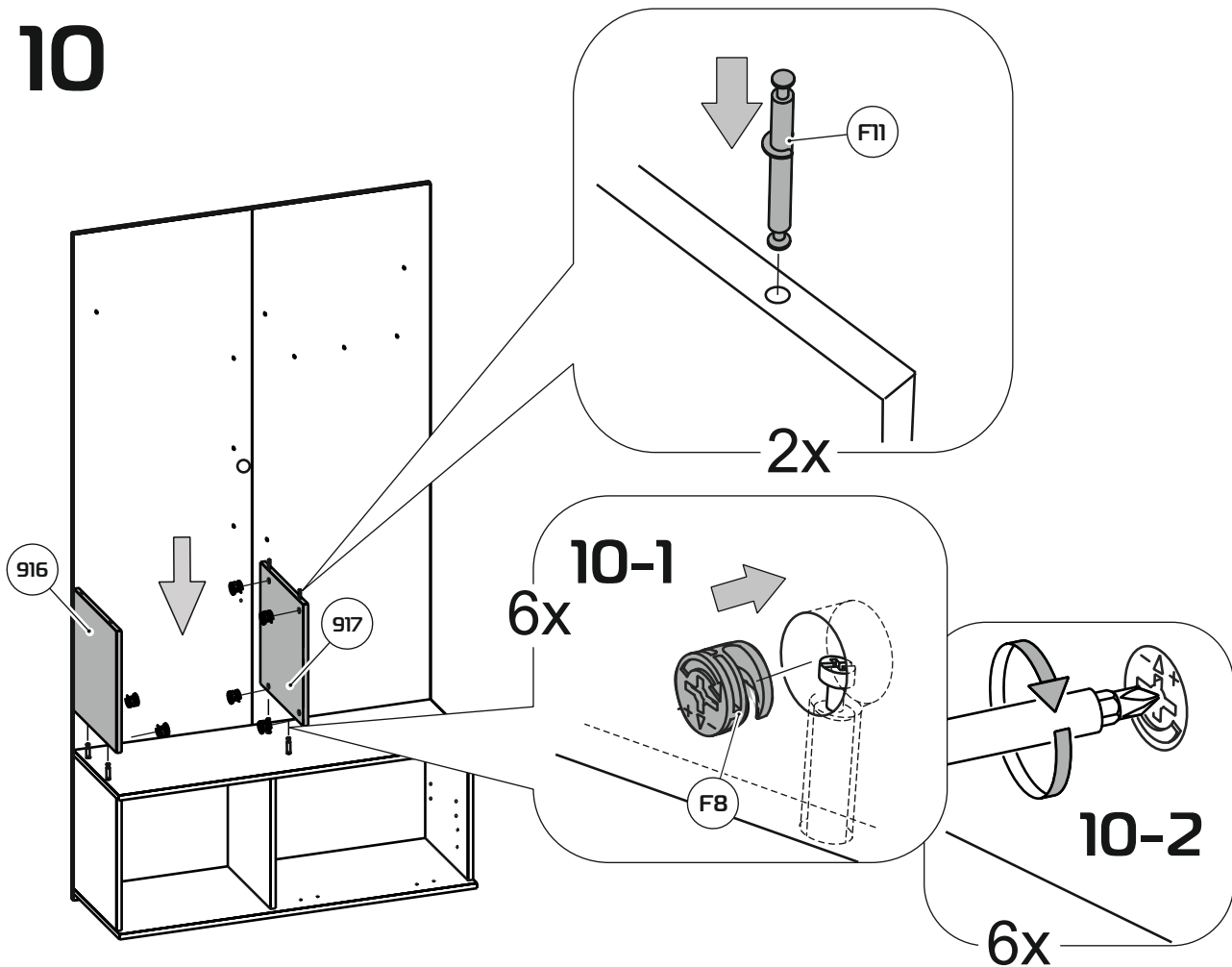

11

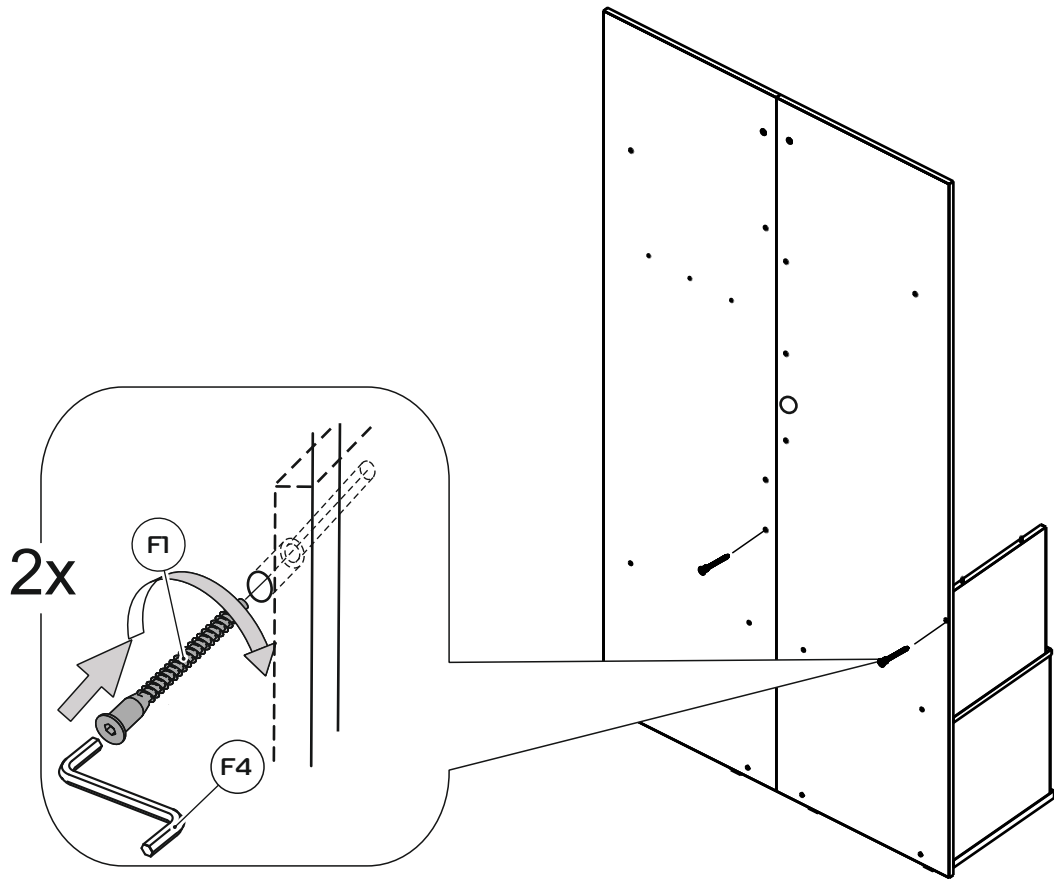

12

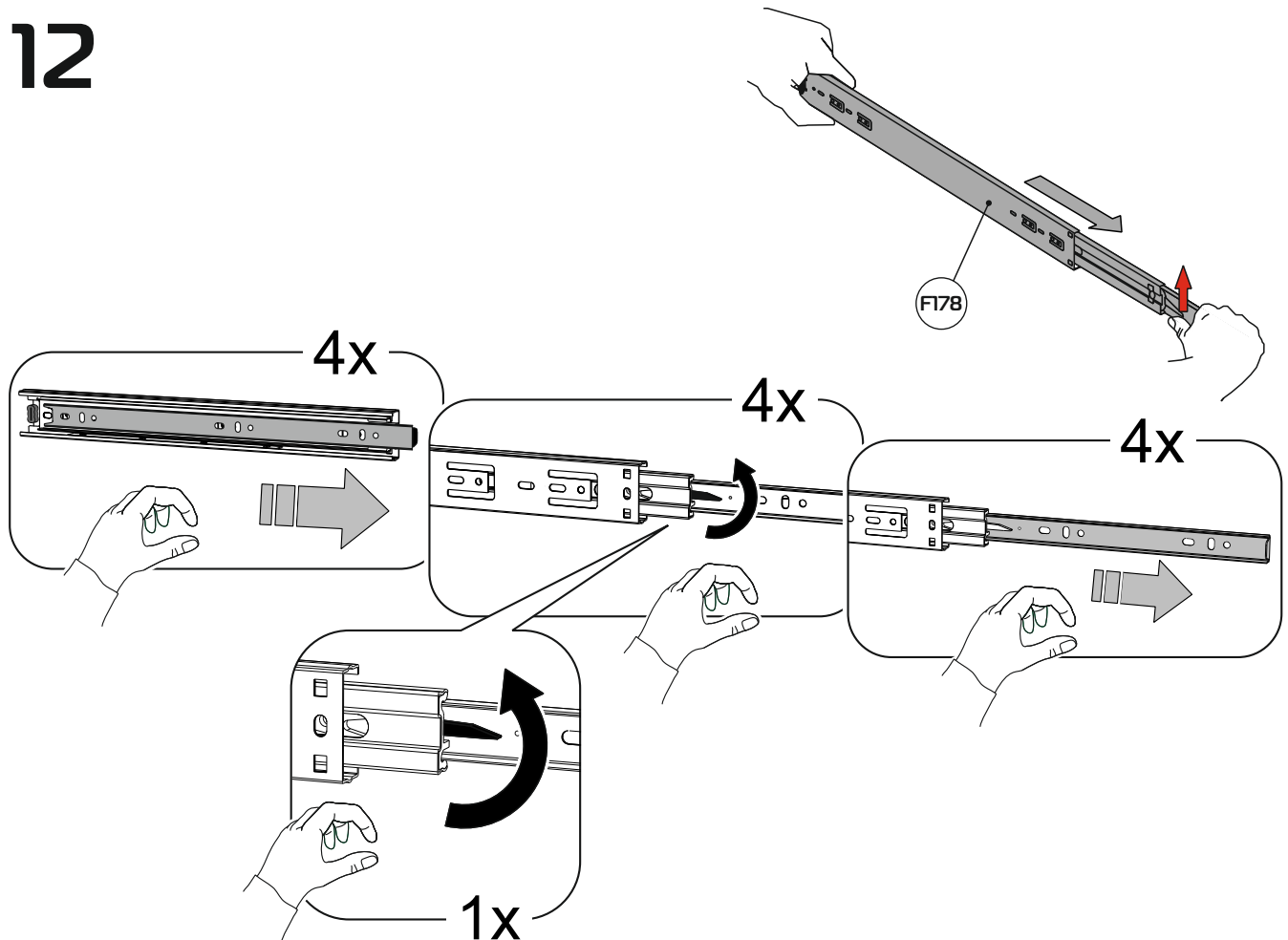

13

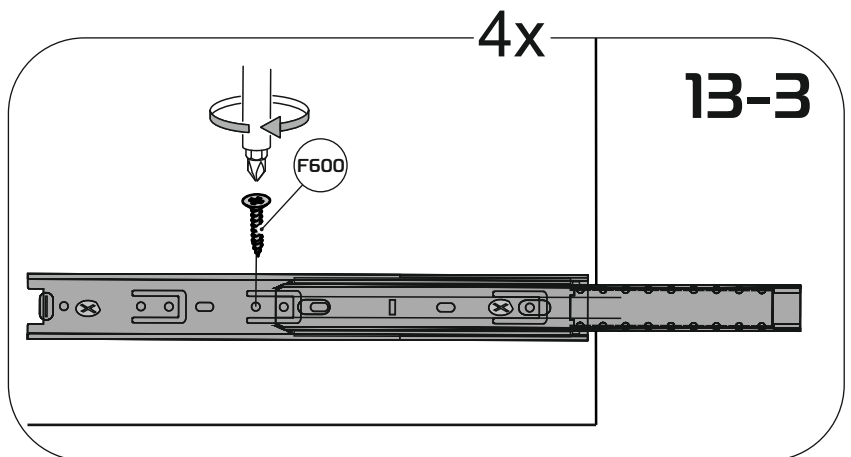
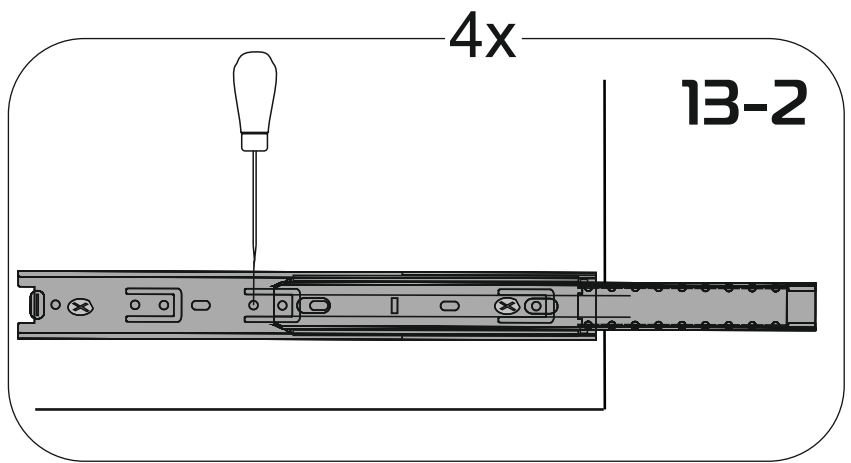
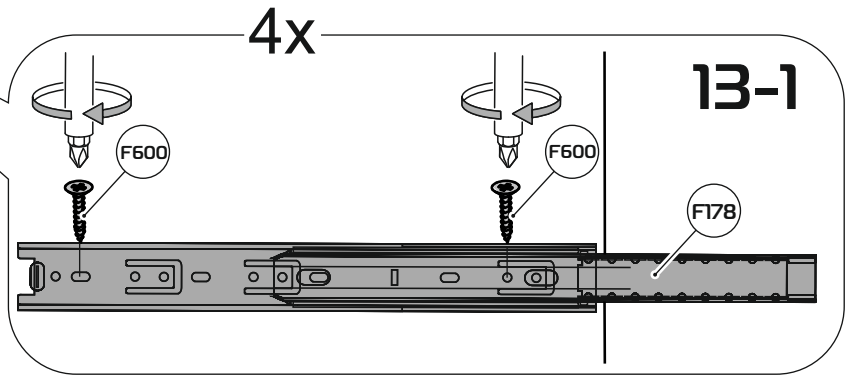
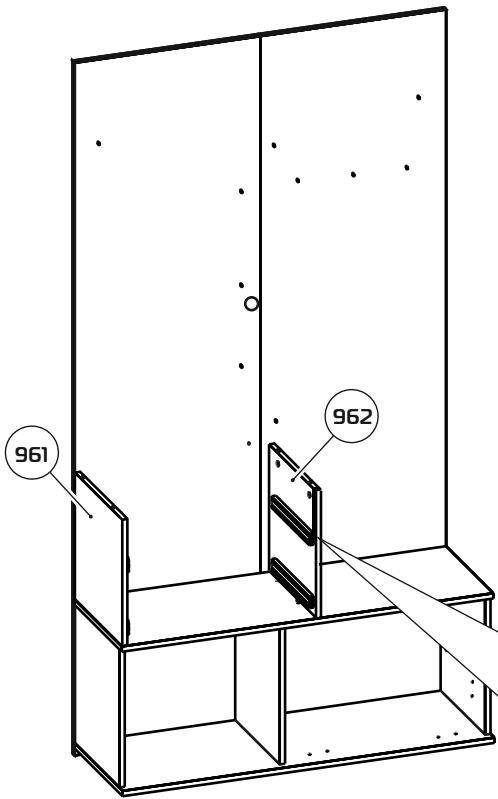

14

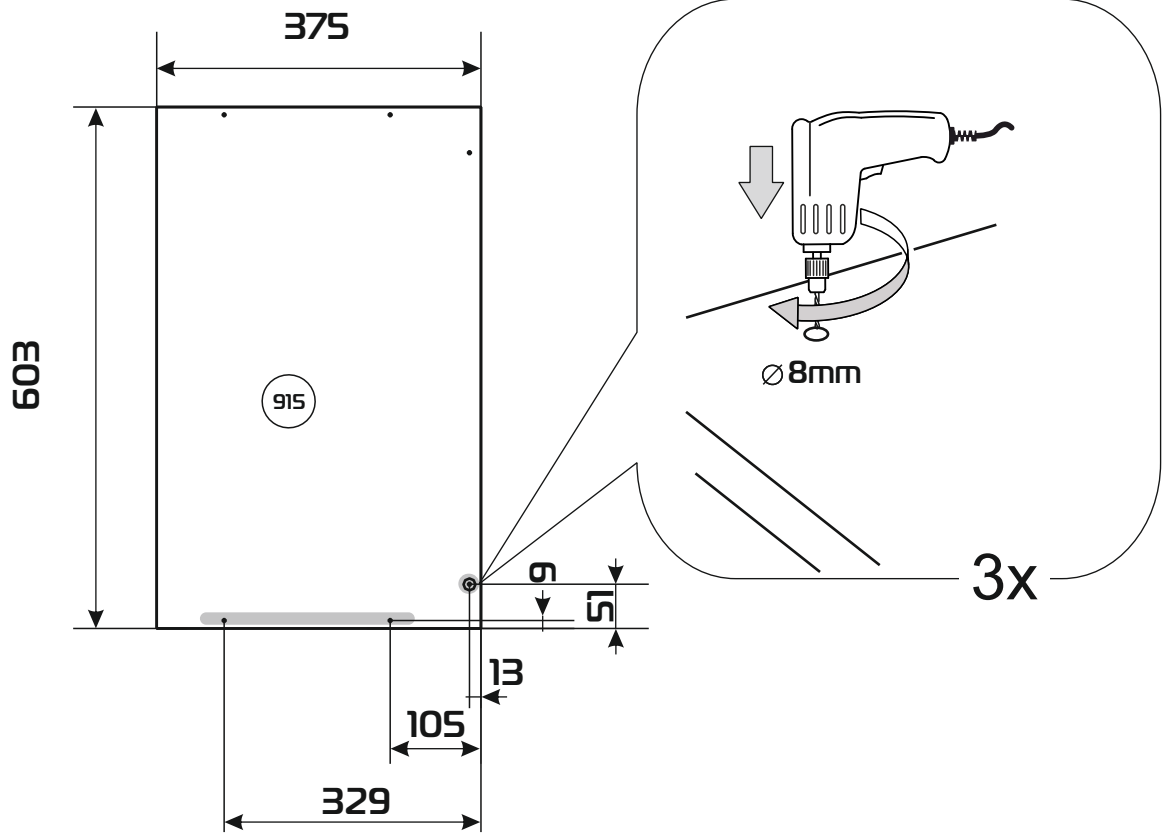

15

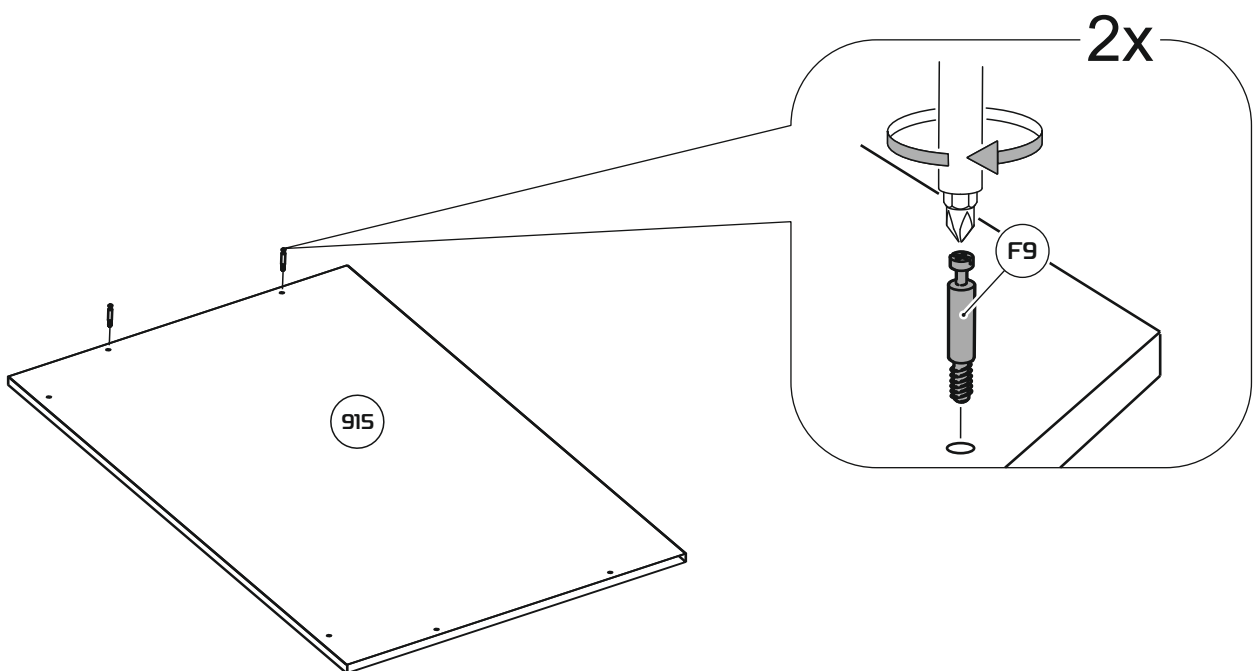

16

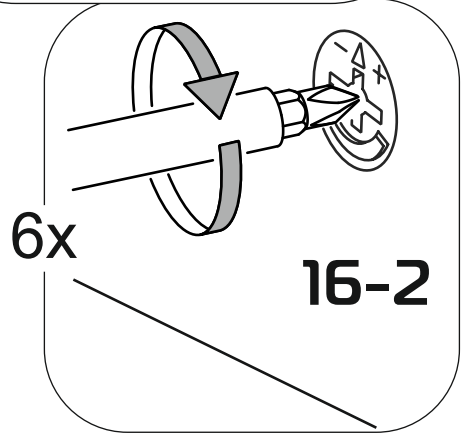
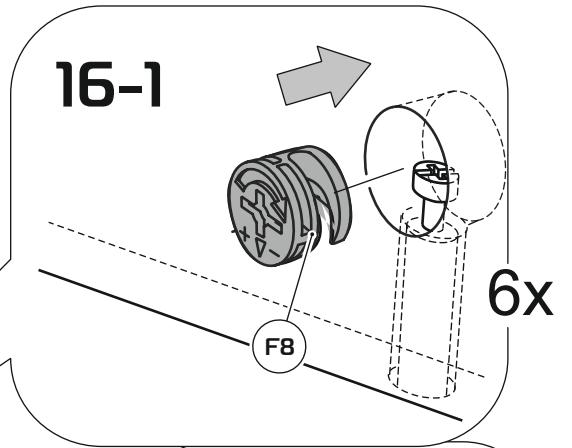
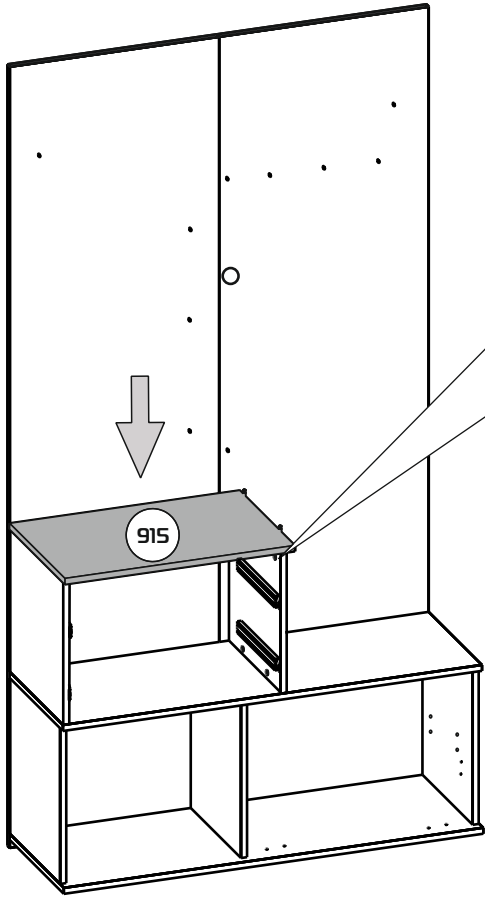

17

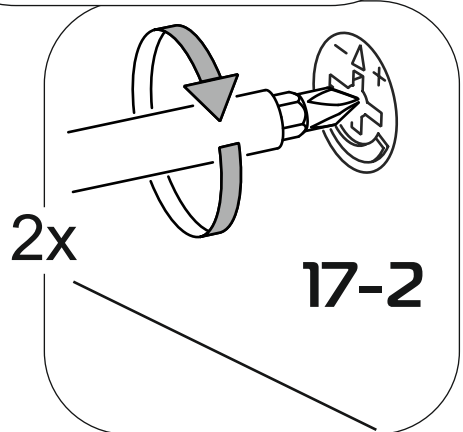
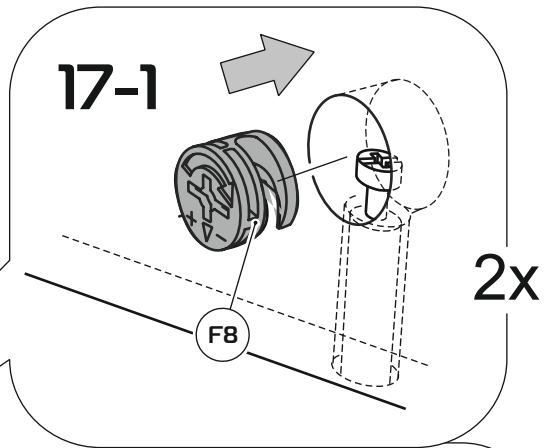
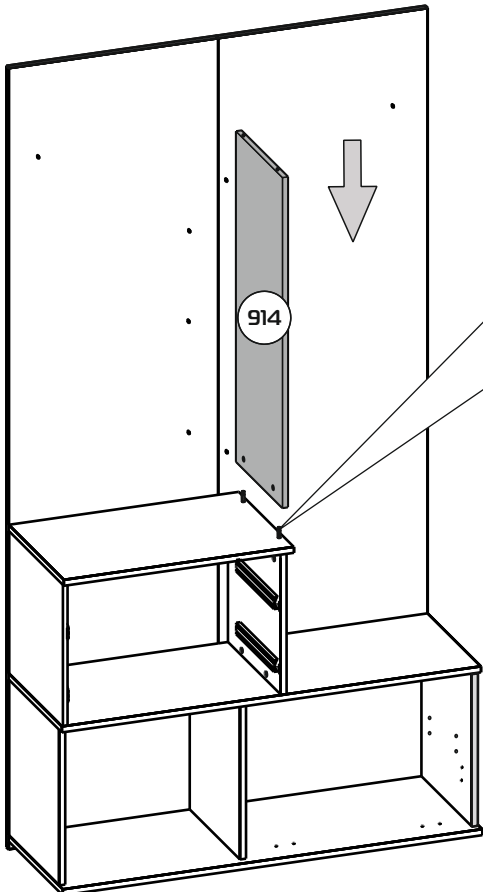

18

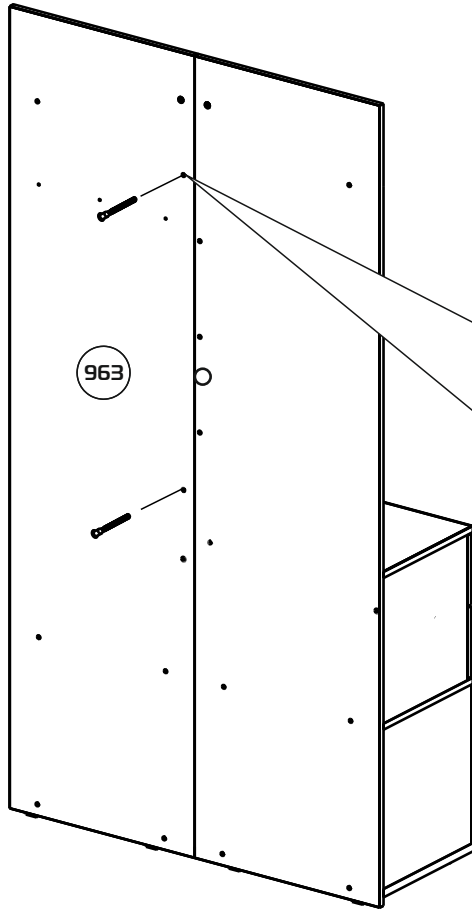

963

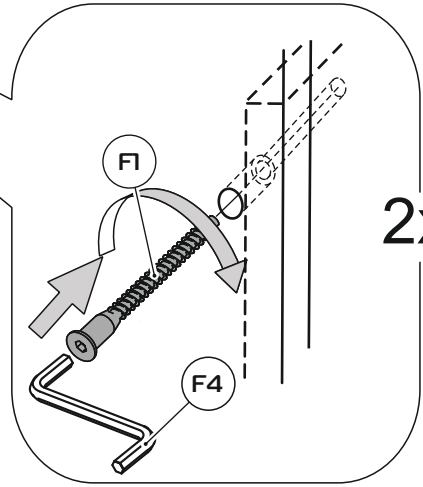

2x

19

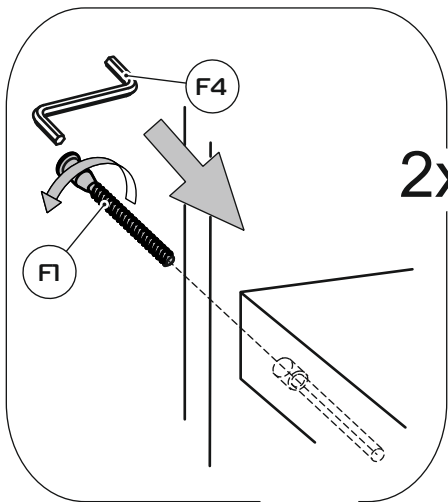

2x

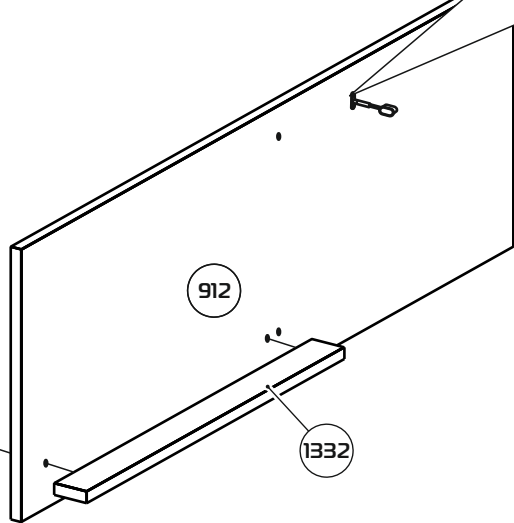

912

1332

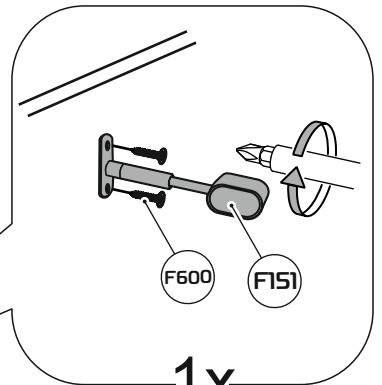

1x

20

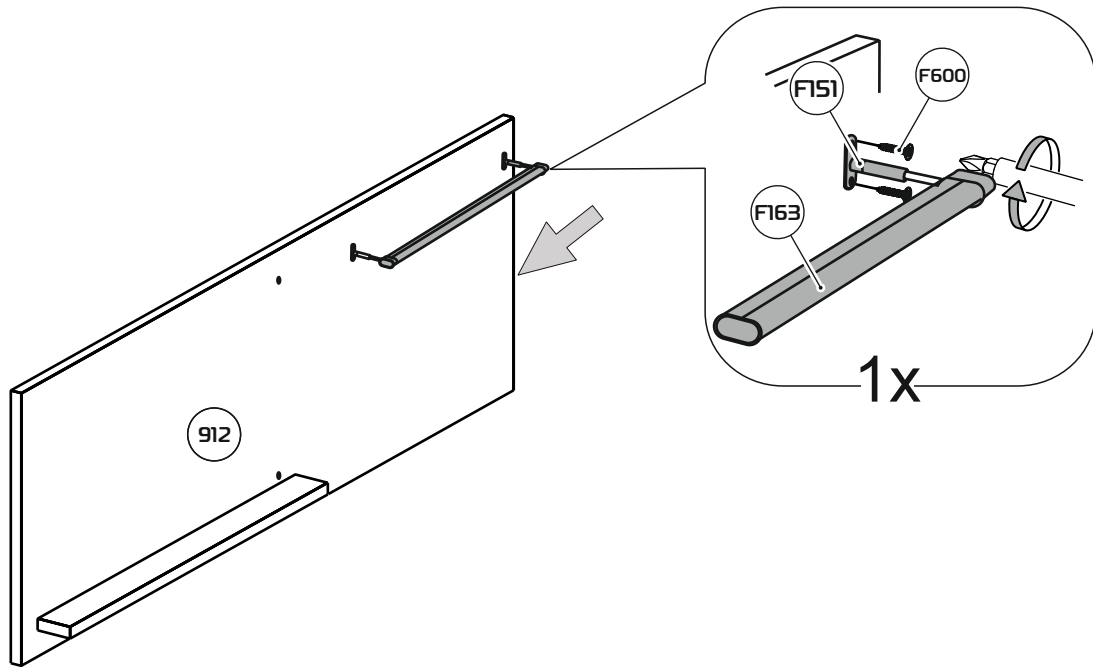

21

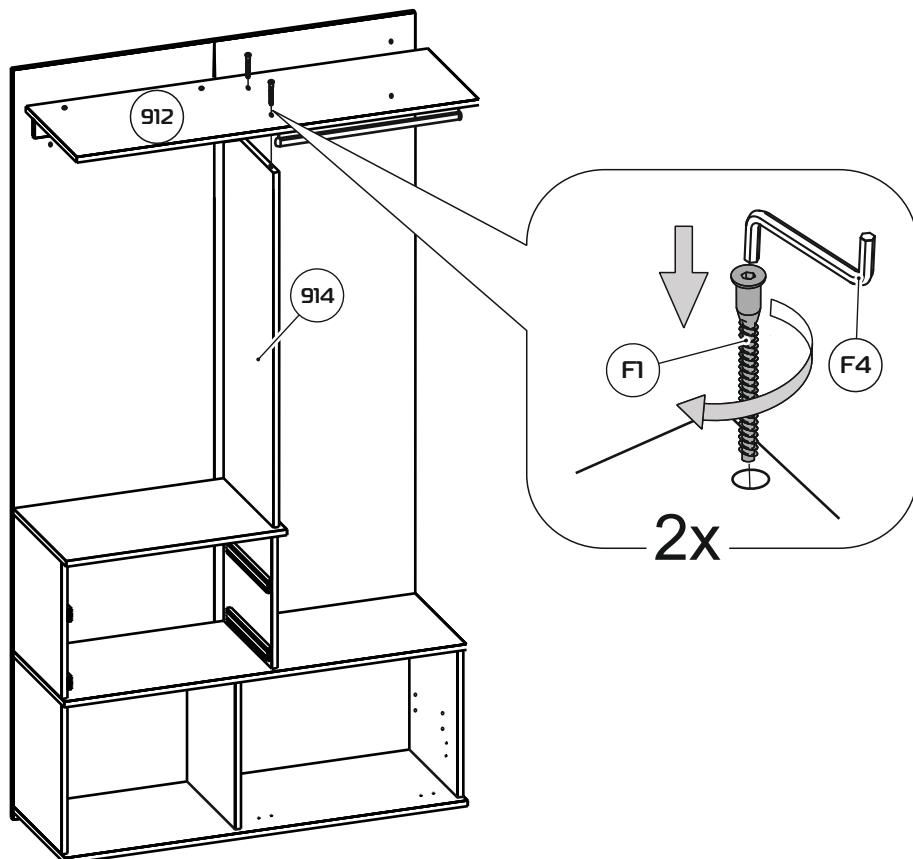

22

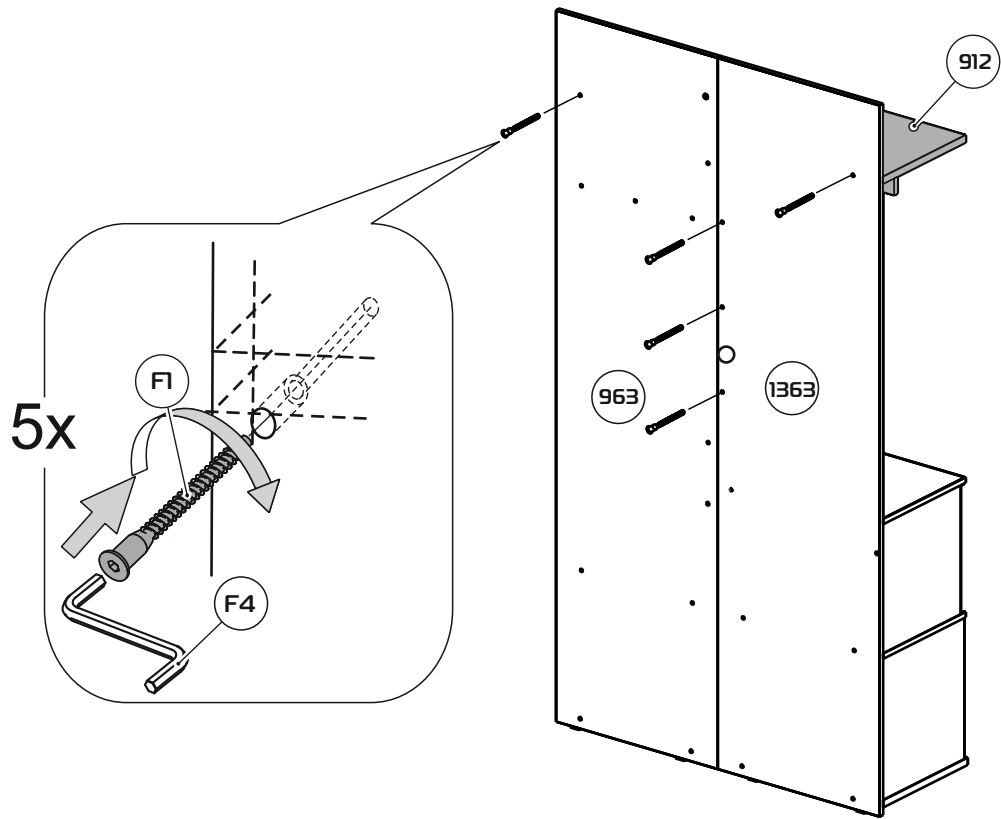

23

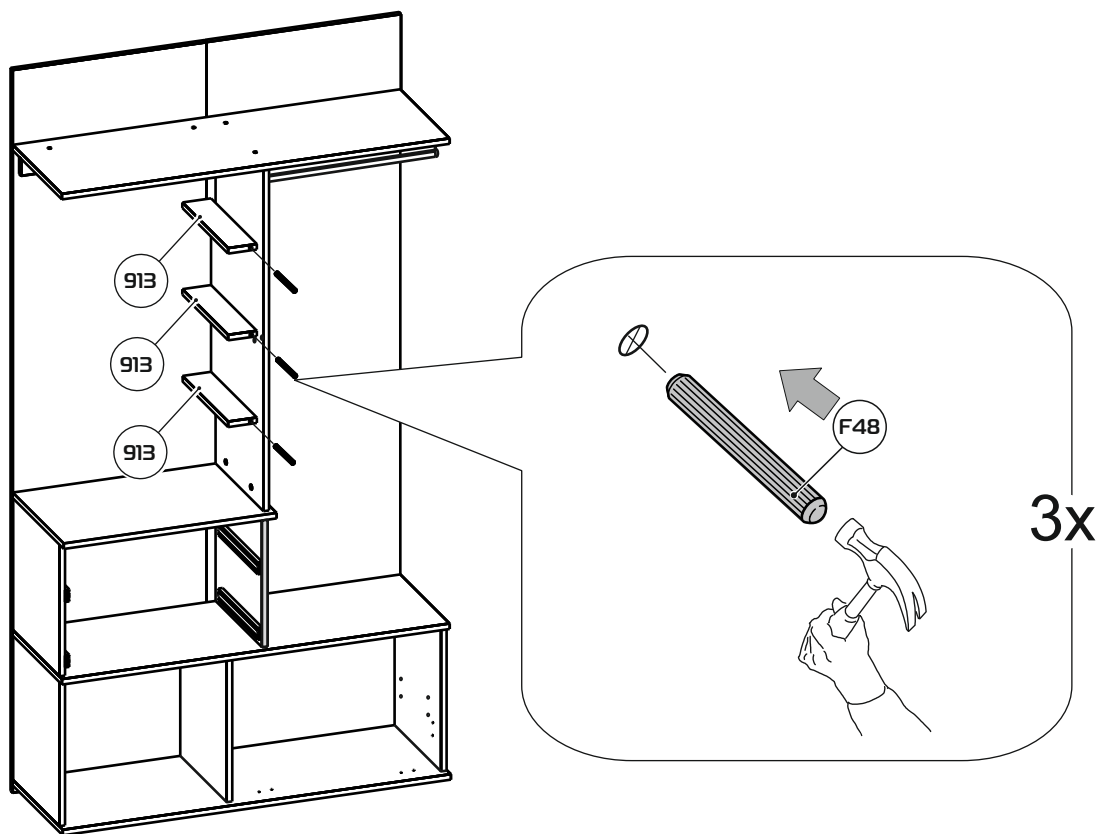

24

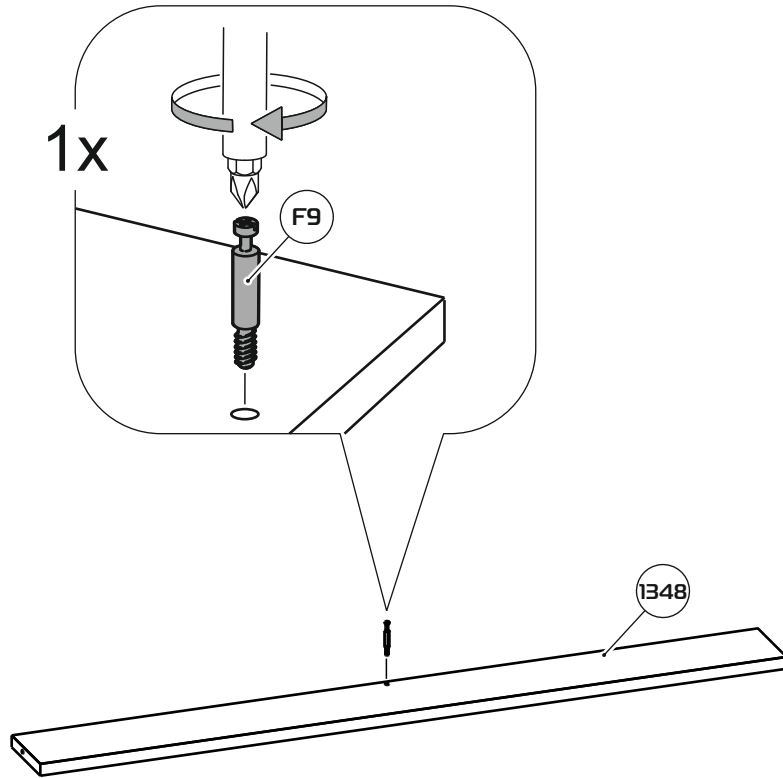

25

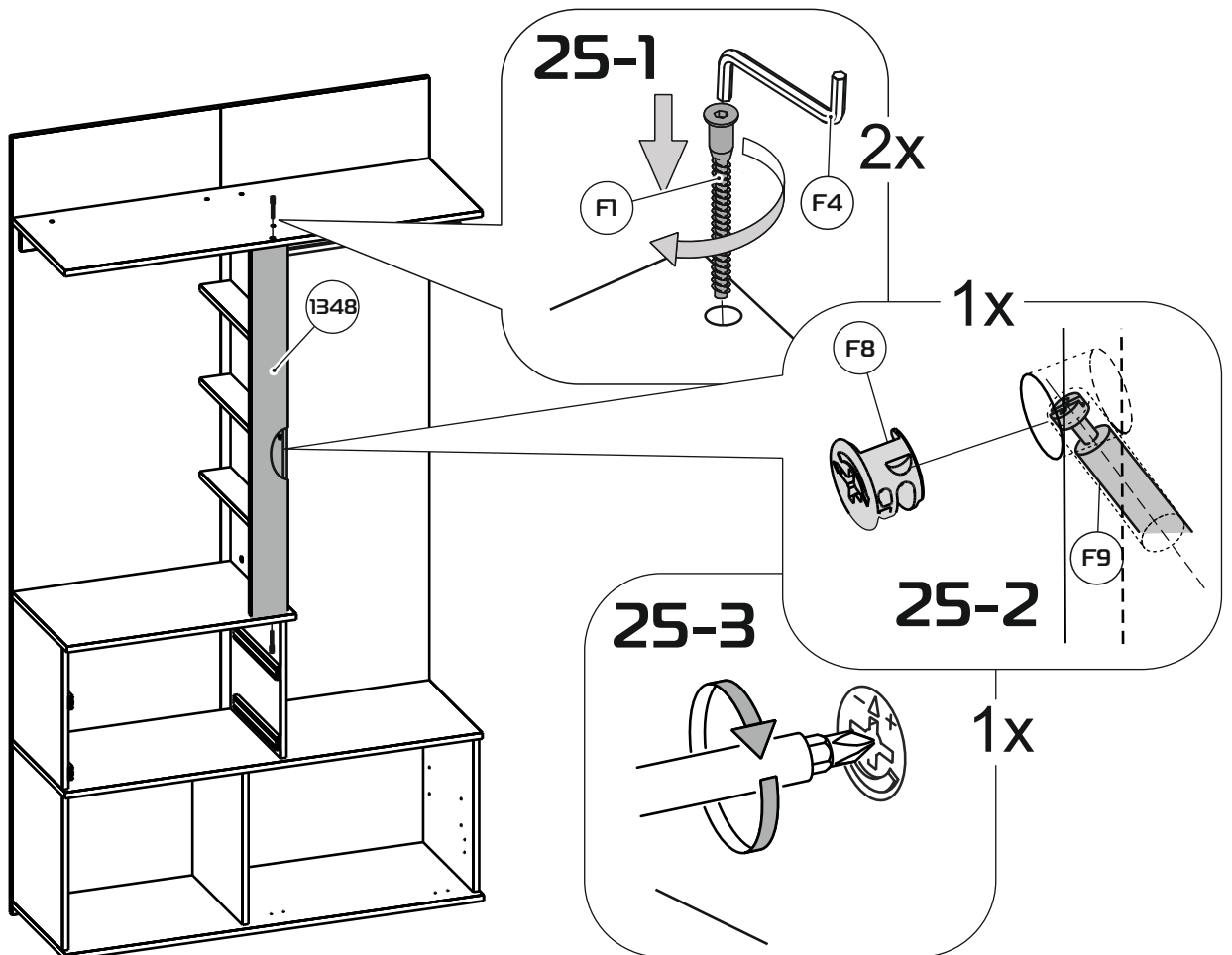

26

26

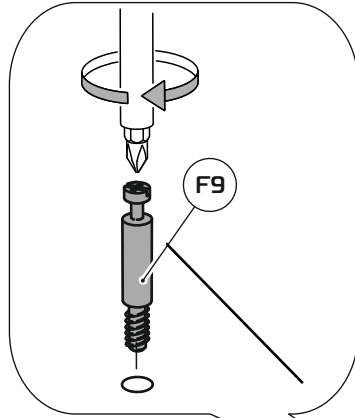

2x

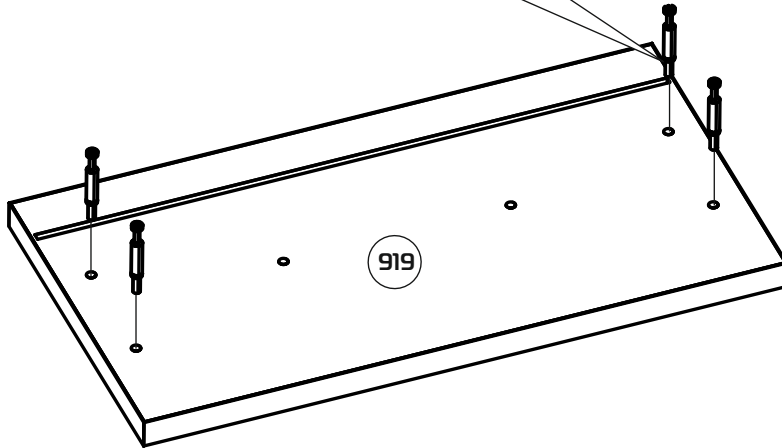
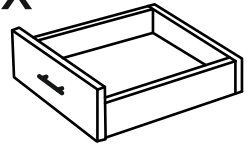

27

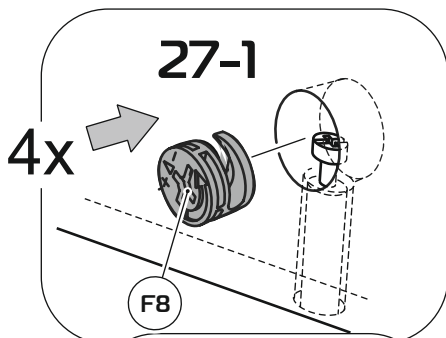

2x

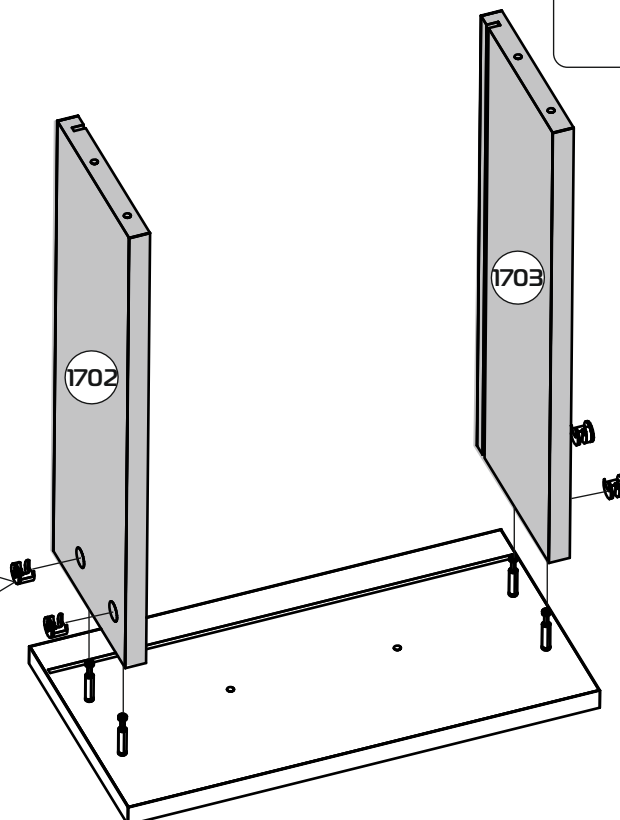
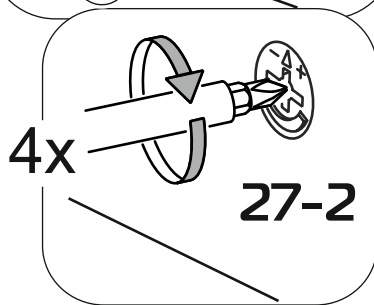
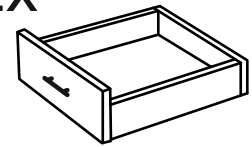

28

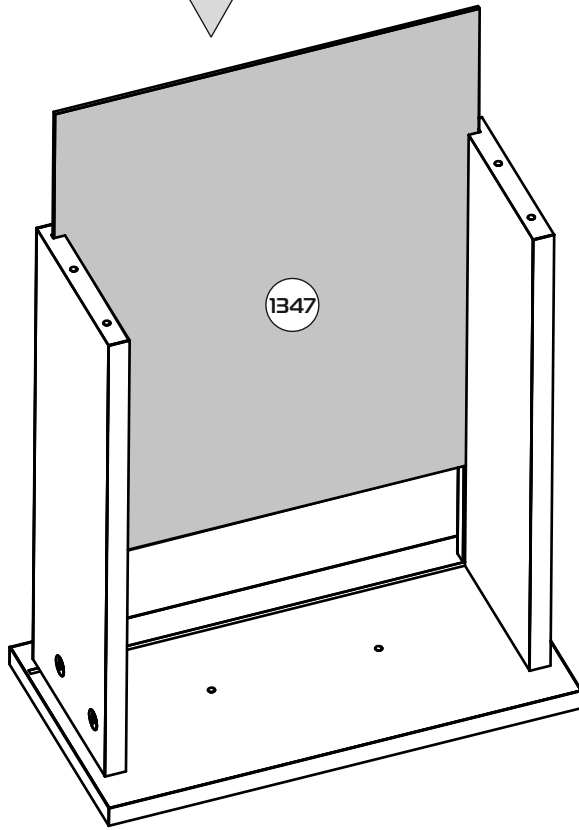
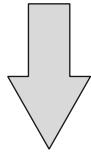

2x

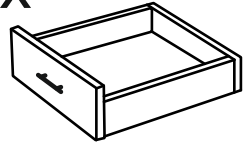

29

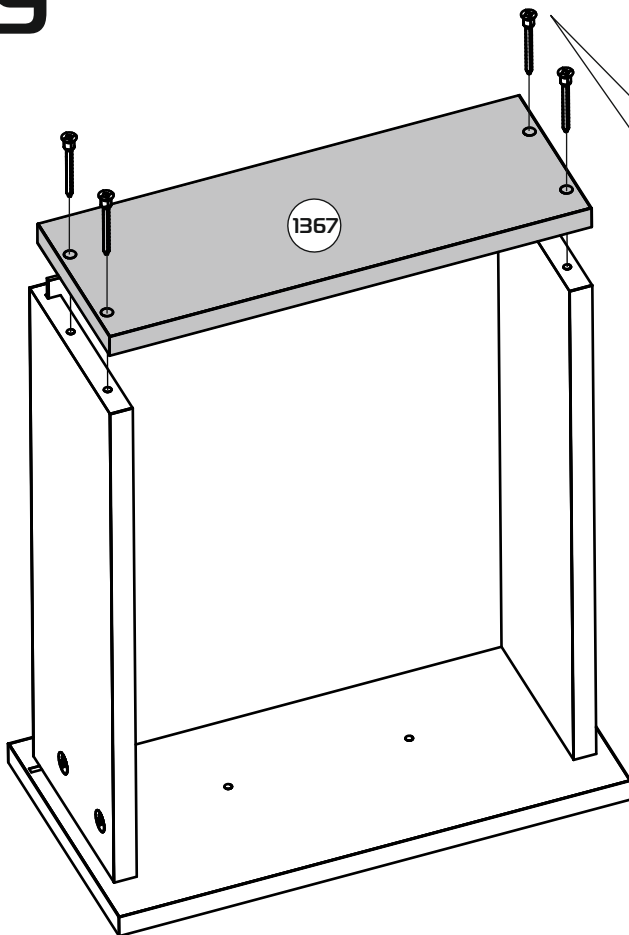

2x

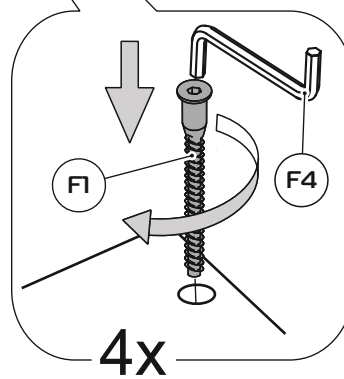
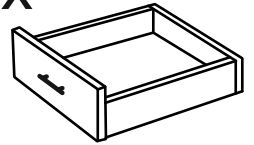

30

2x

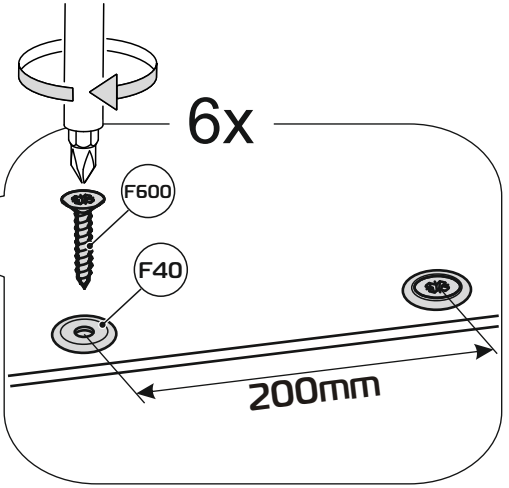
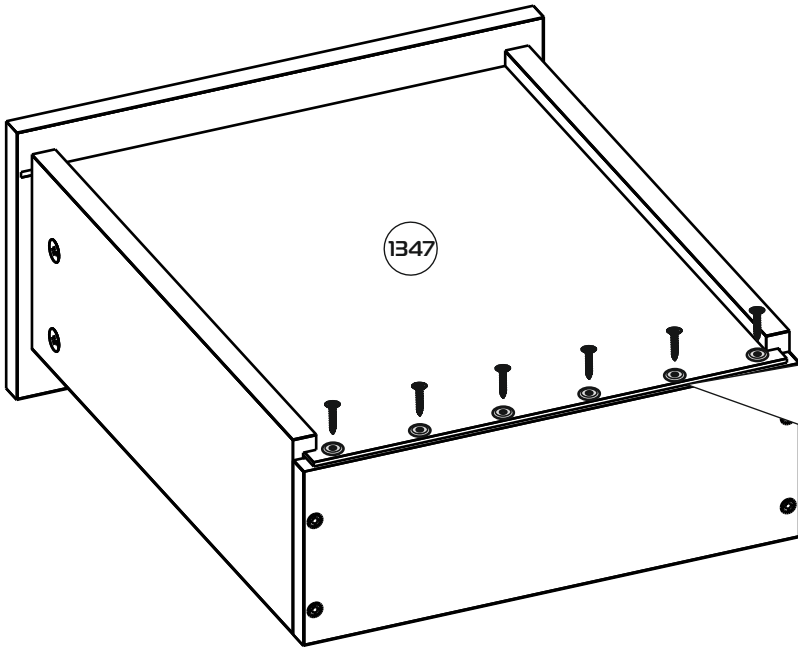
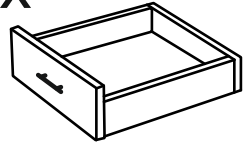

31

2x

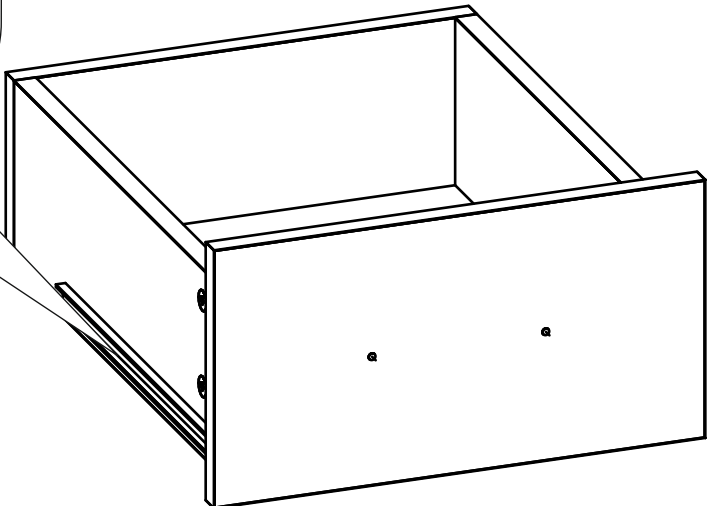
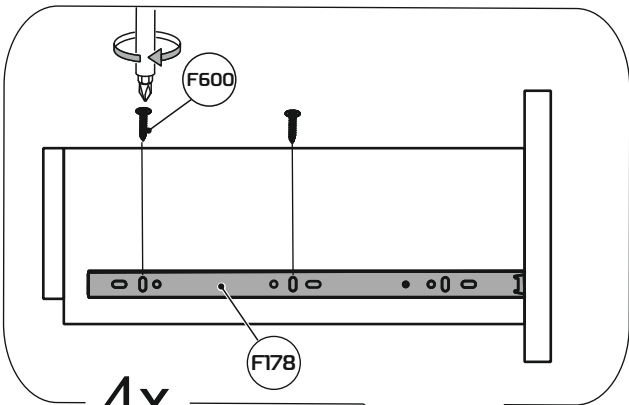
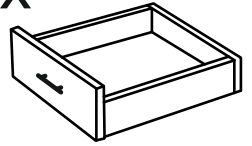

32

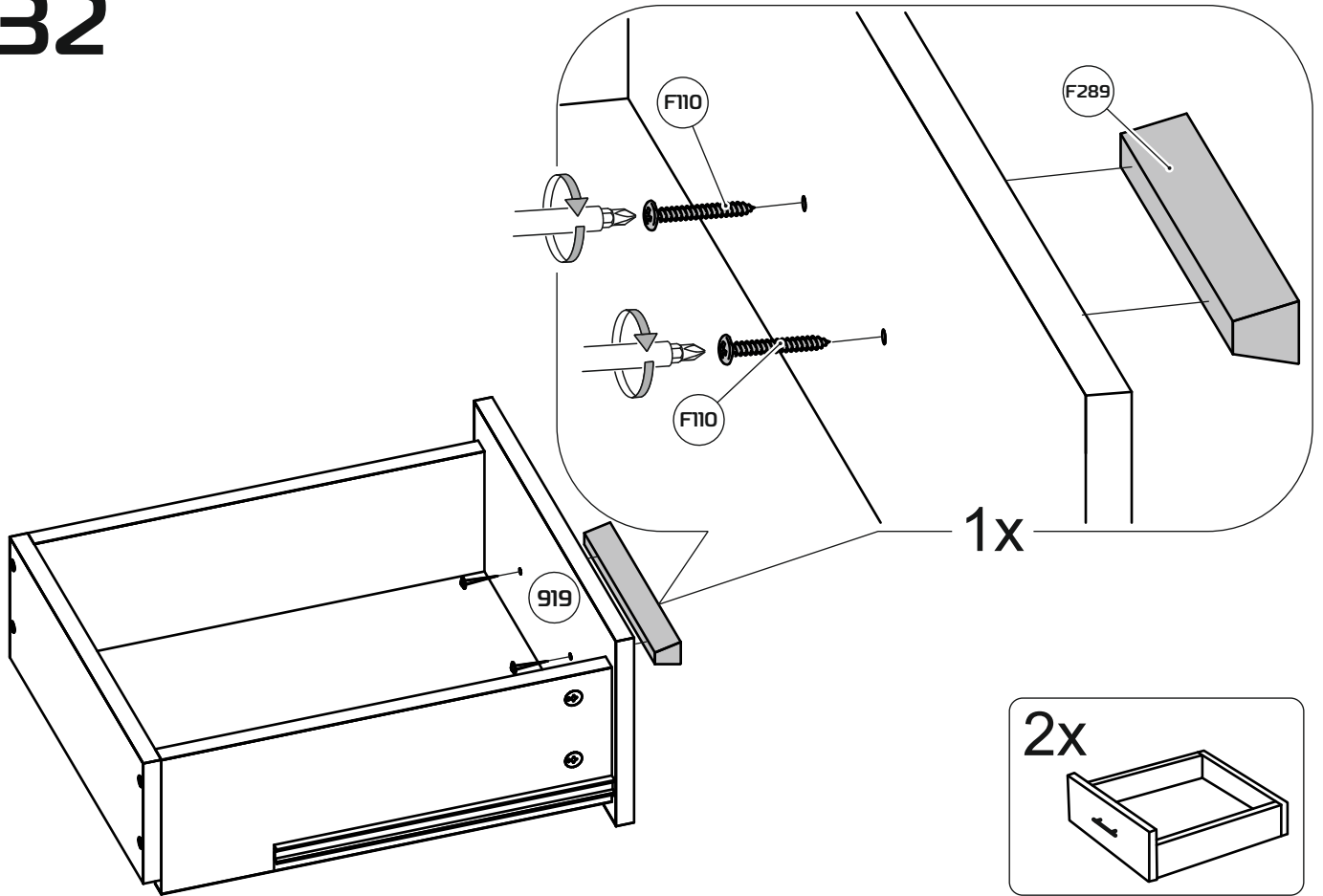

33

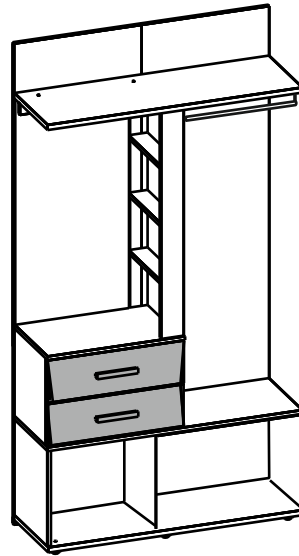
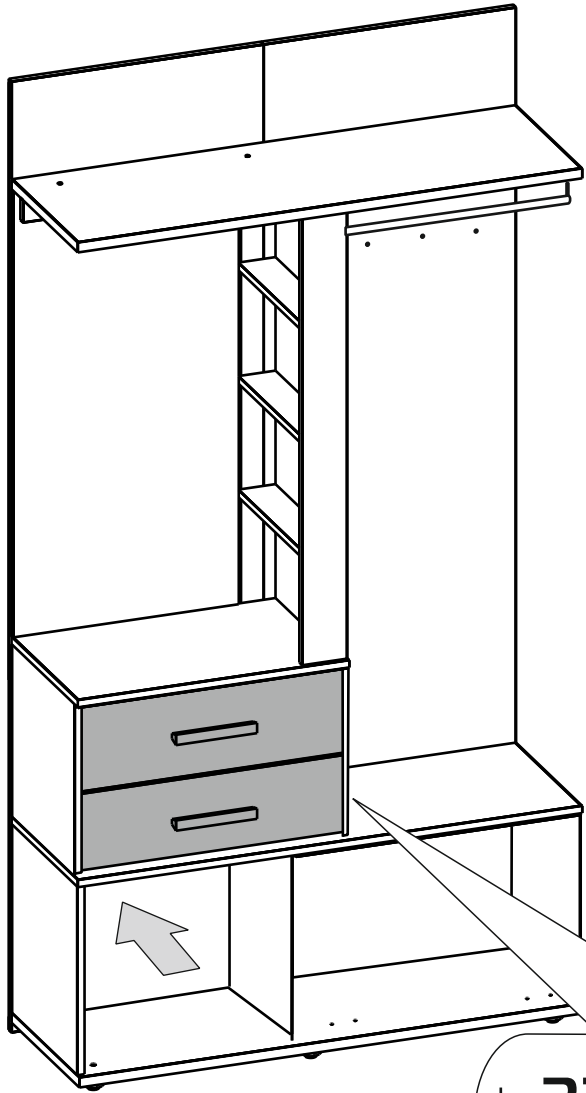

33-1

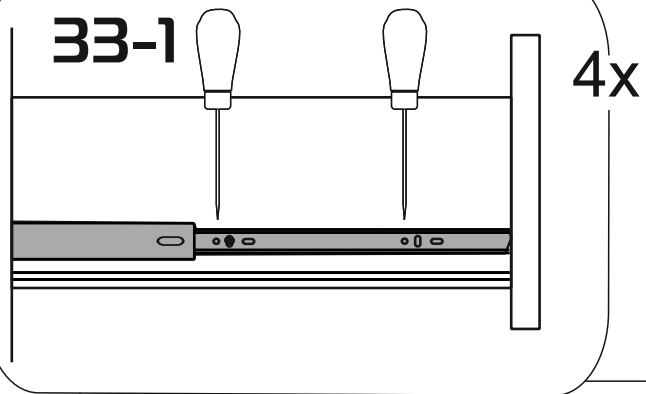

33-2

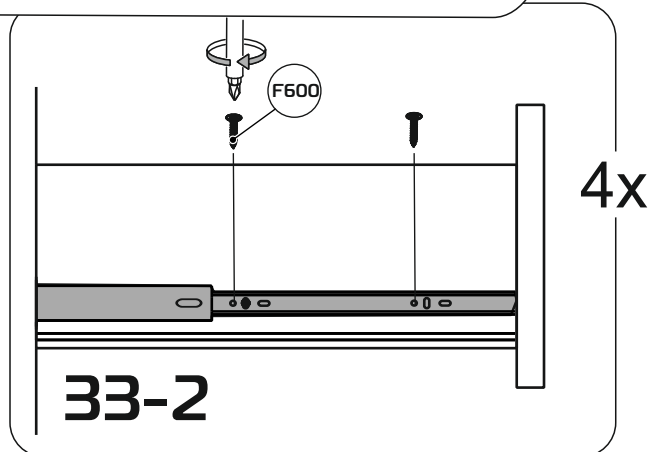

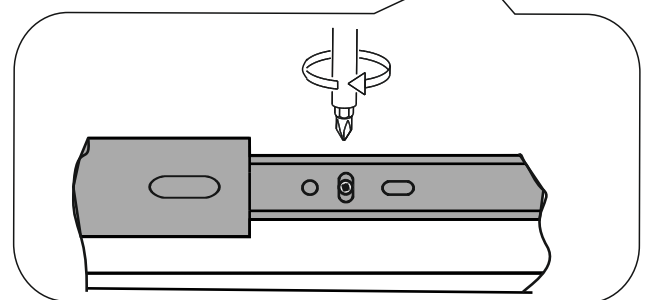
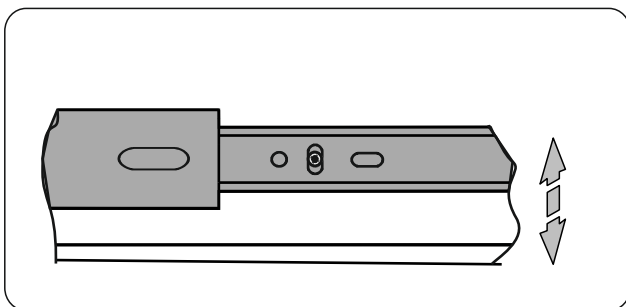
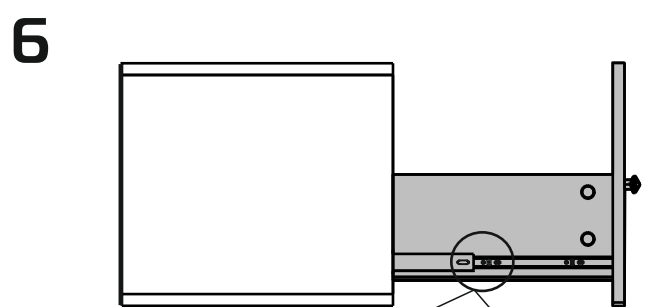
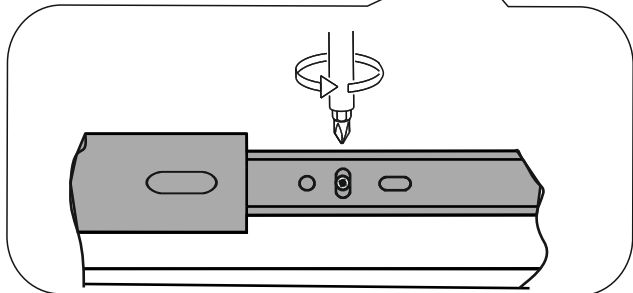
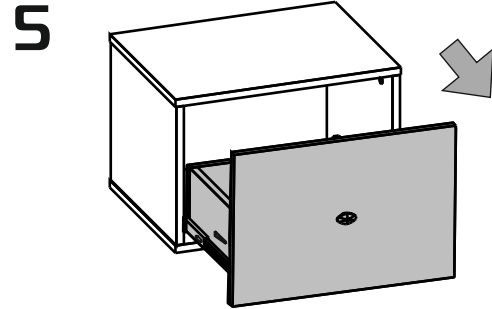
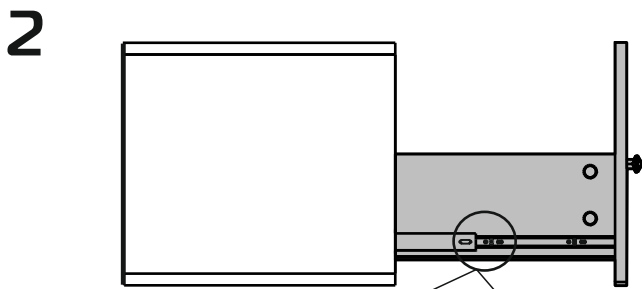
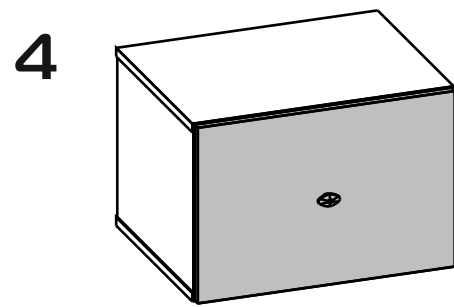
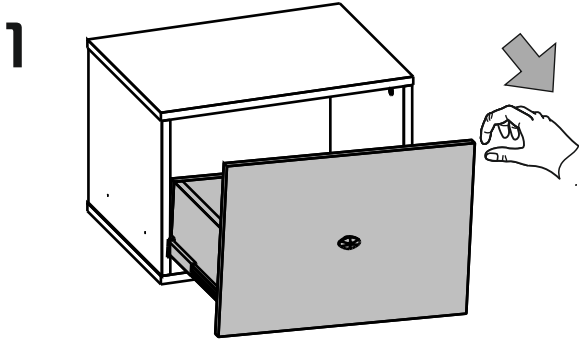
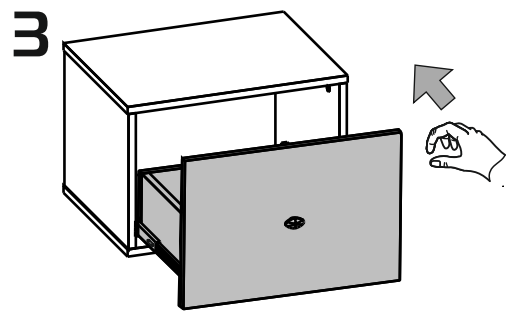
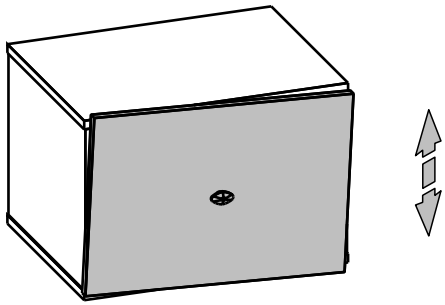

34

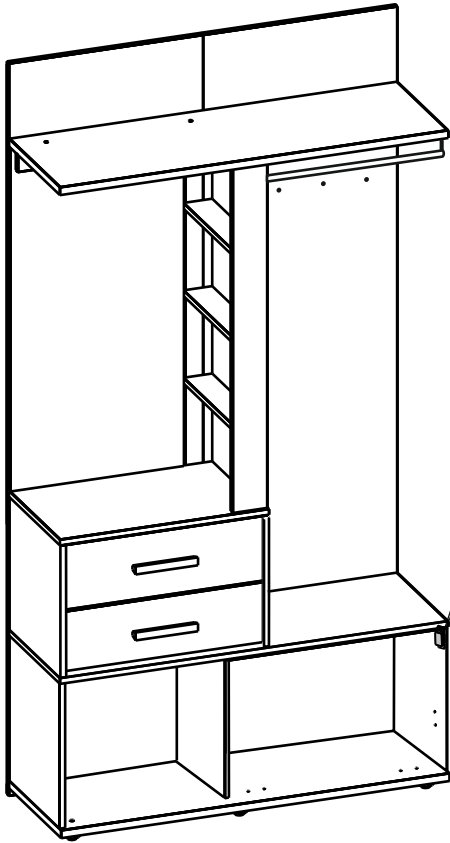

2x

34-1

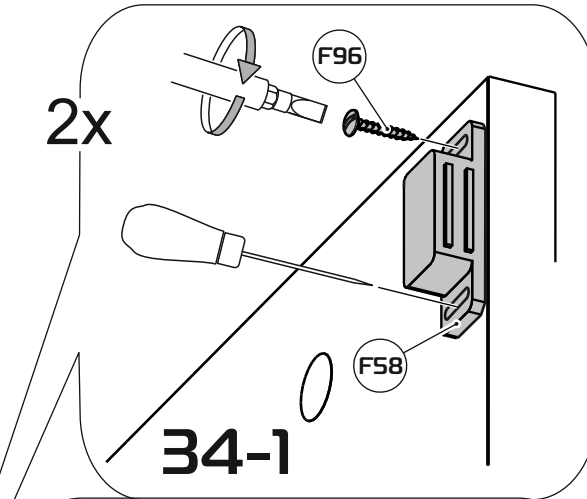

F96

EKE



34-2

2x

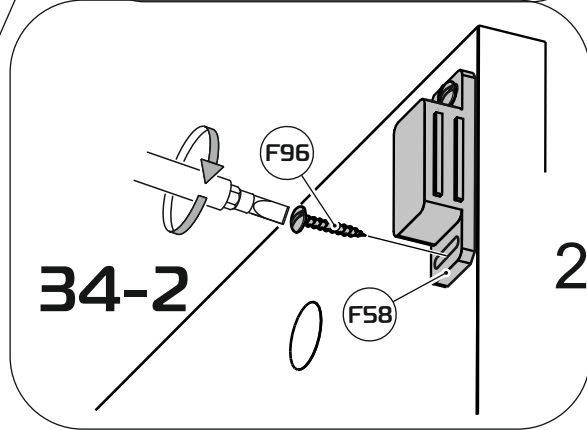

F97

EKE



35



A

F58

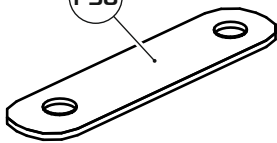

2x

F97

F58

F97

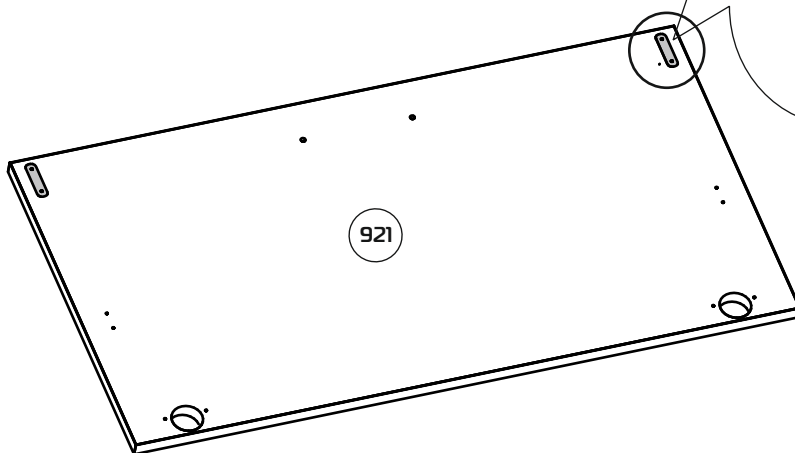
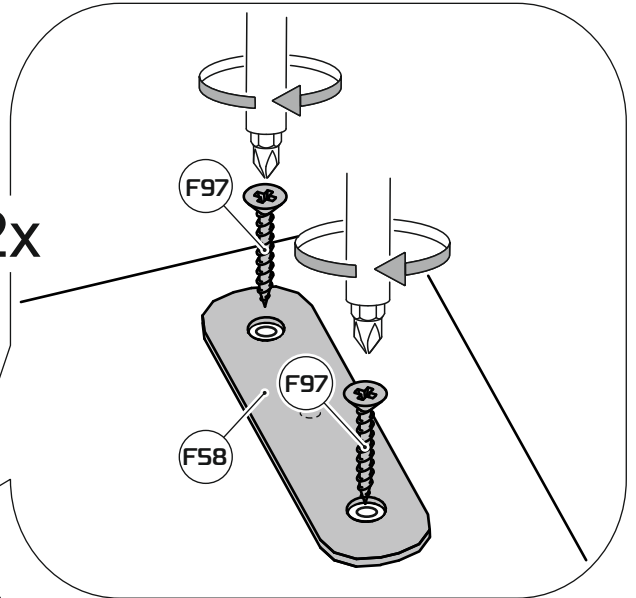

36



B

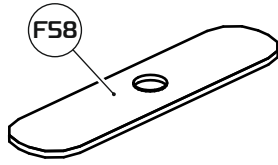

2x

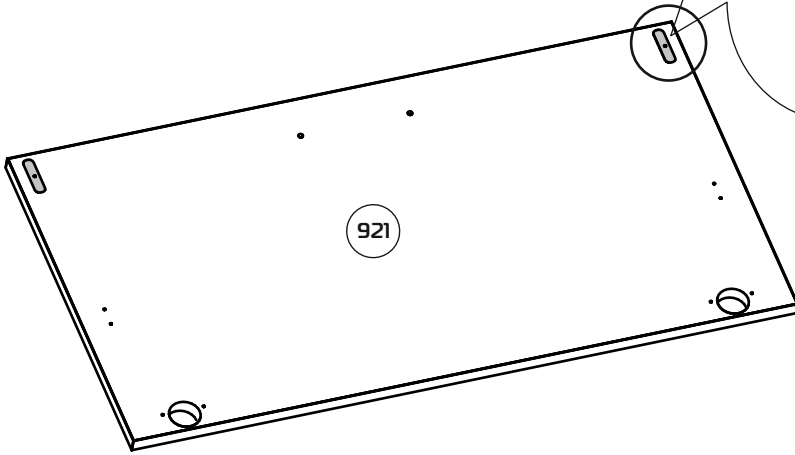
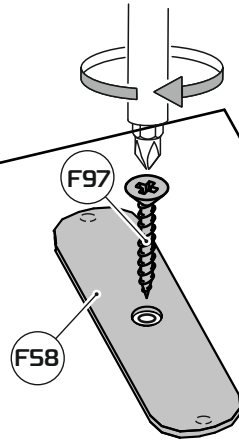

37

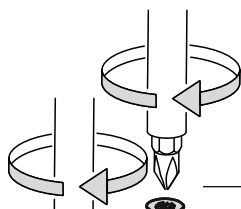

F201

F600

2x

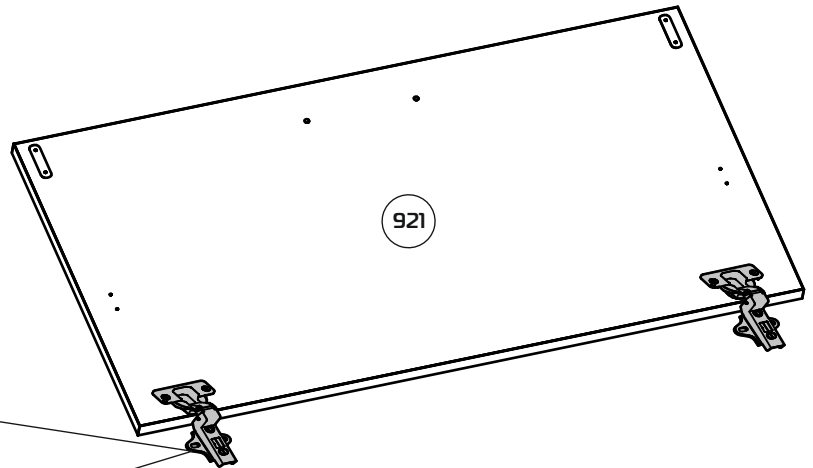

38

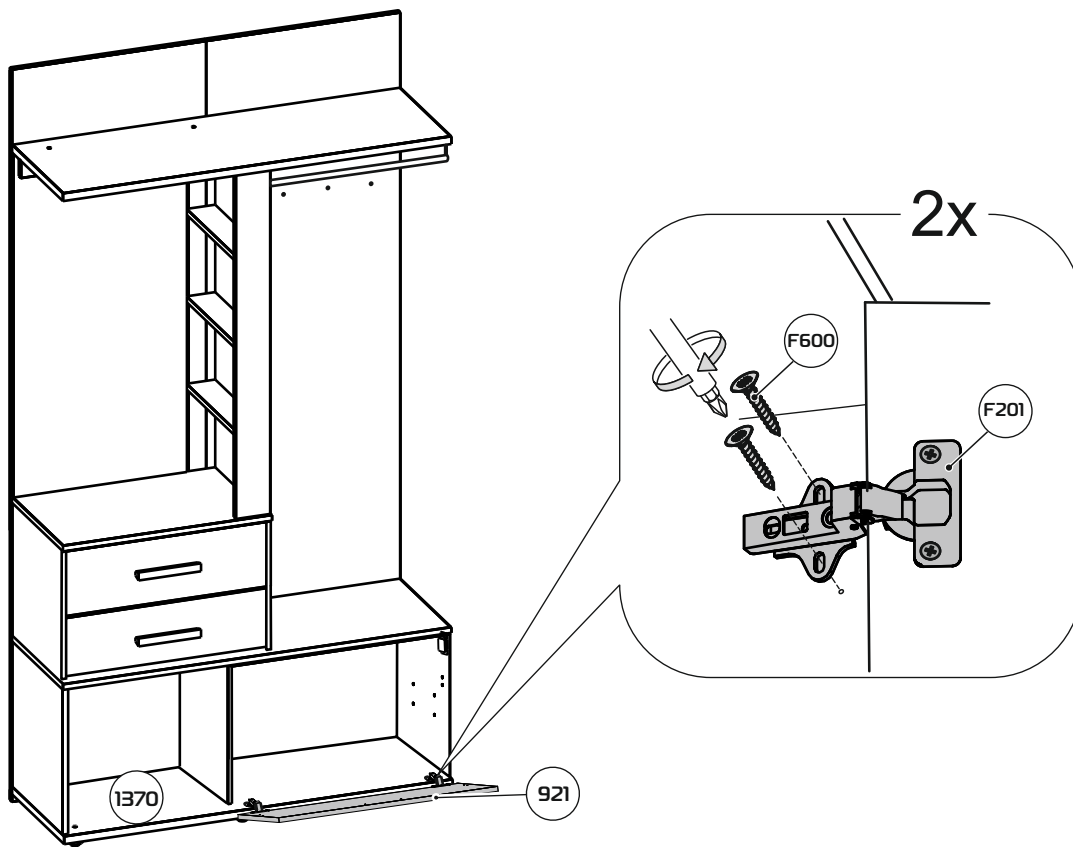

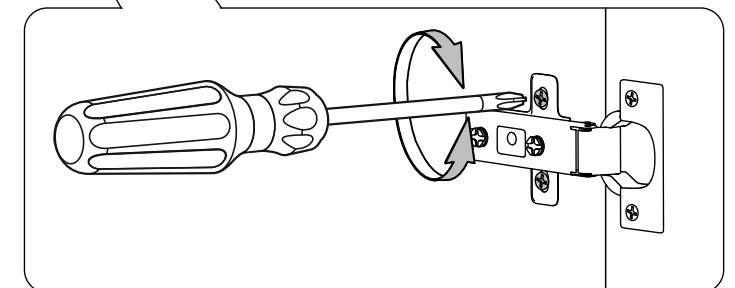
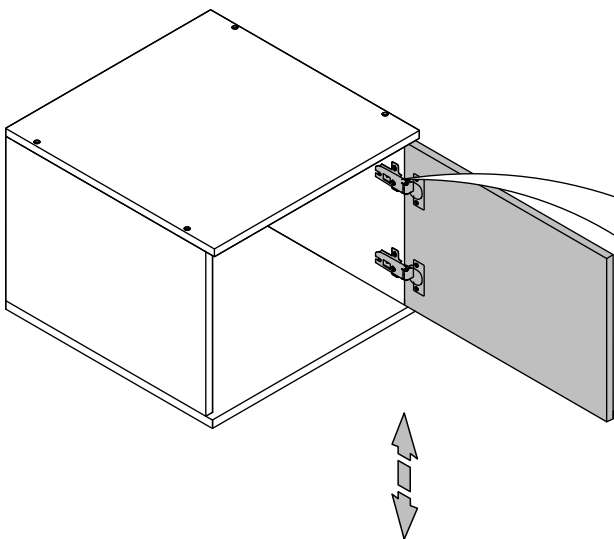
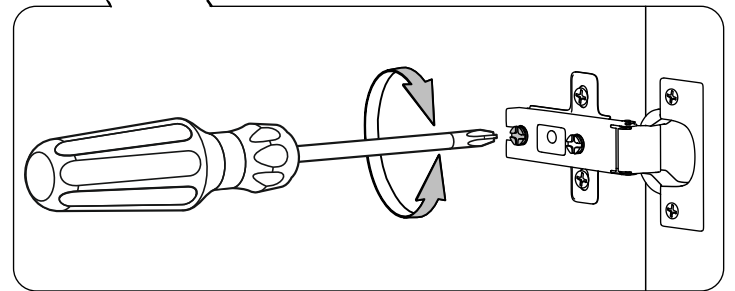
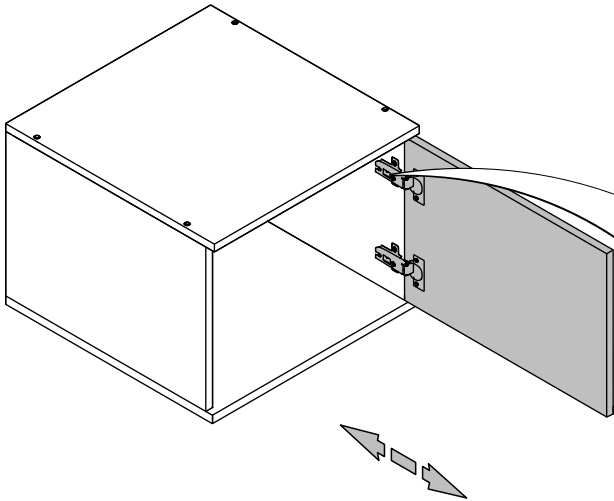
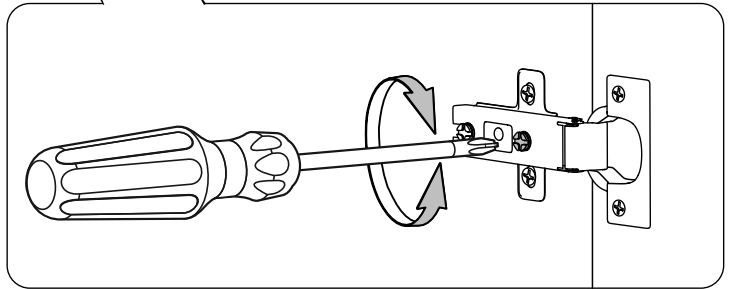
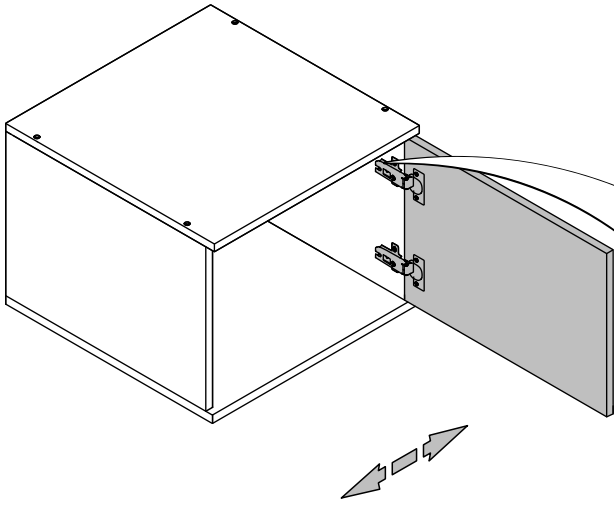

39

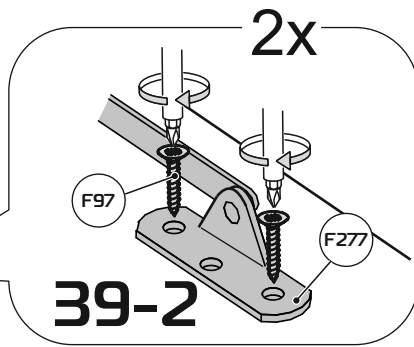
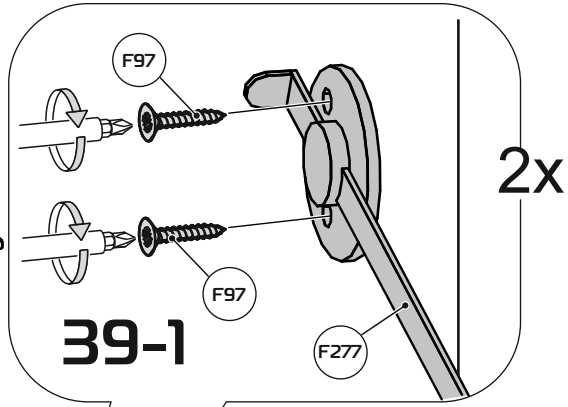
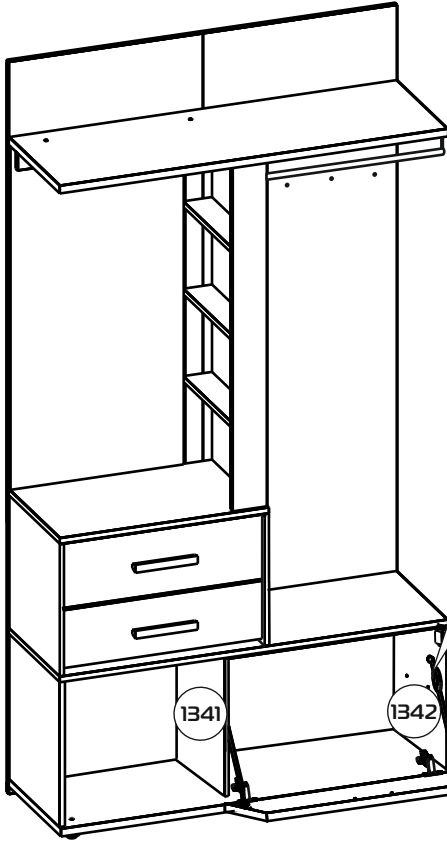

40

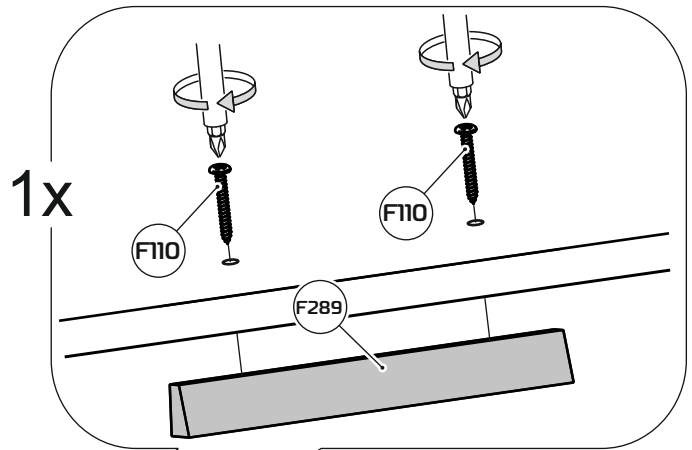
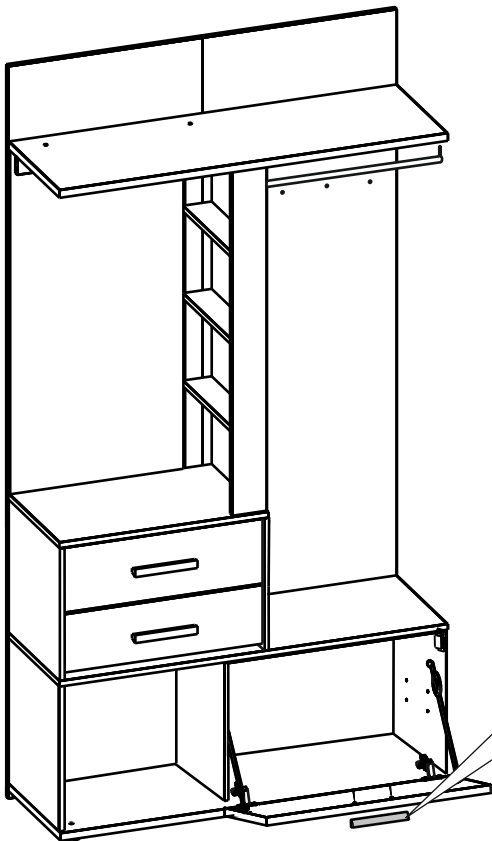

41

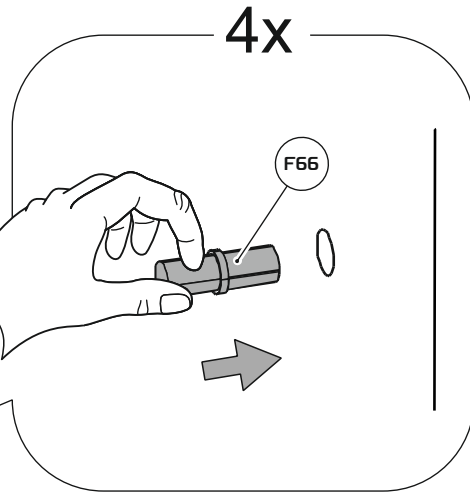
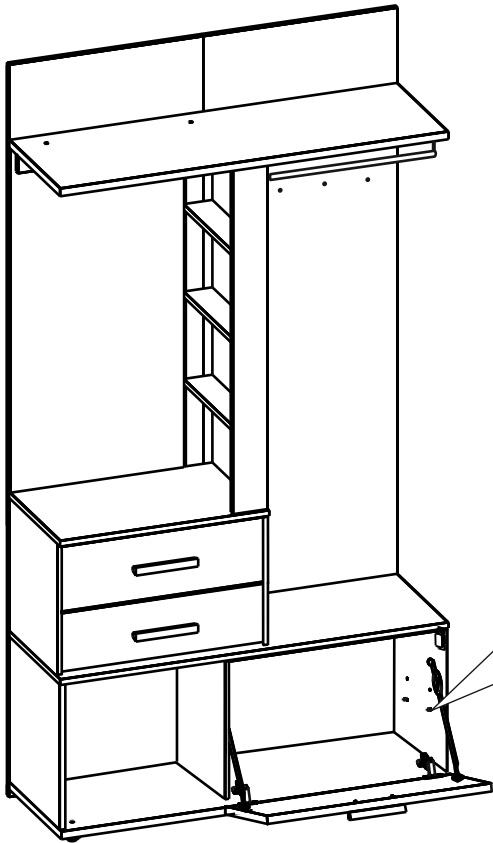

42

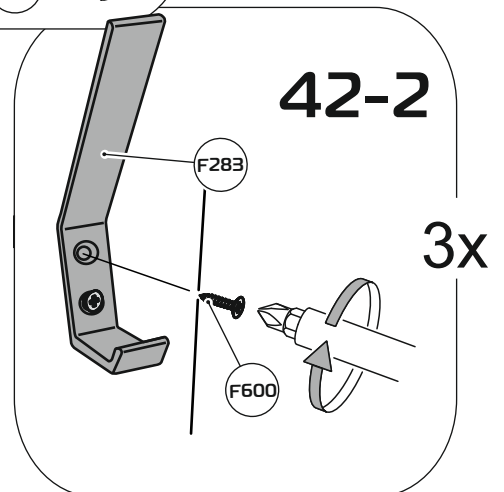
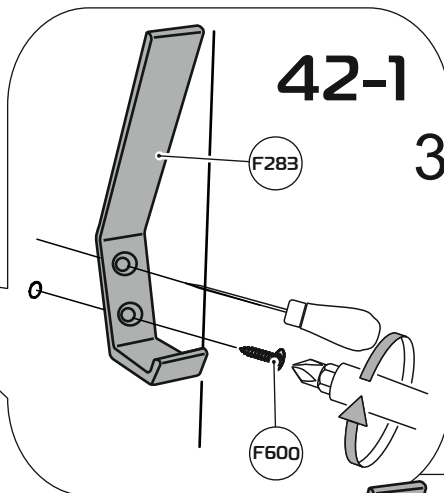
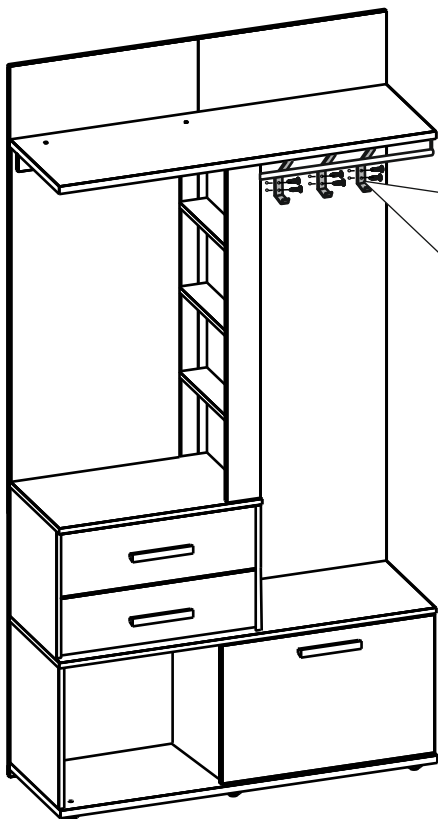

43

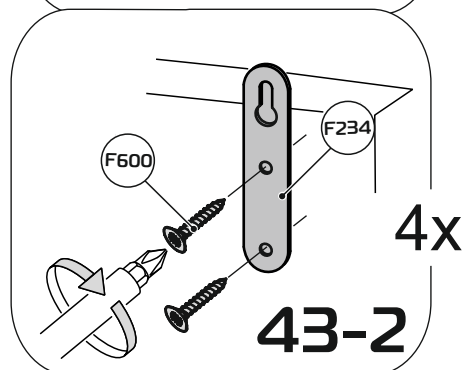
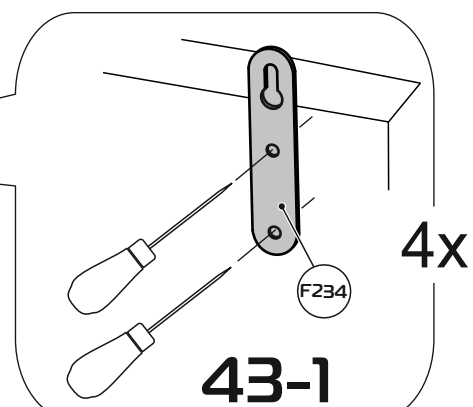
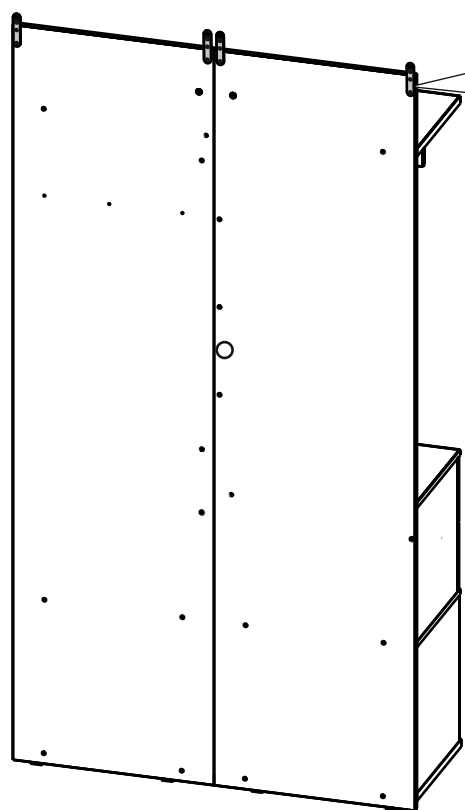

44

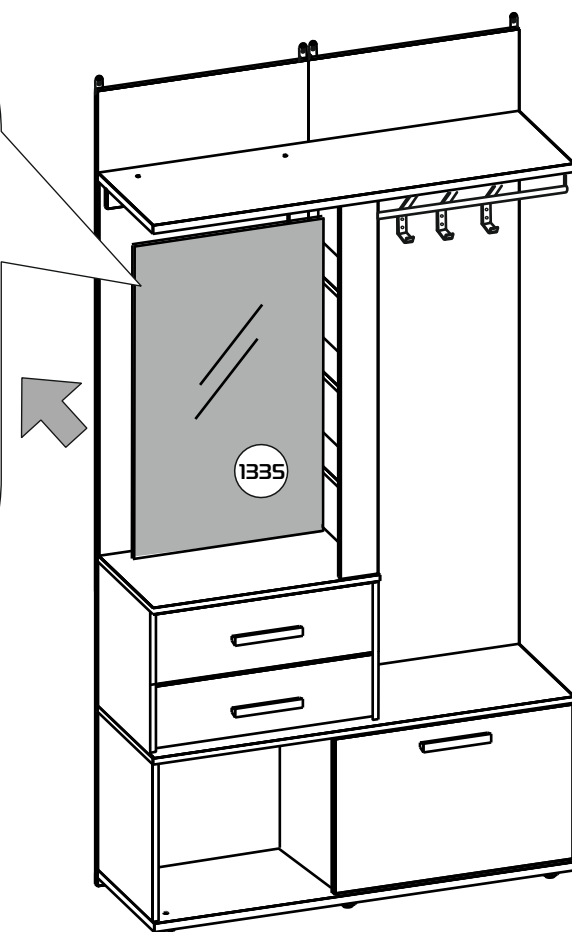
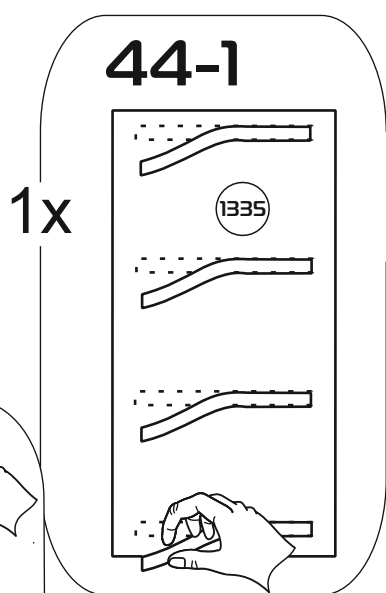
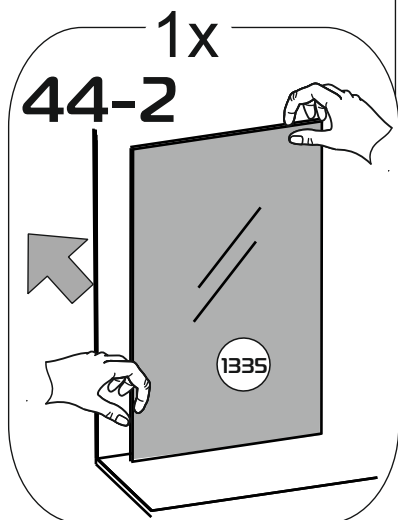

45

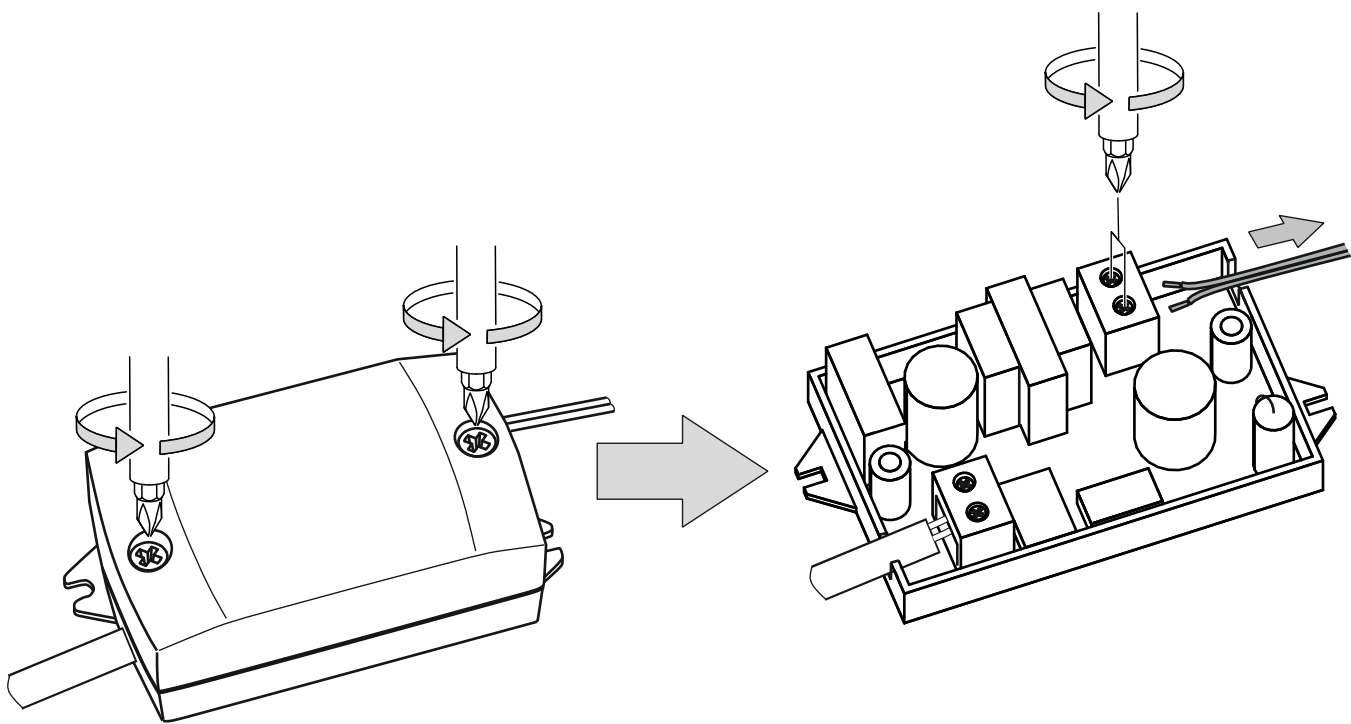

46

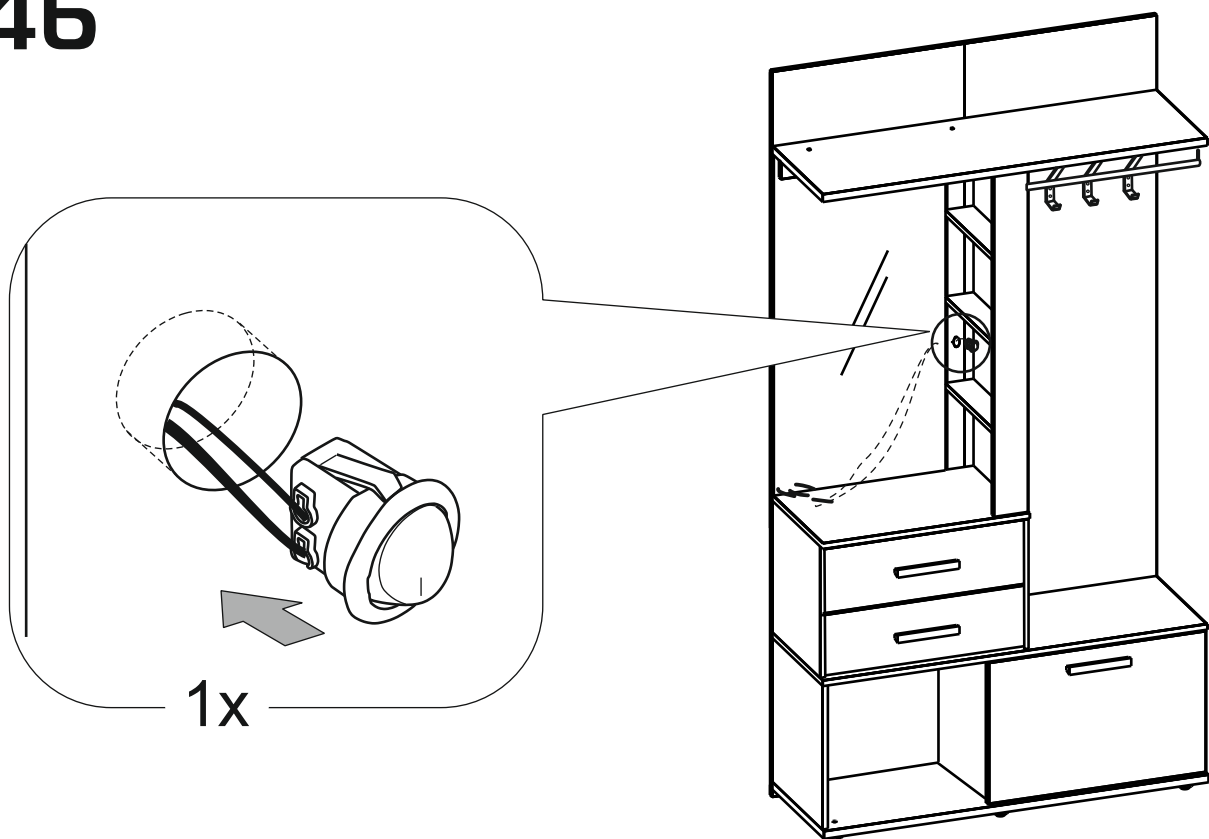

47

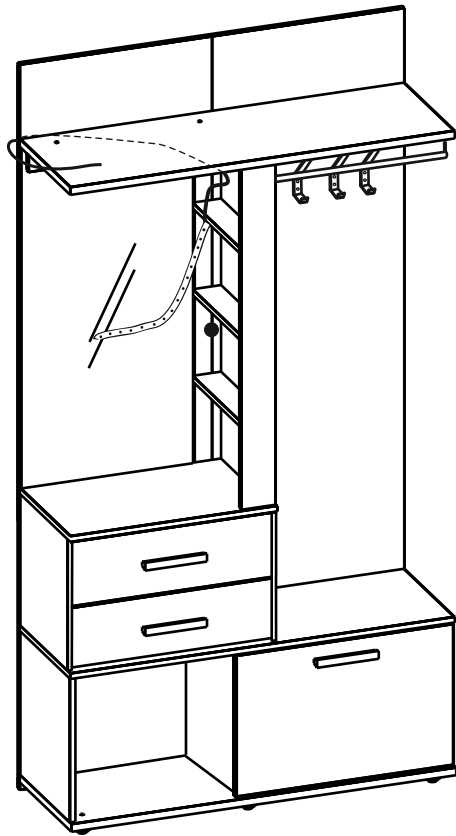

48

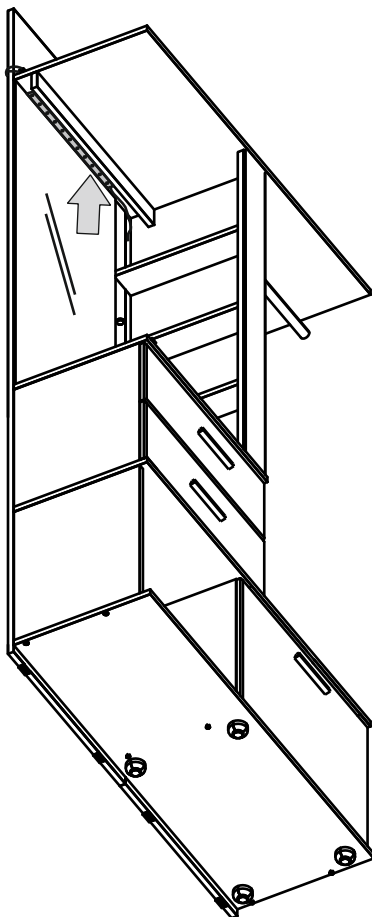

1x

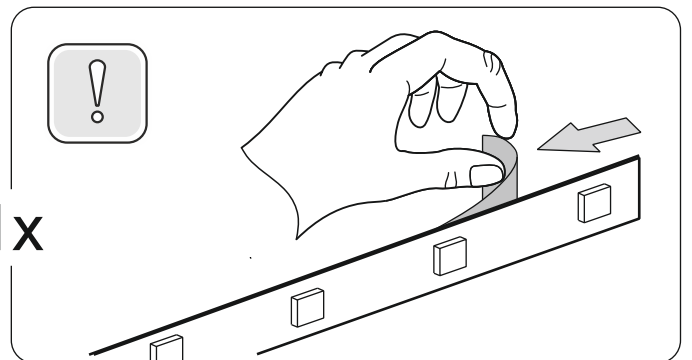

49

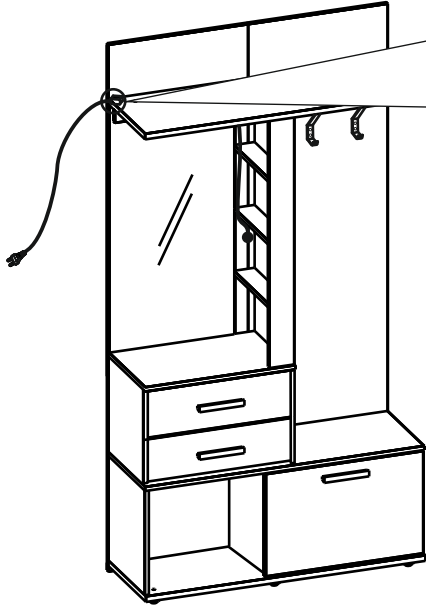
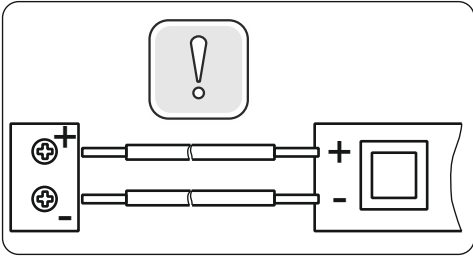

49-1

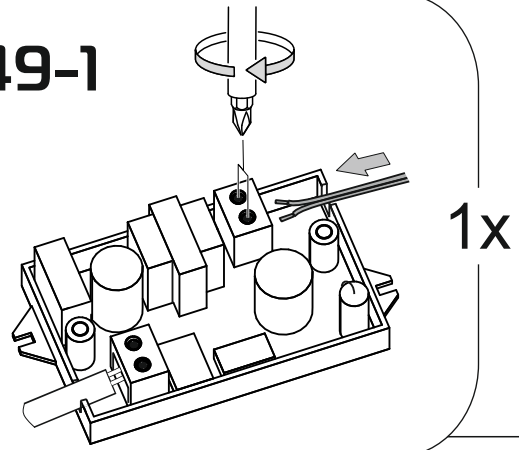

49-2

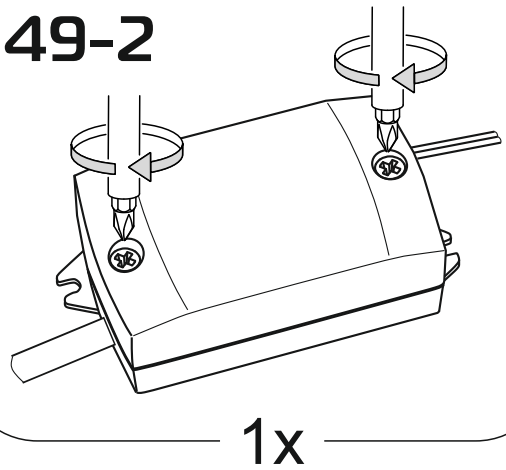

50

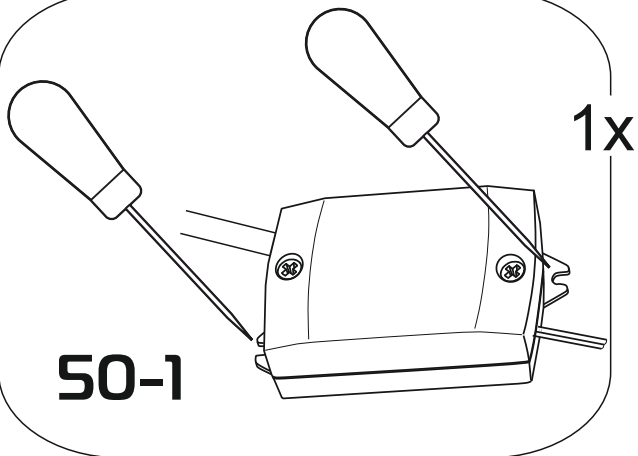
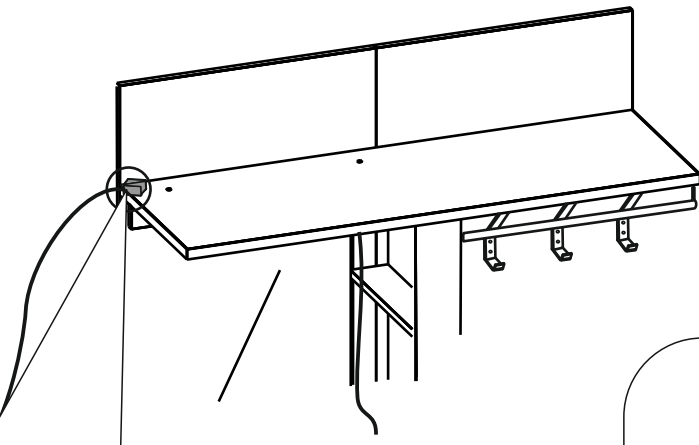

50-2

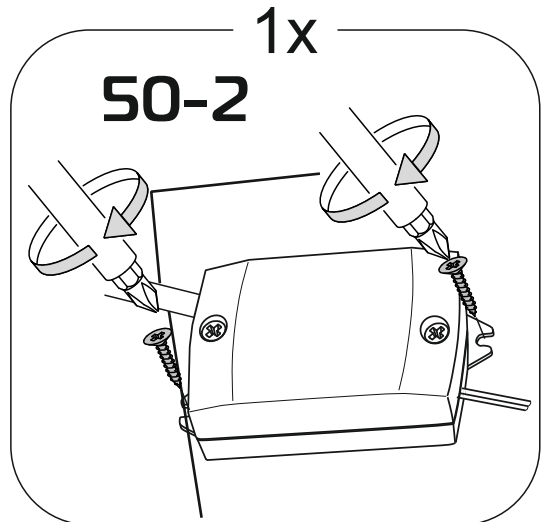

51

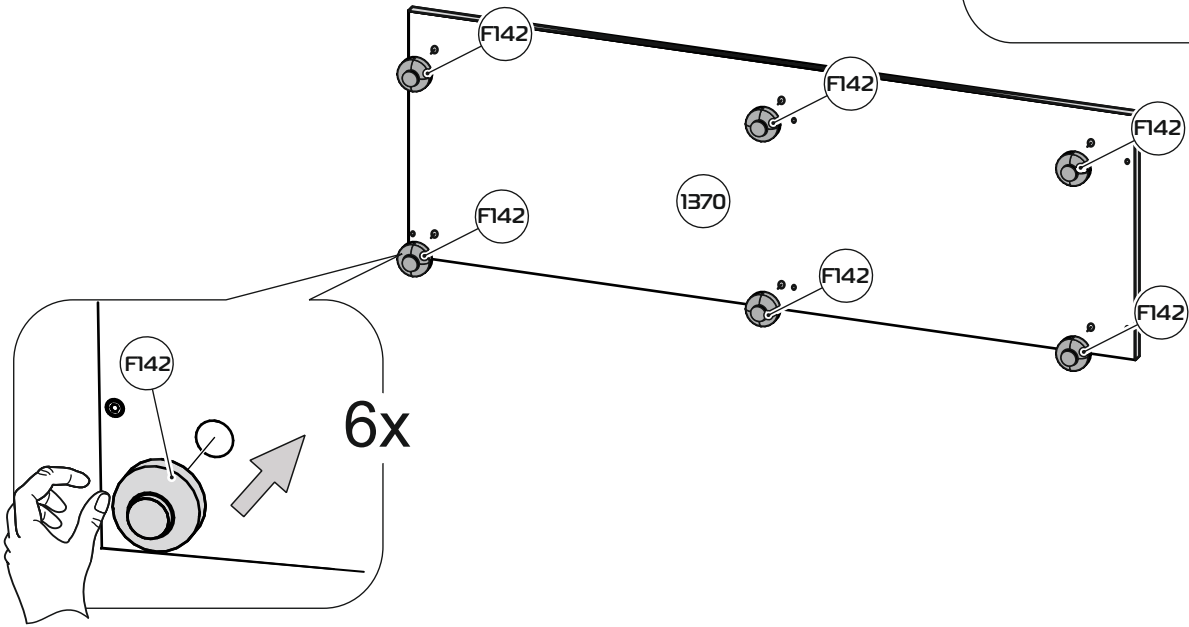
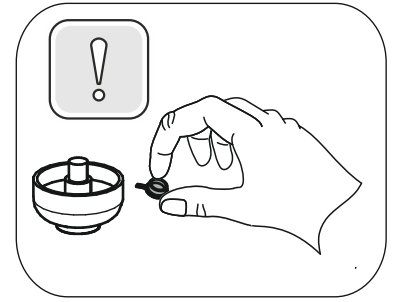

52

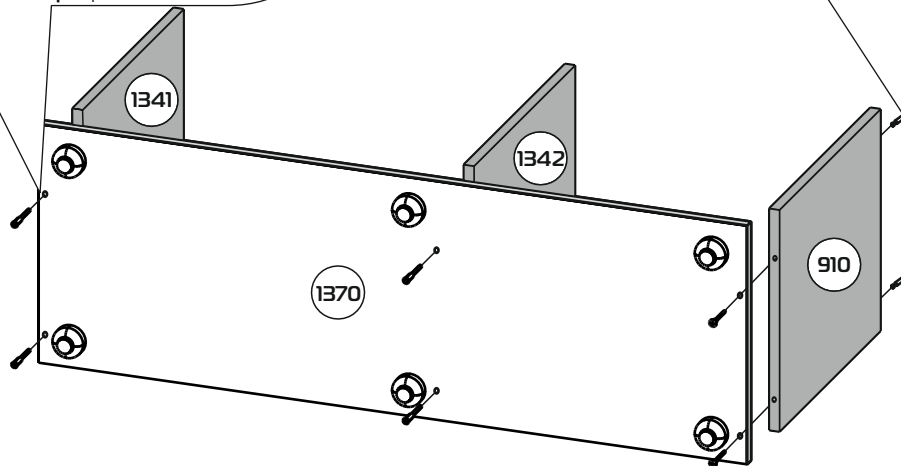
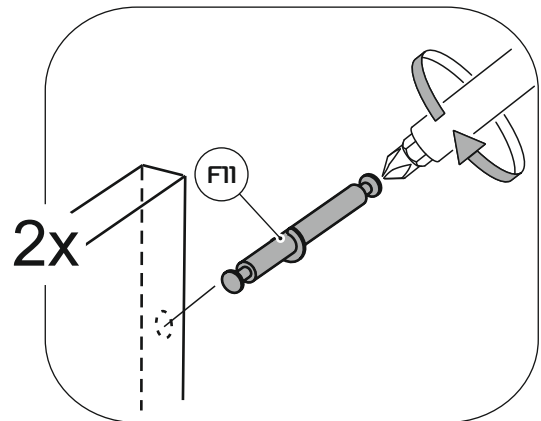
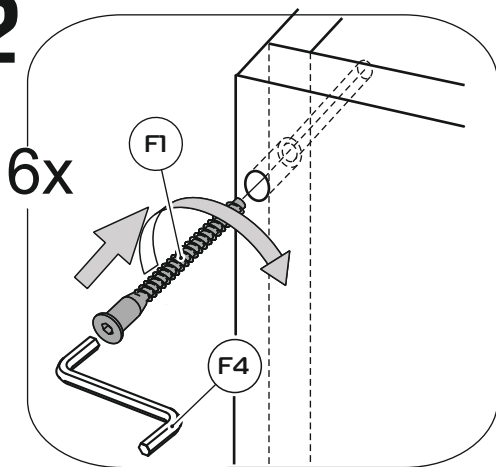

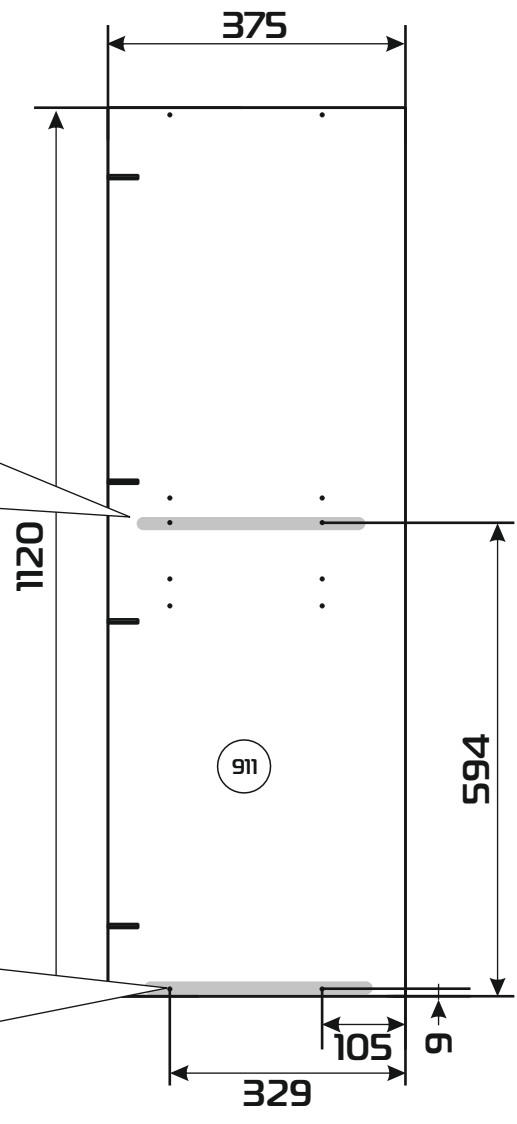
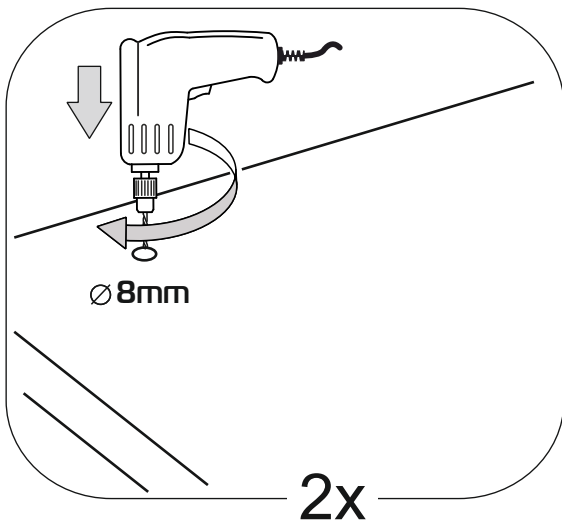
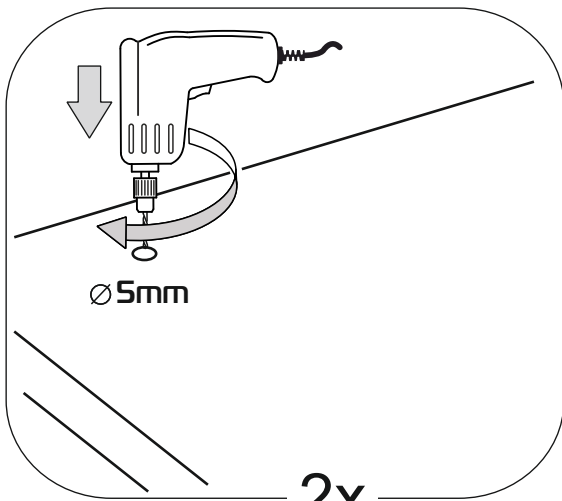
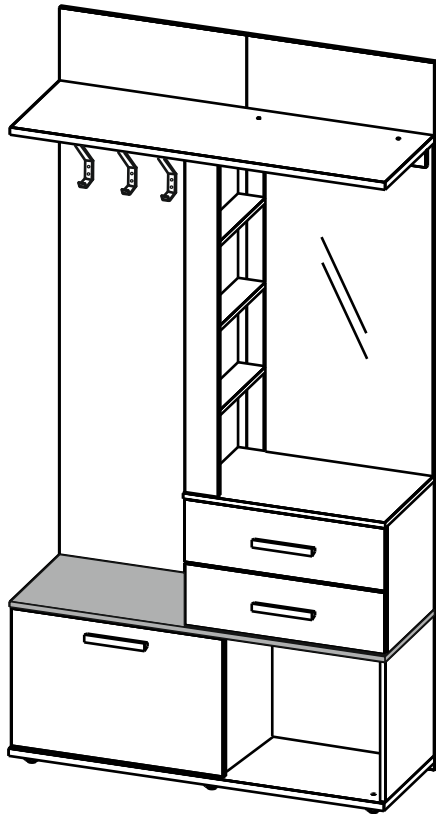

53

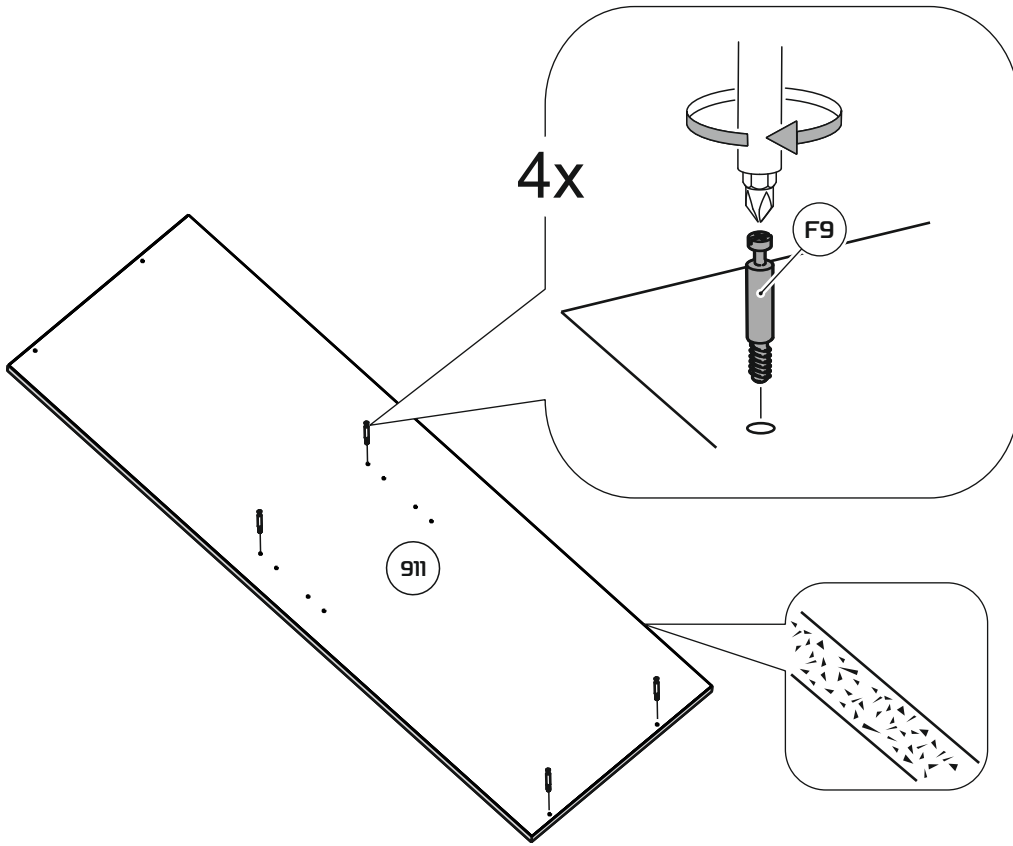

54

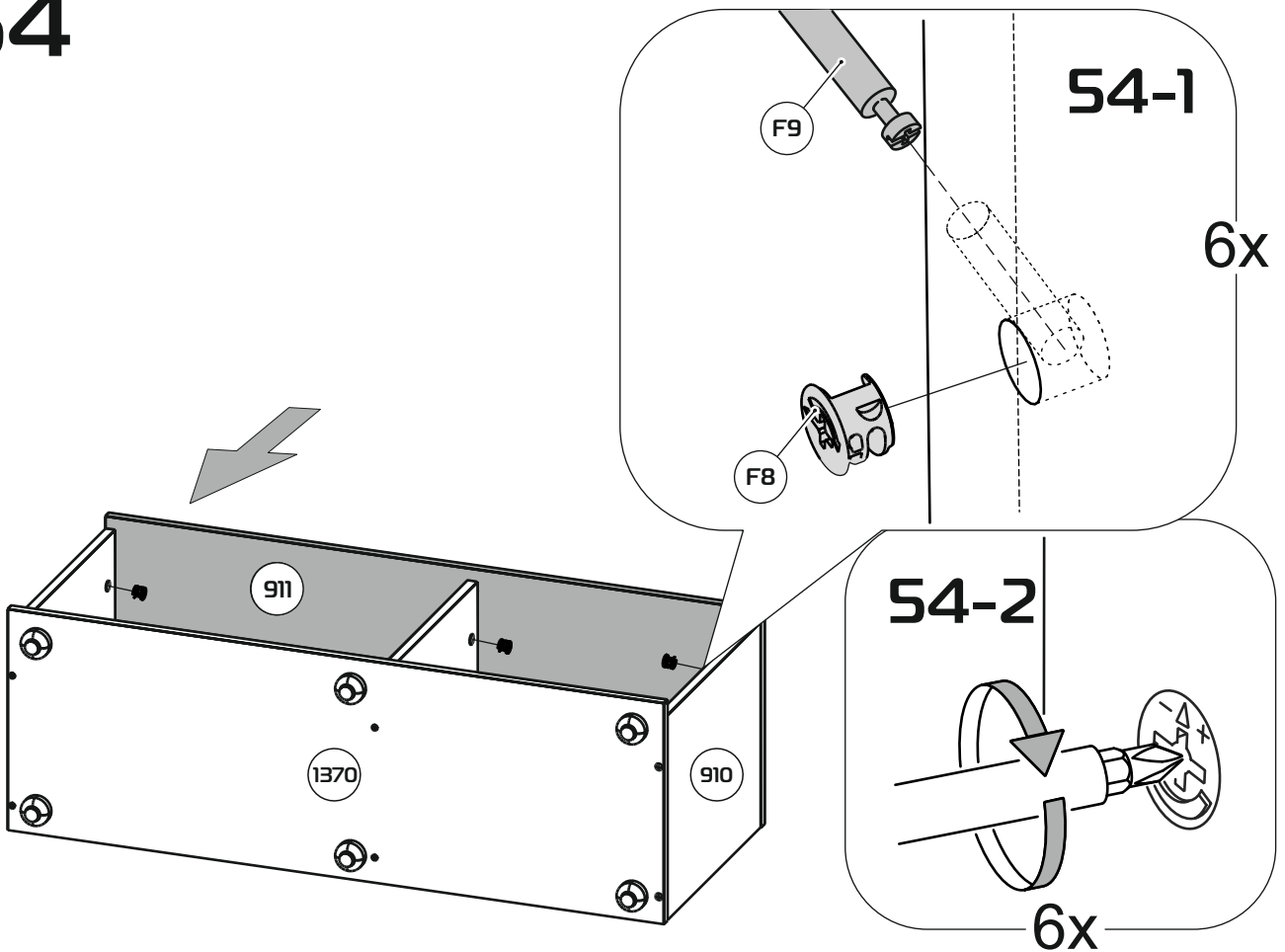

55

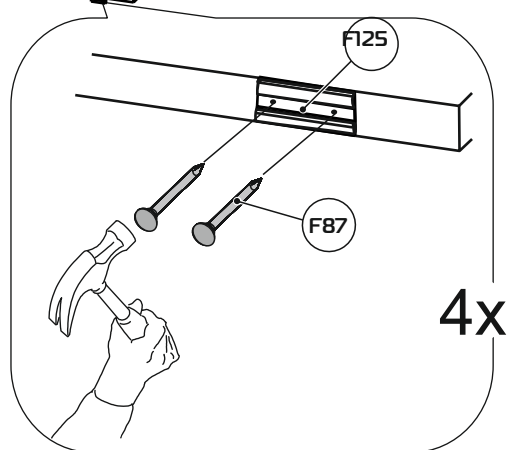
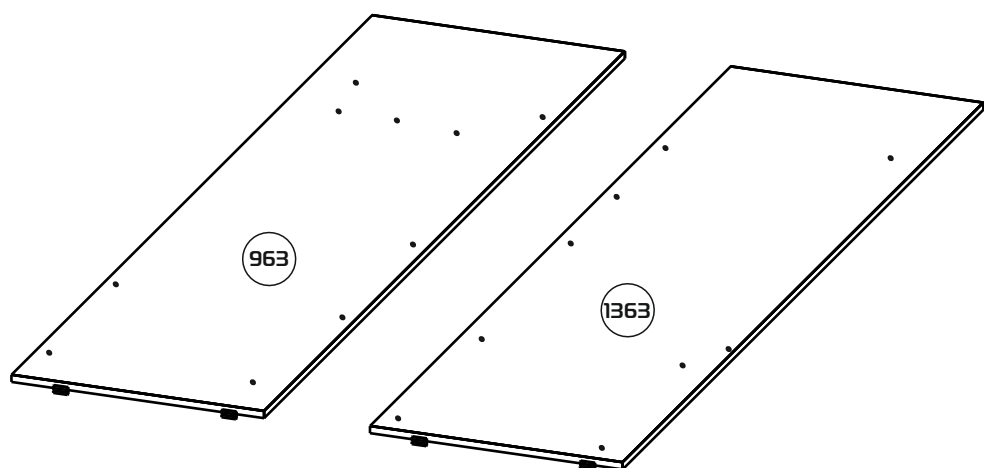

56

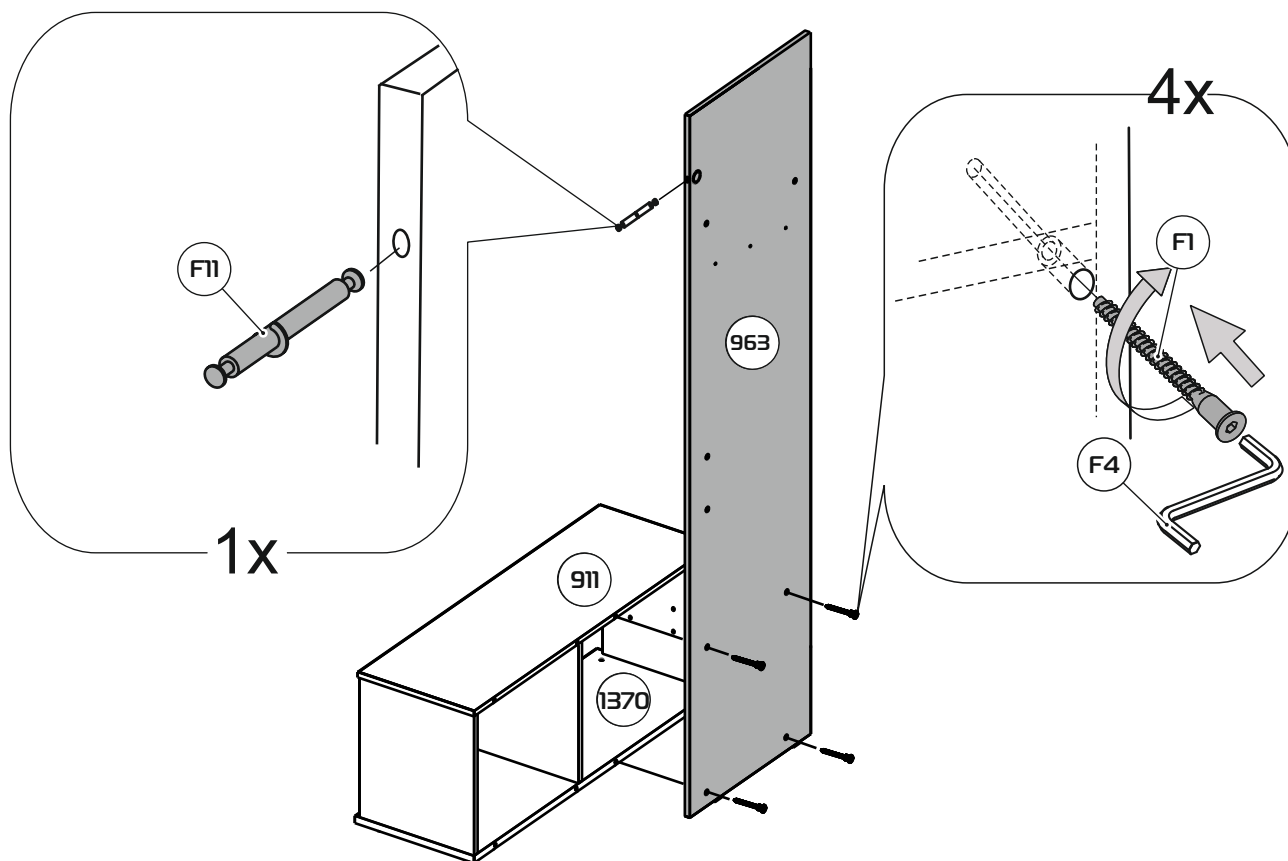

57

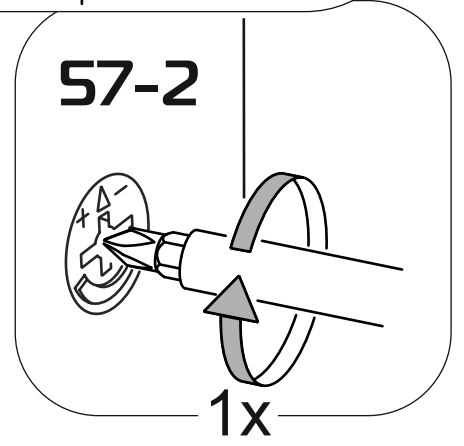
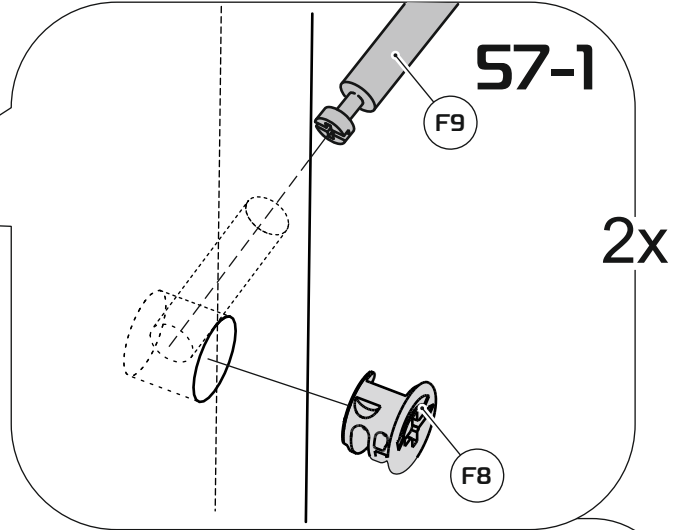
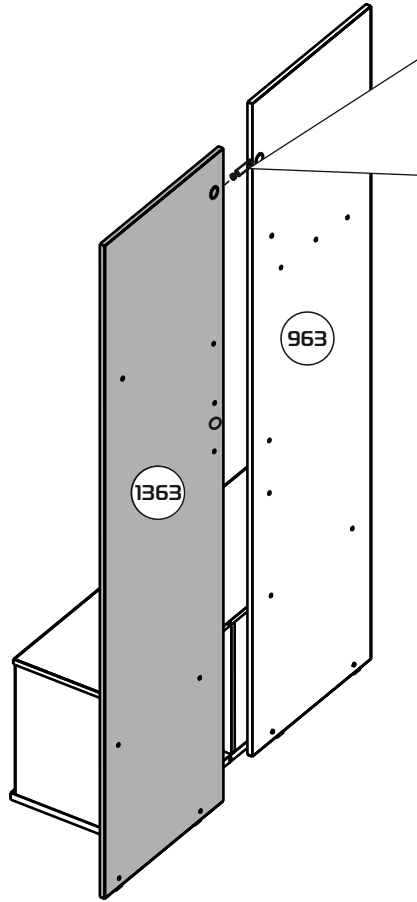

58

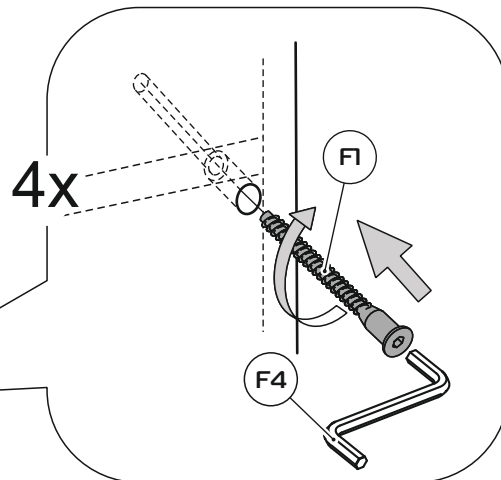
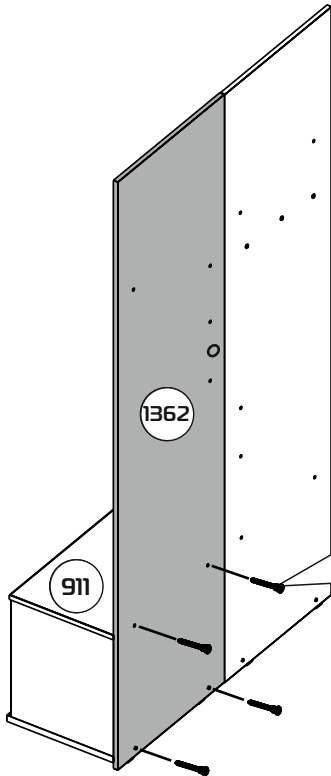

59

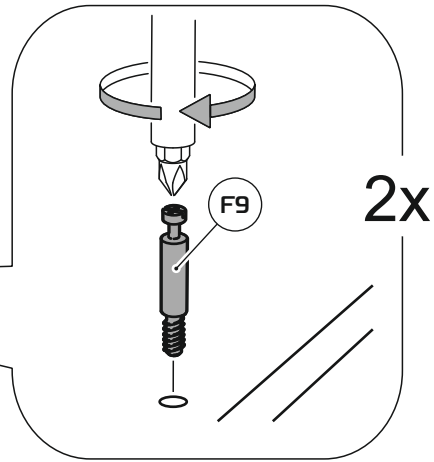
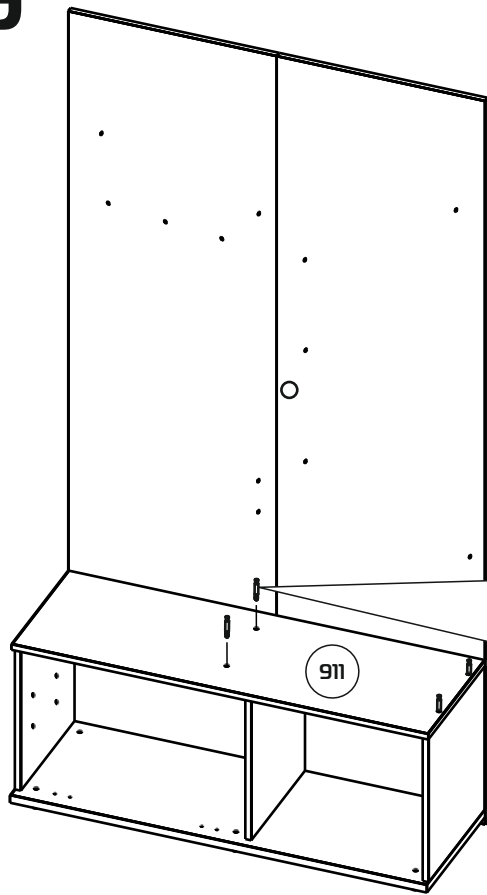

59

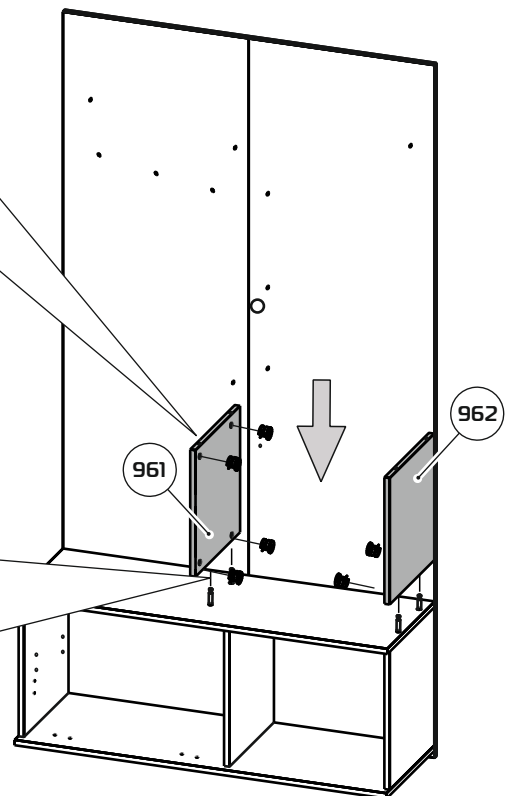
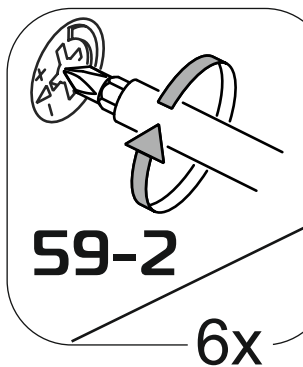
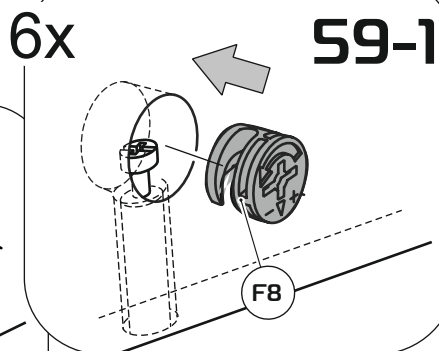
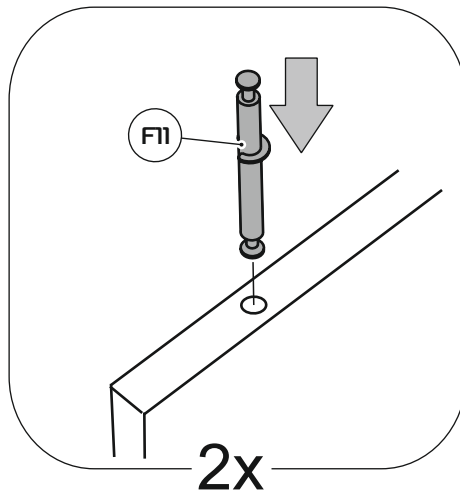

60

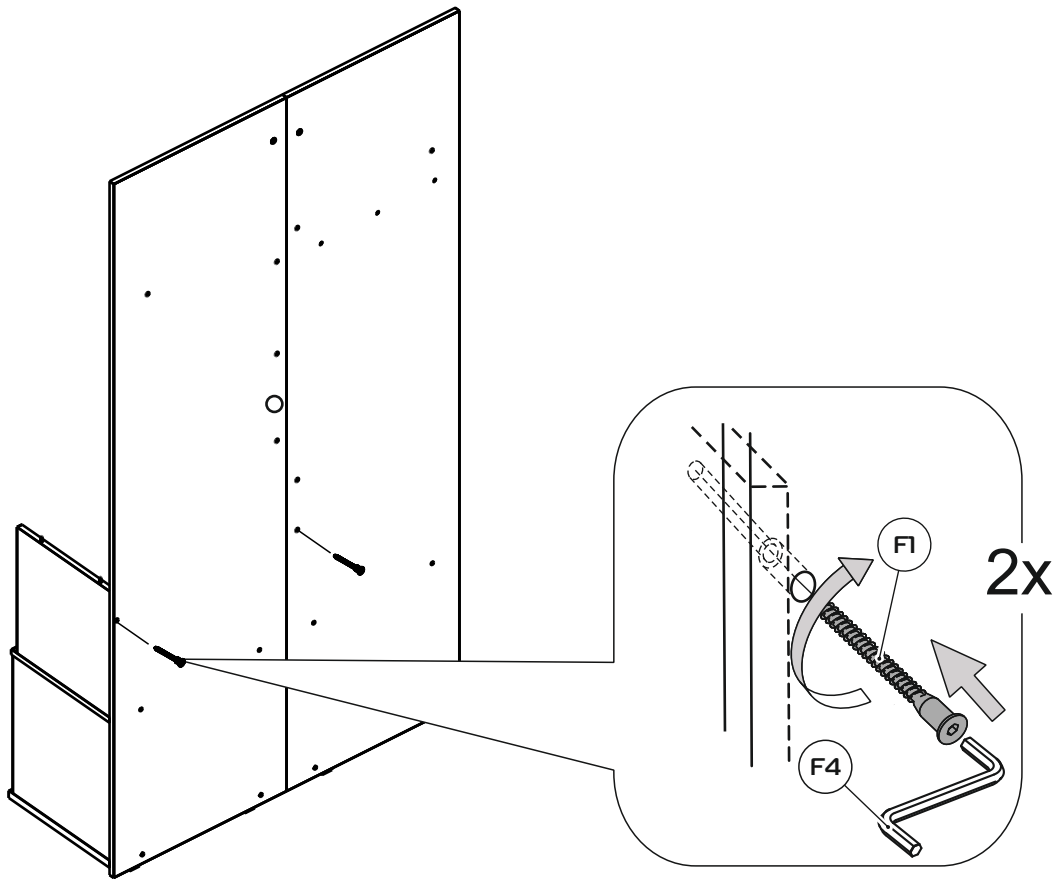

61

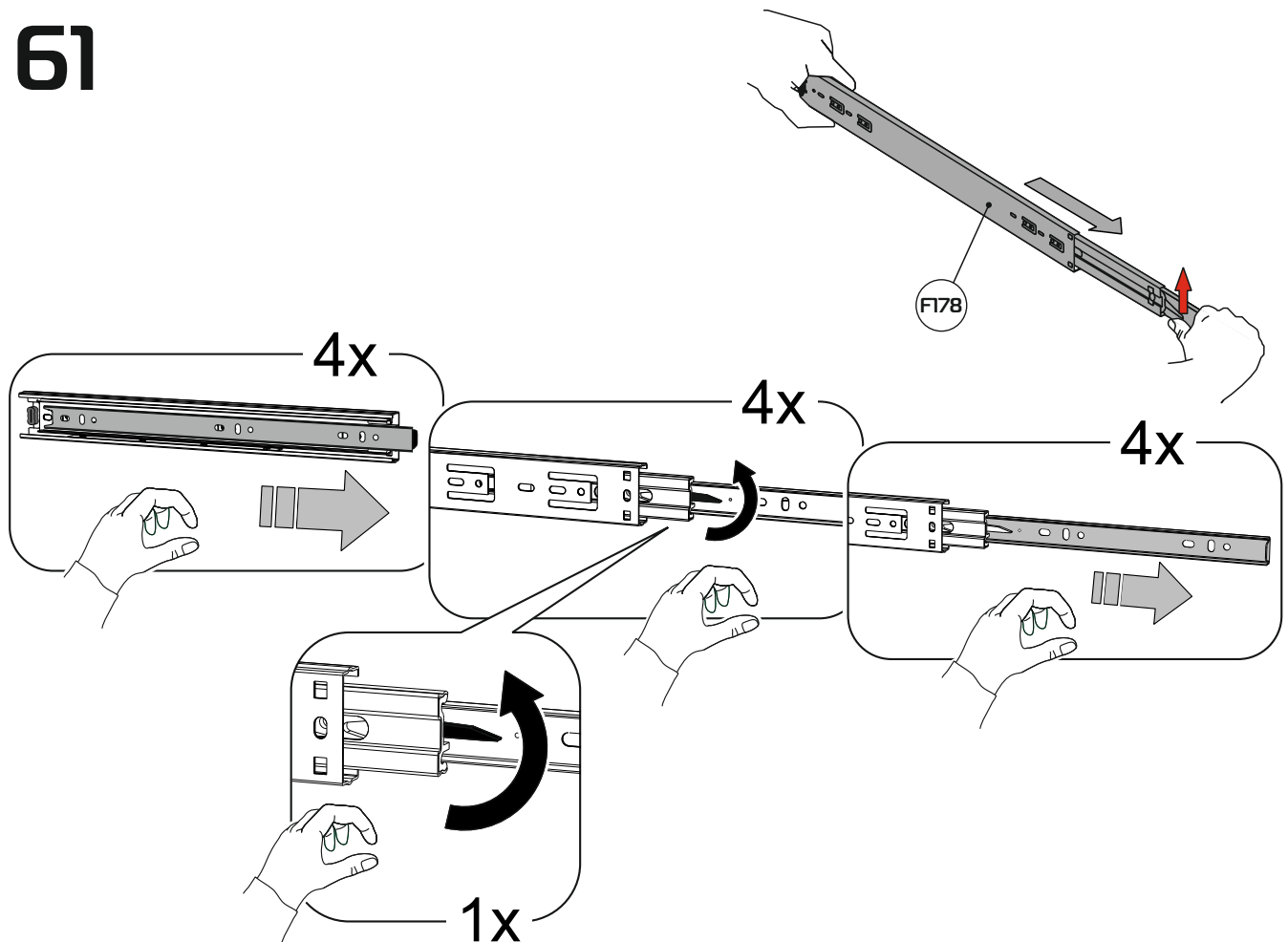

62

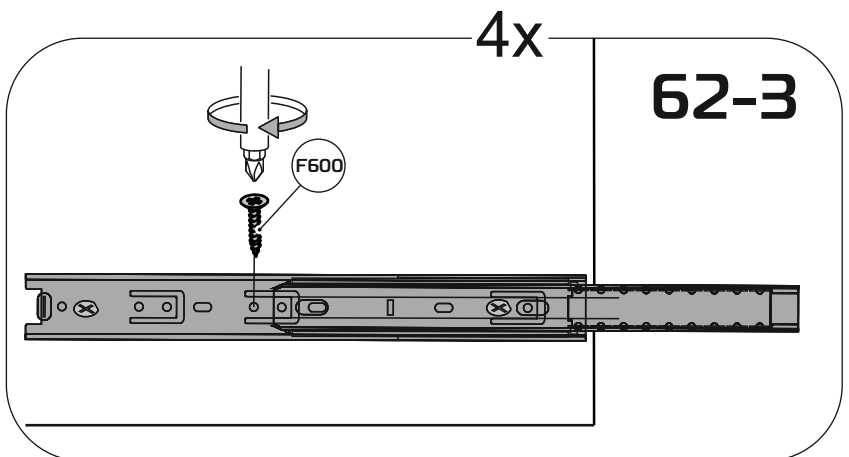
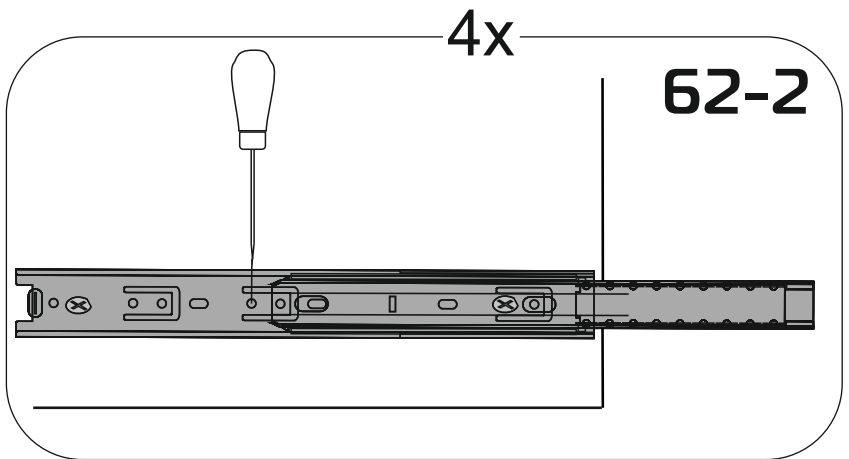
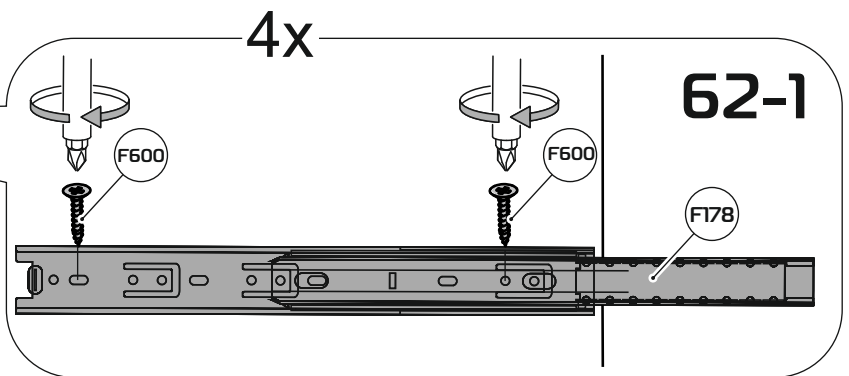
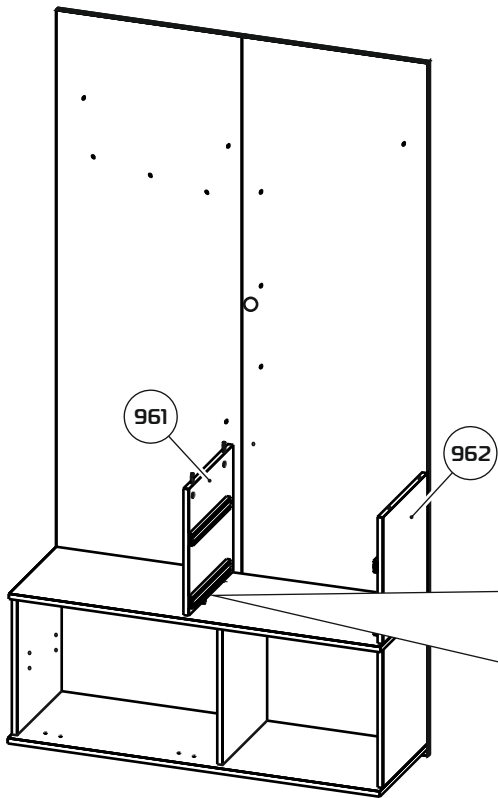

63

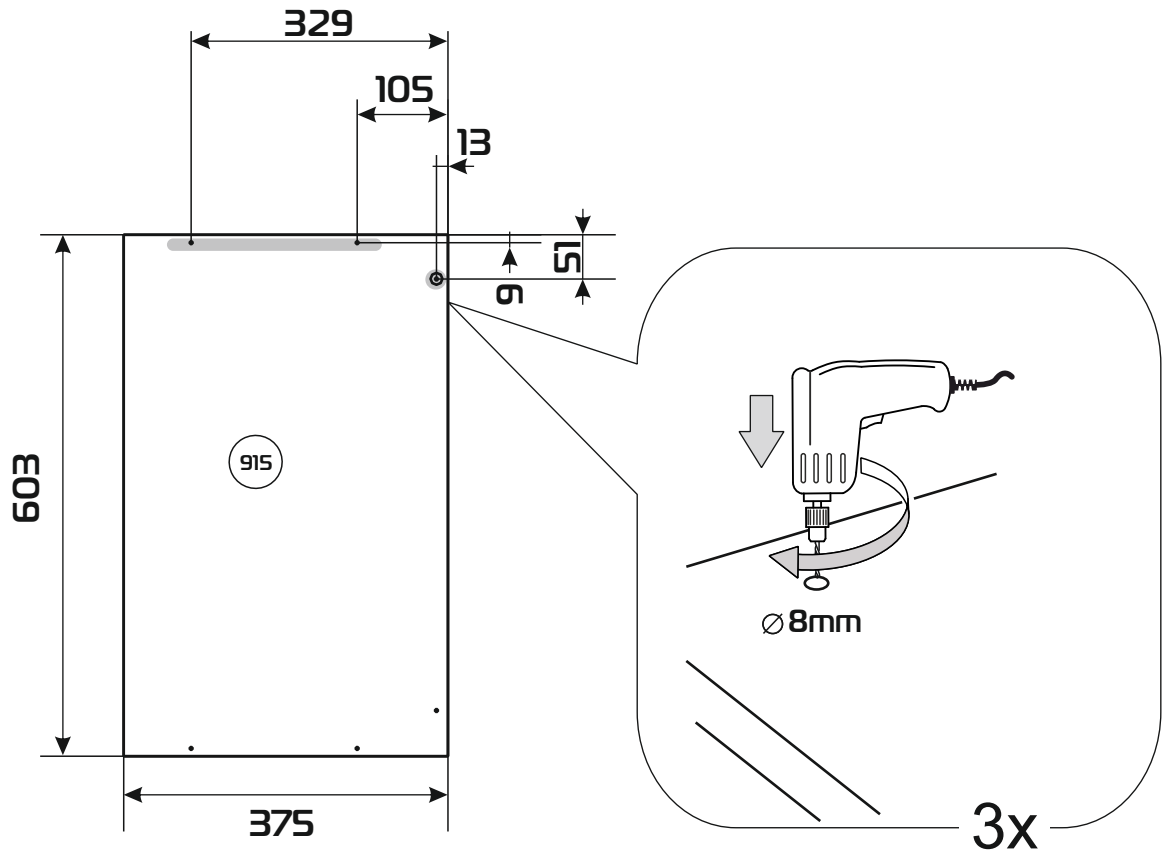

64

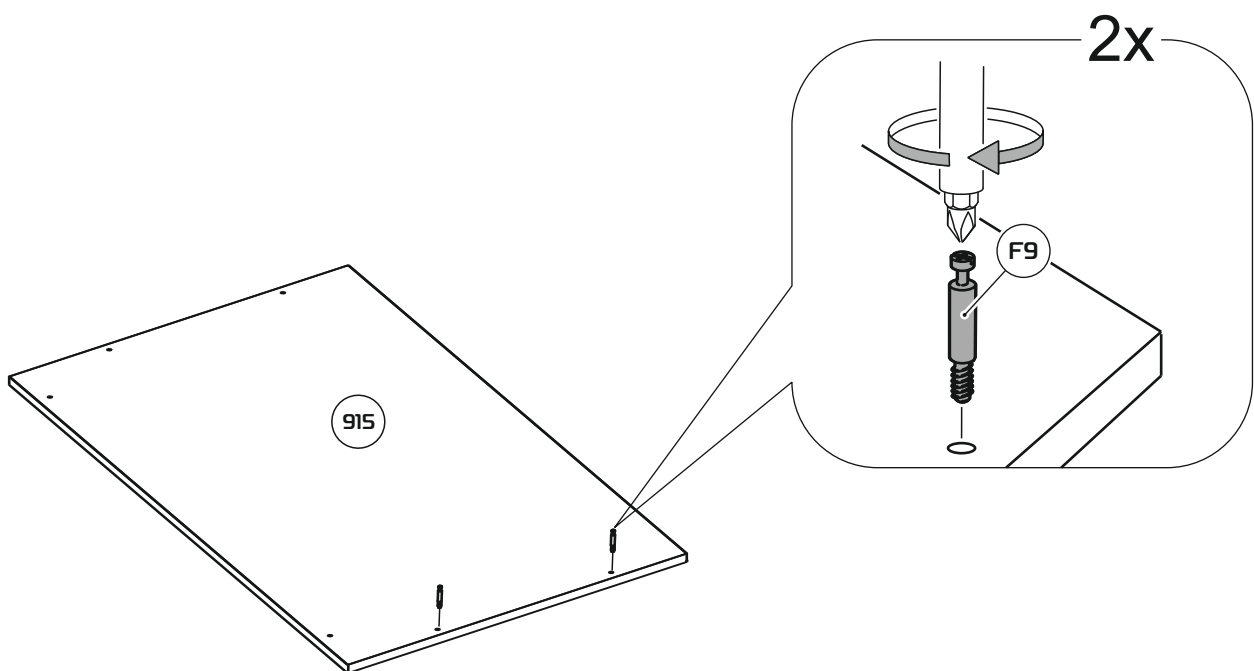

65

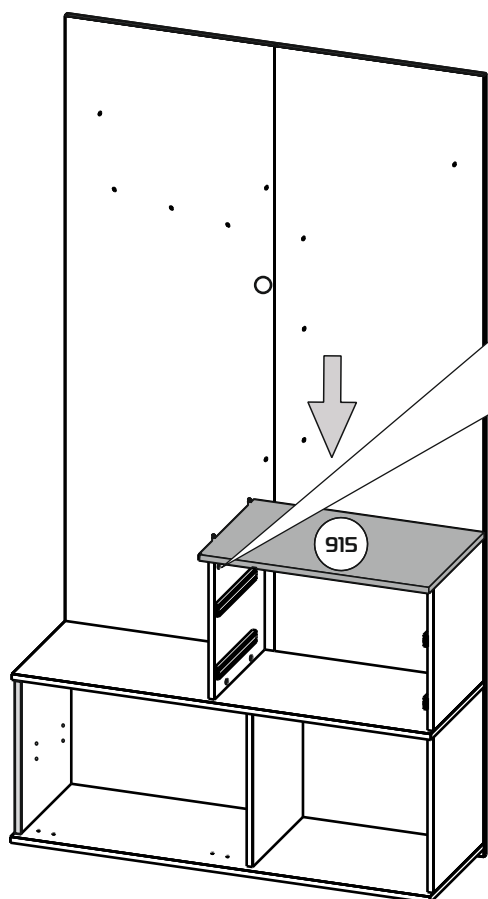

65-1

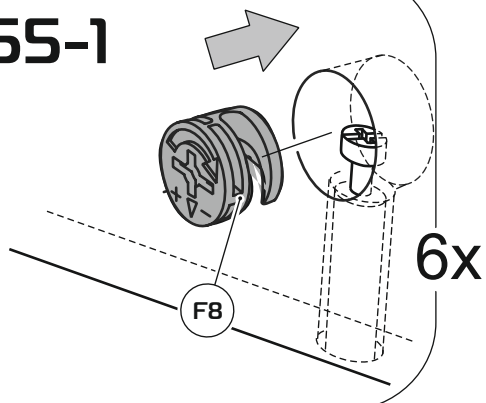

6x

65-2

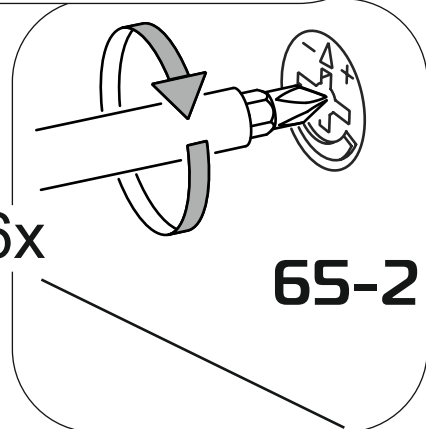

66

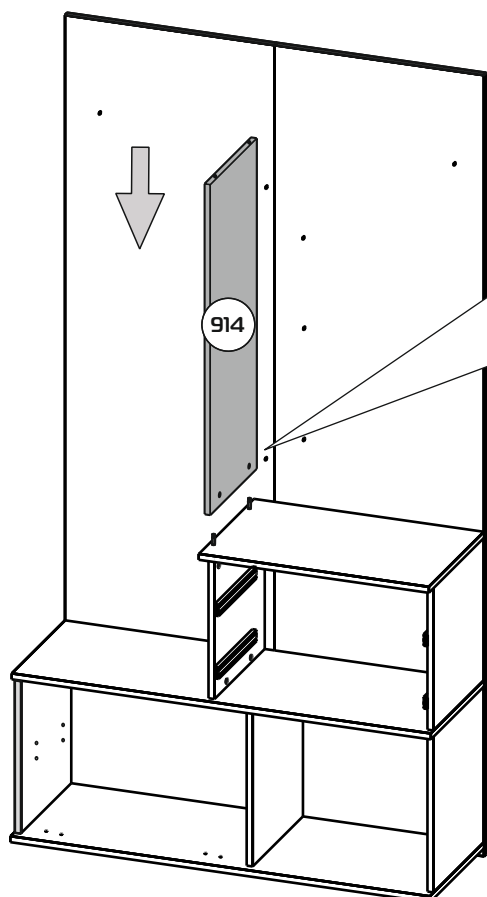

66-1

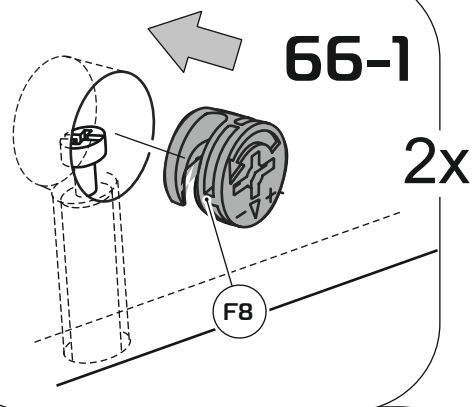

2x

66-2

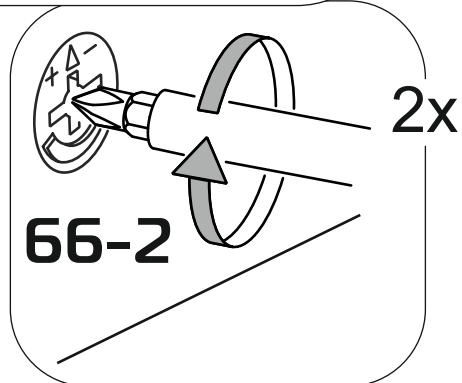

2x

67

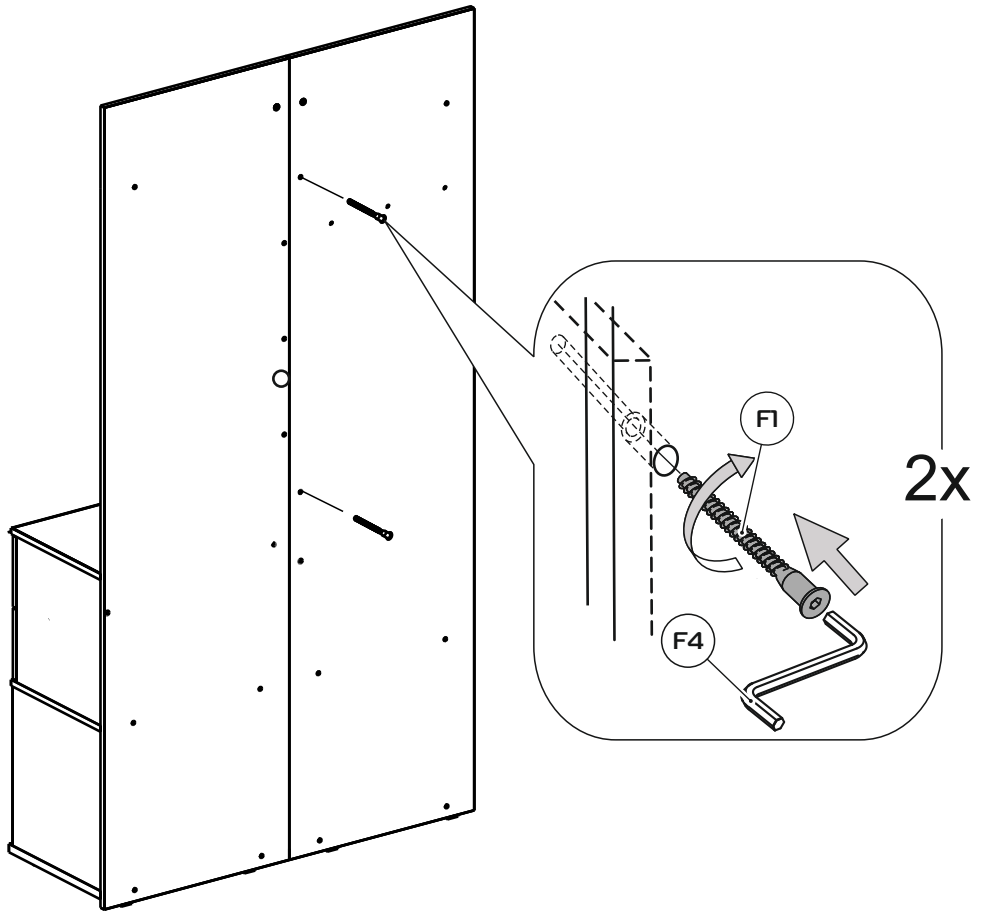

68

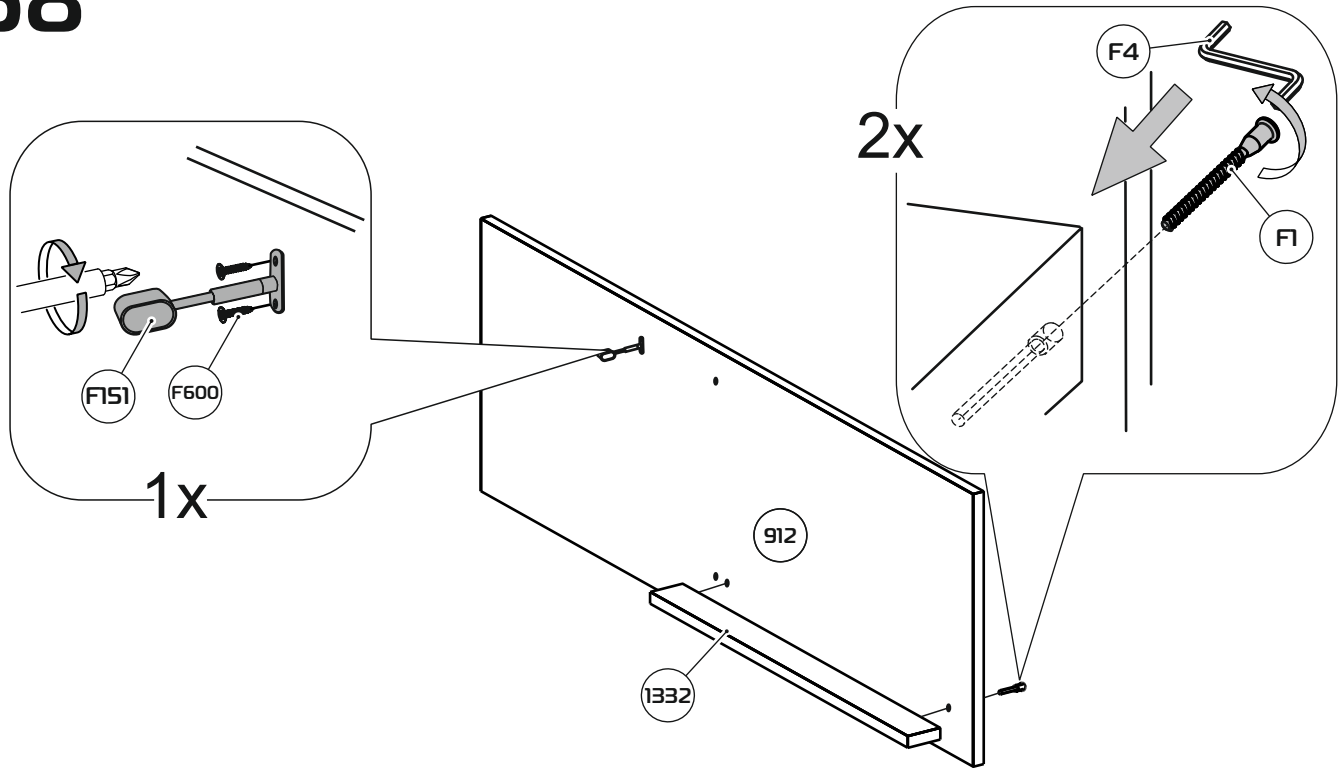

69

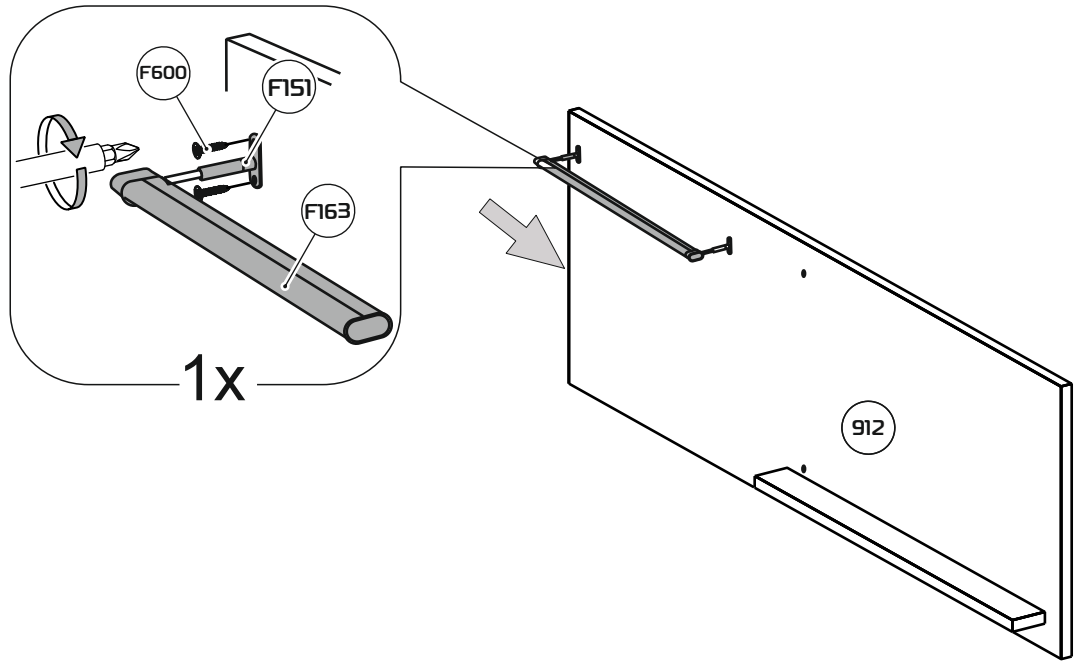

70

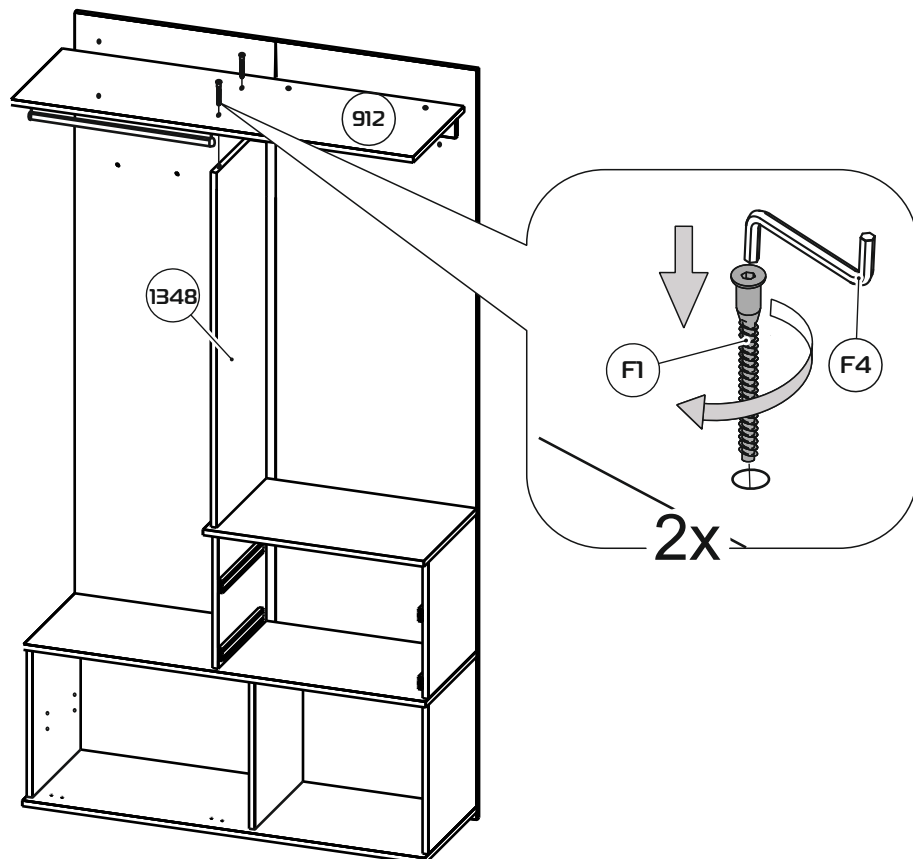

71

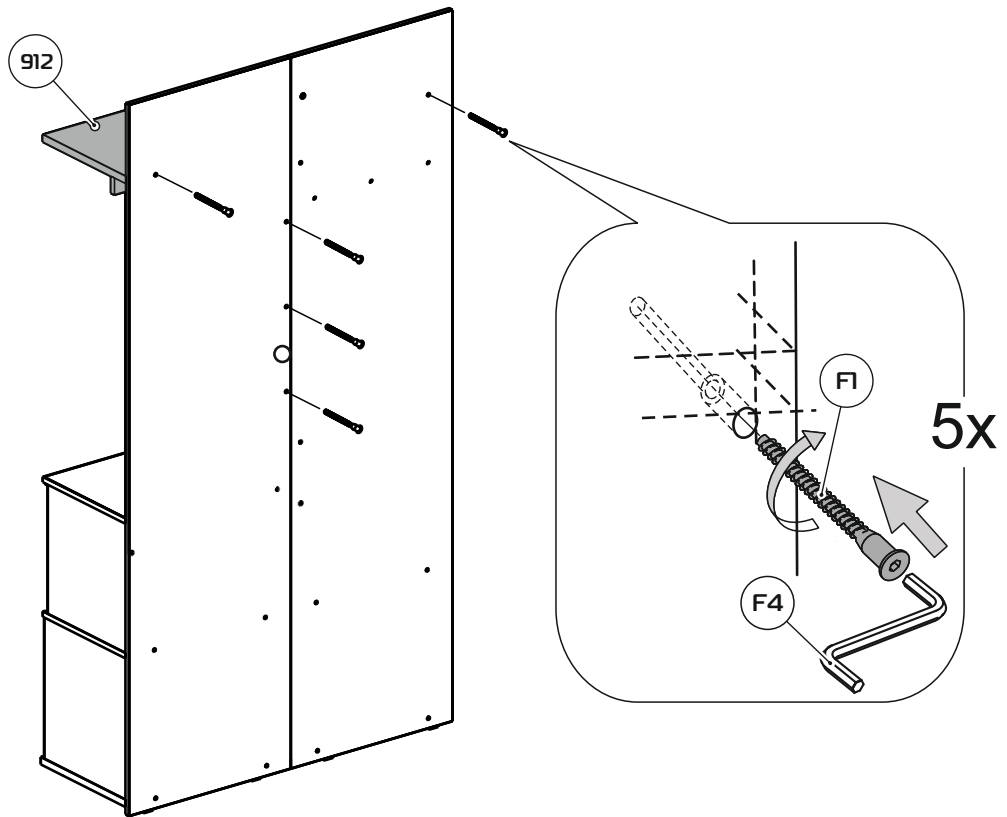

72

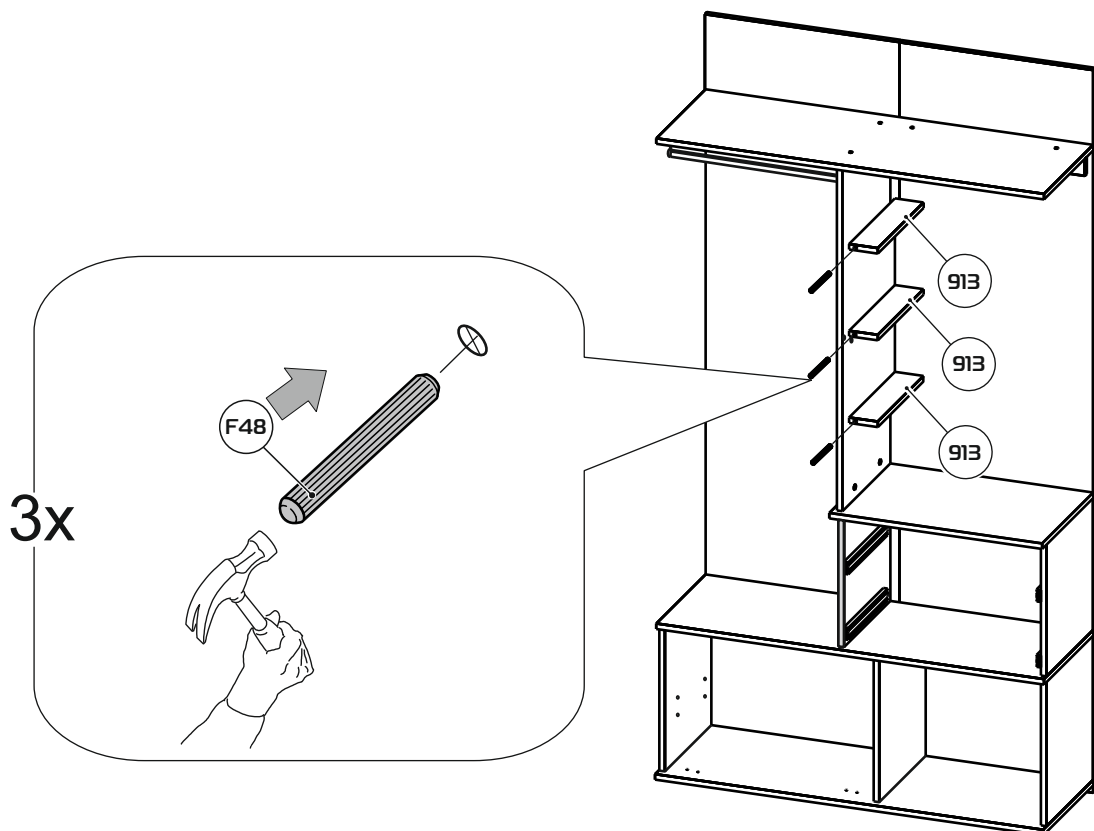

73

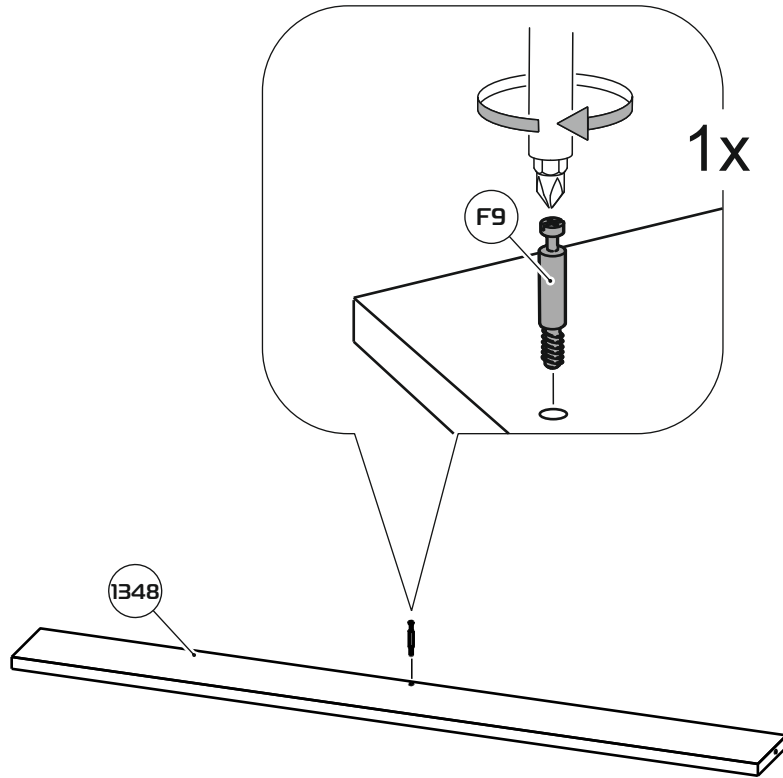

74

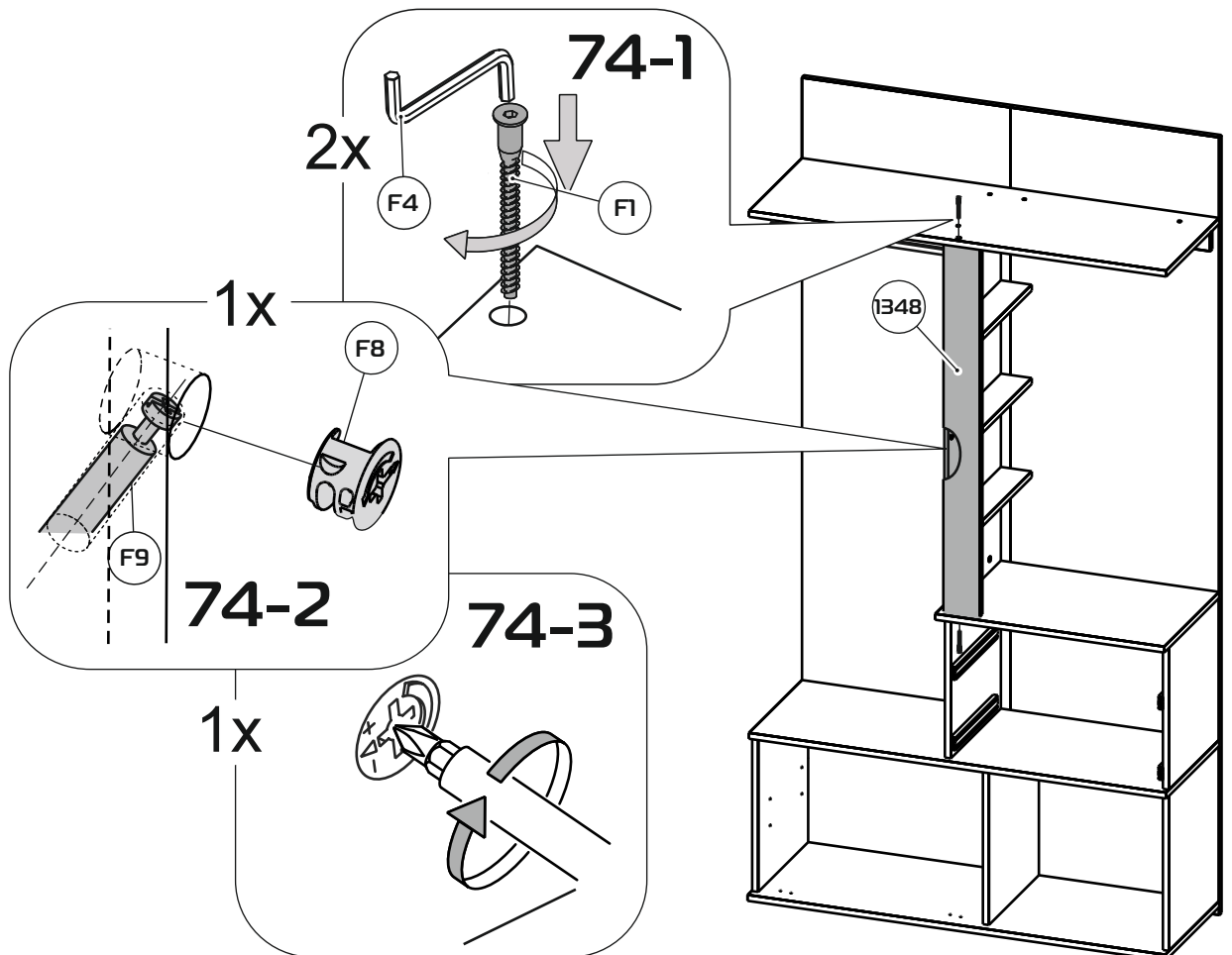

75

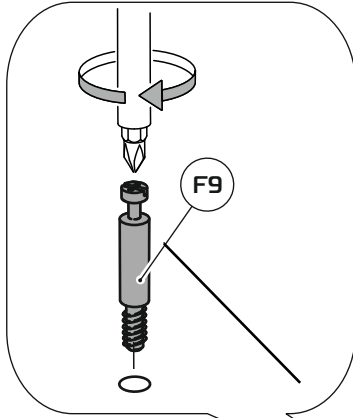

2x

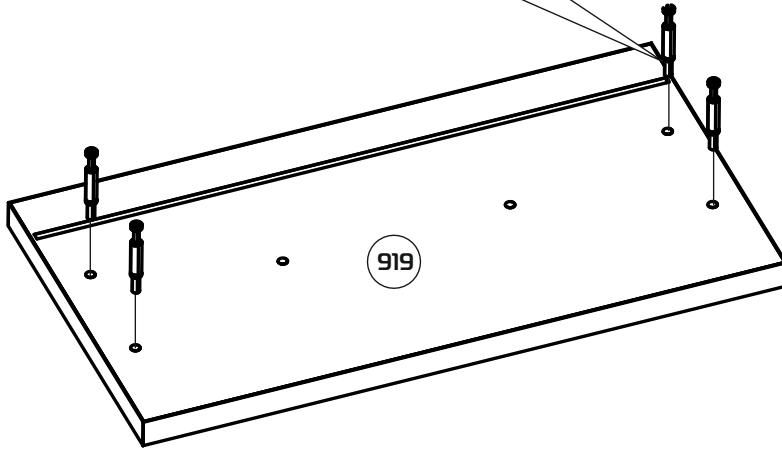
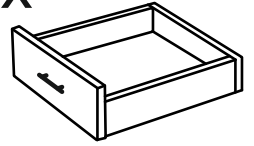

76

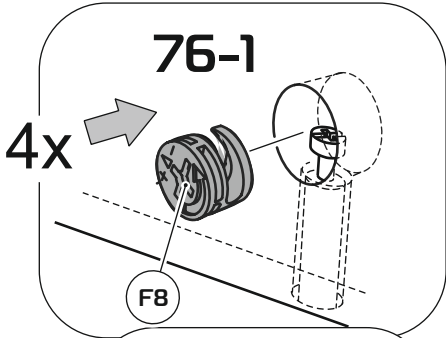

2x

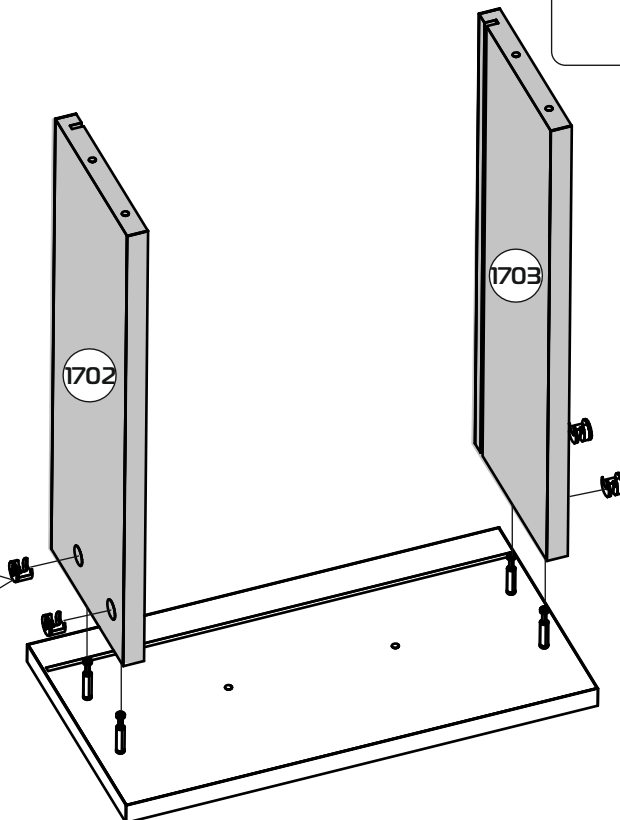
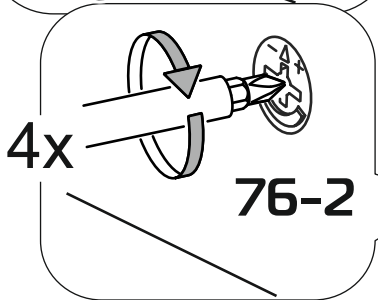
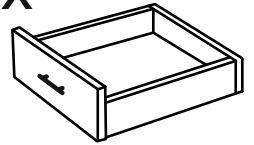

77

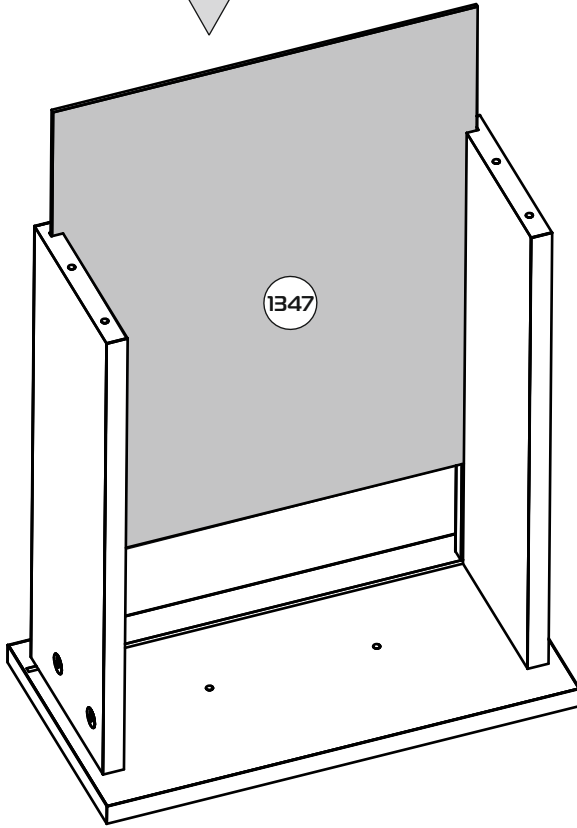
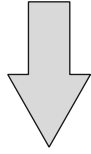

2x

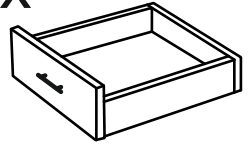

78

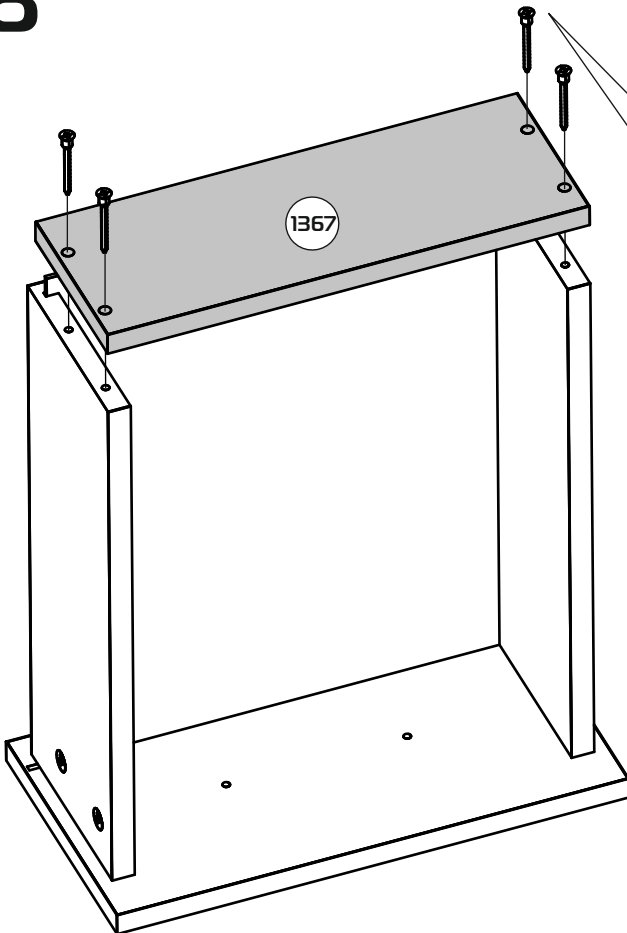

2x

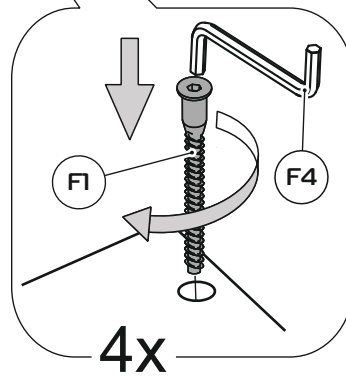
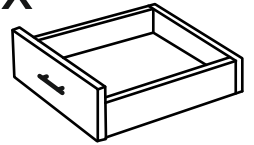

79

2x

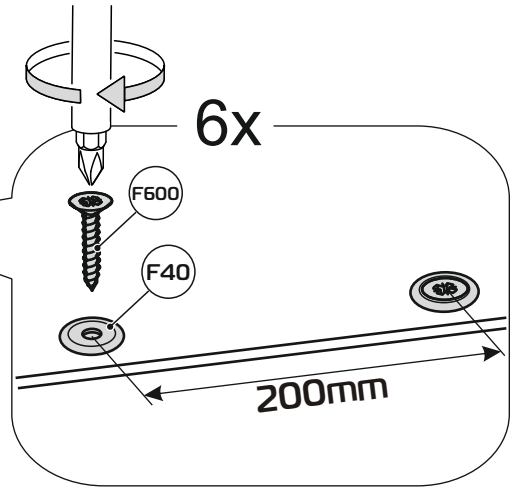
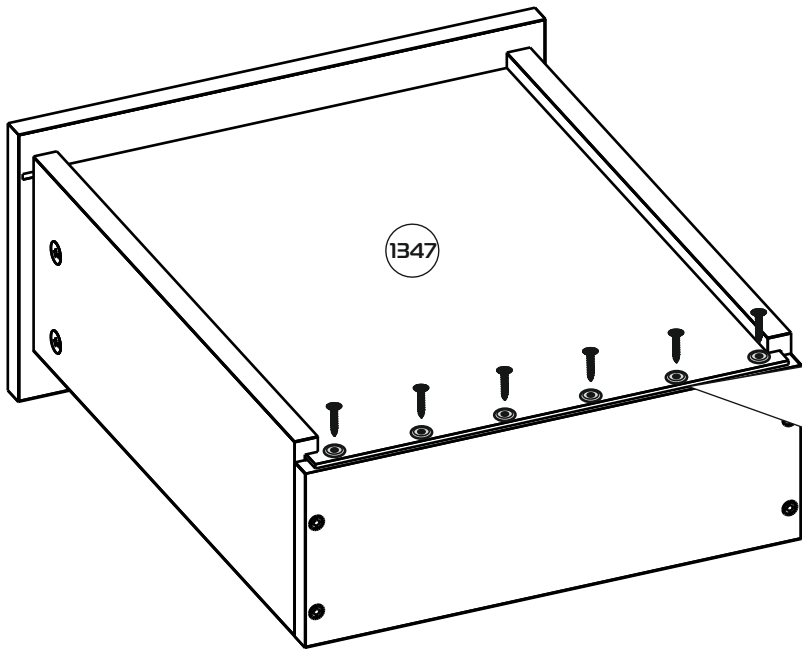
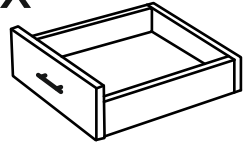

80

2x

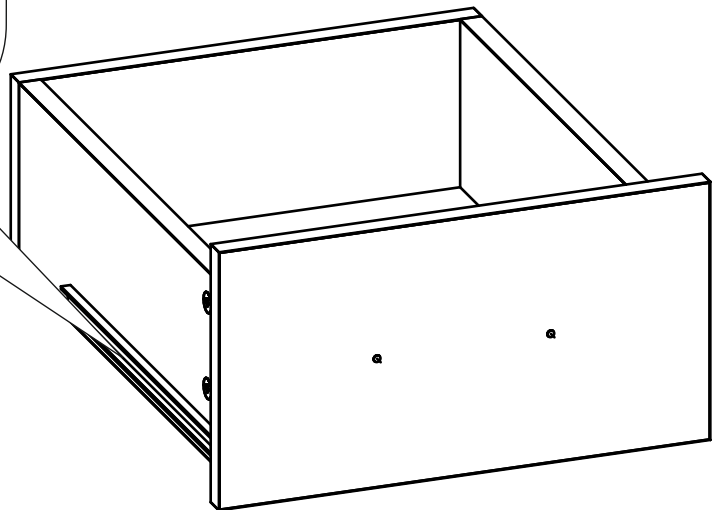
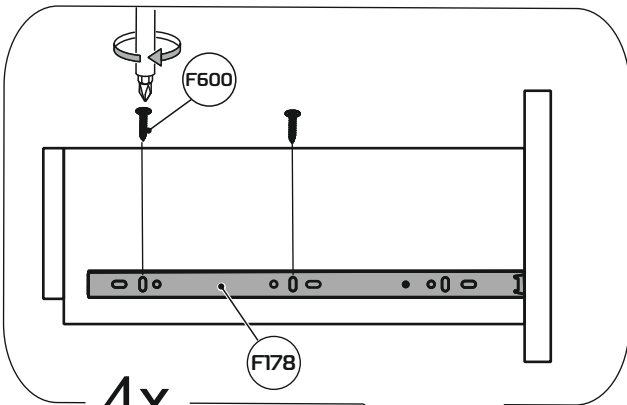
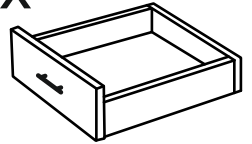

81

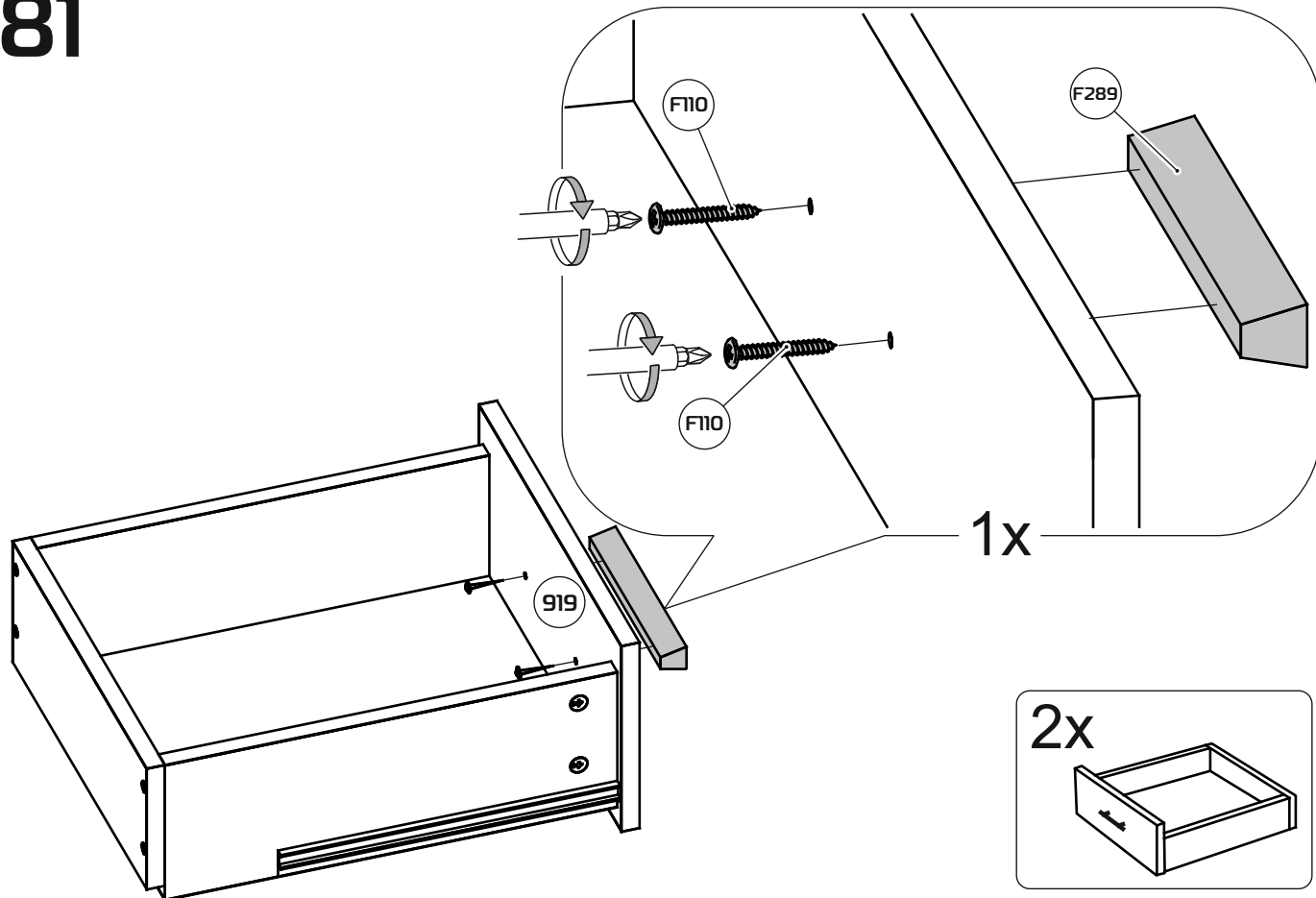

82

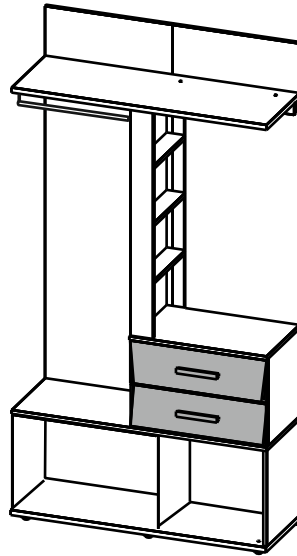
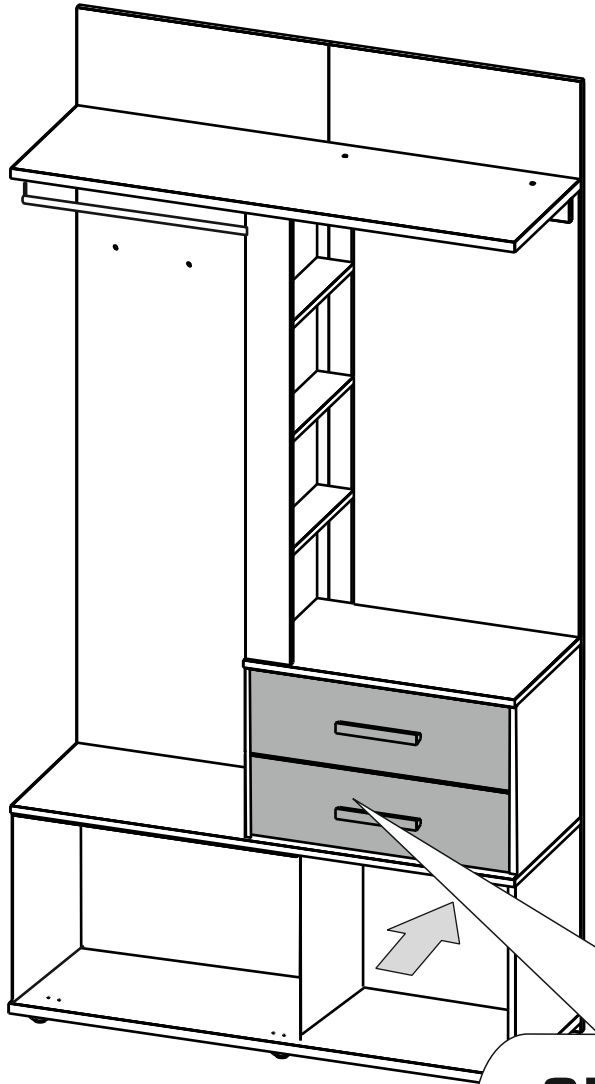

82-1

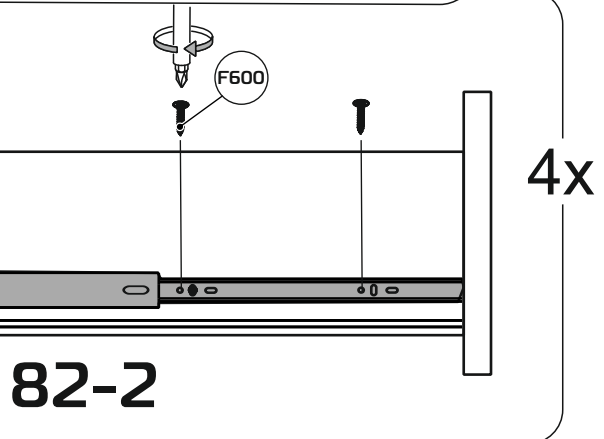
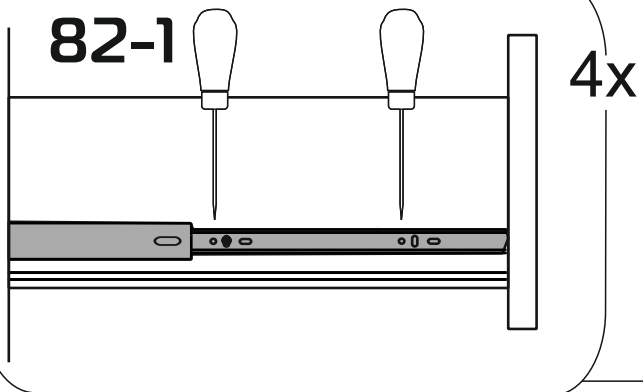

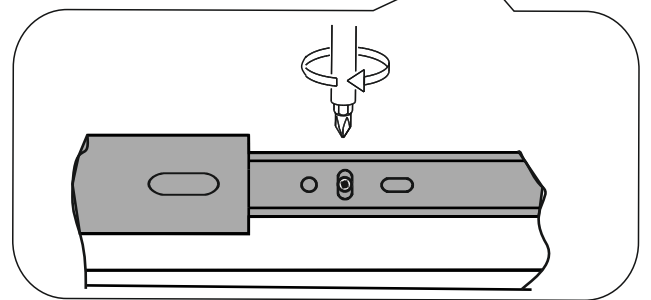
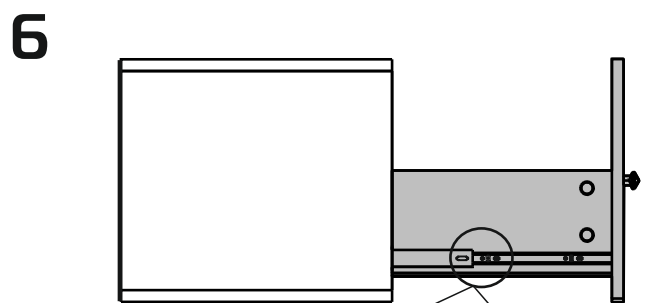
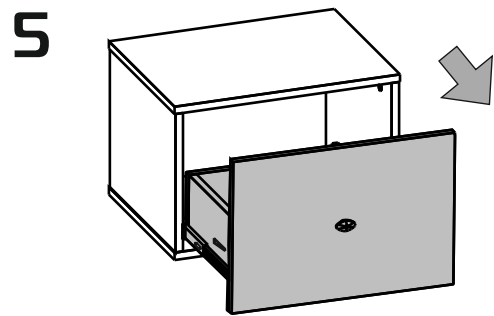
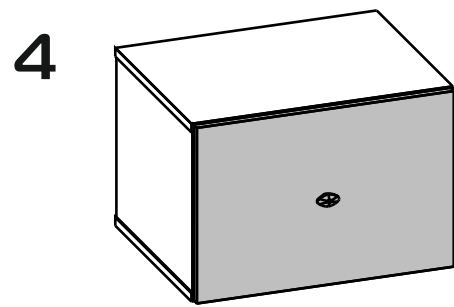
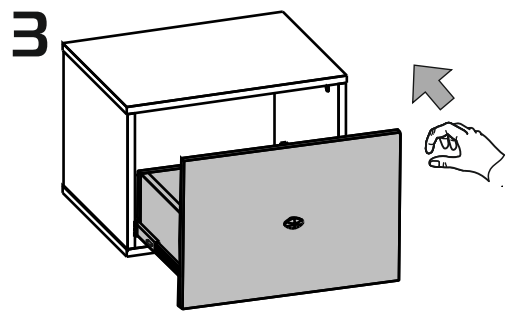
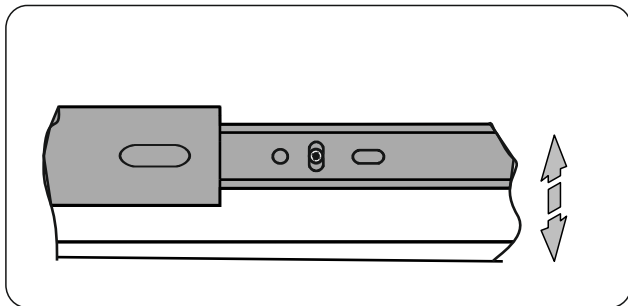
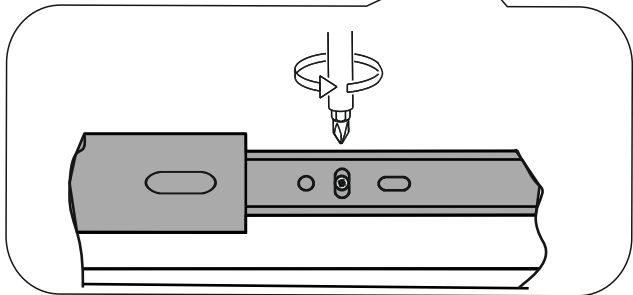
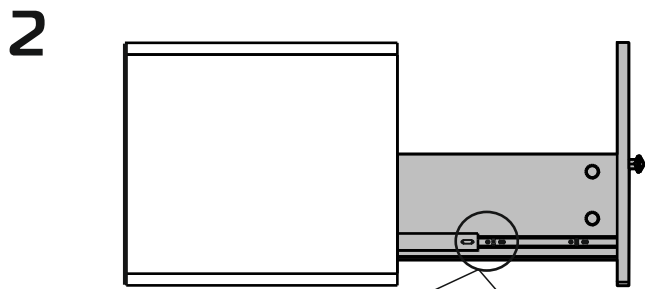
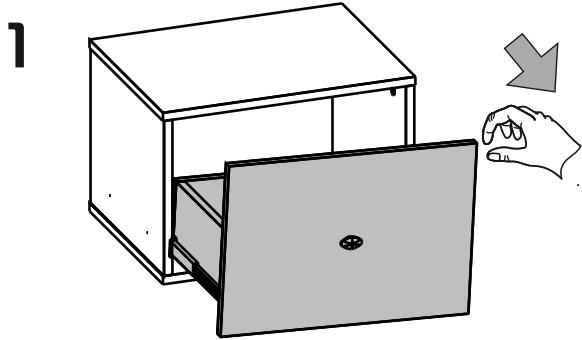
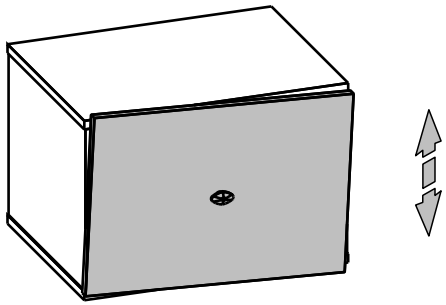

83

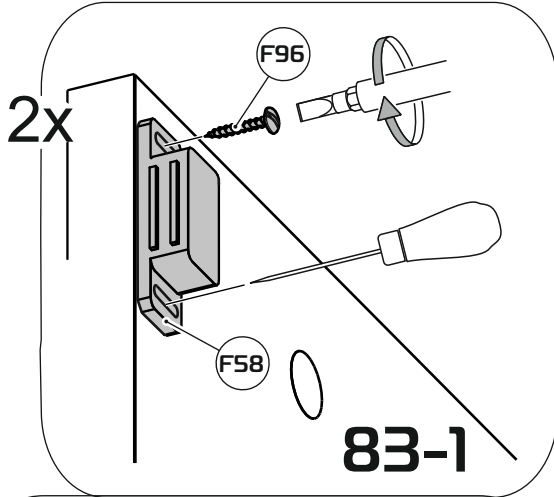

83-1

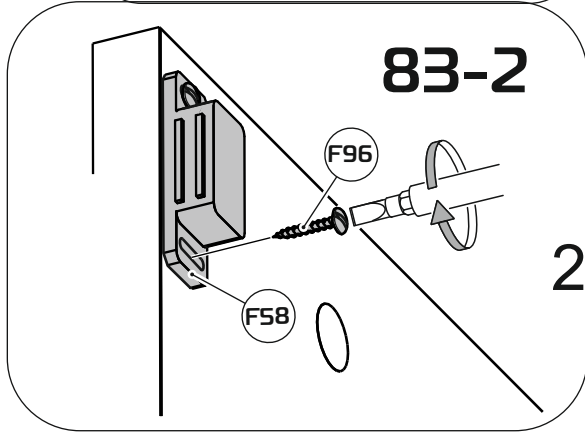
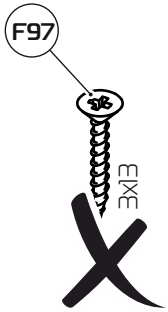

83-2

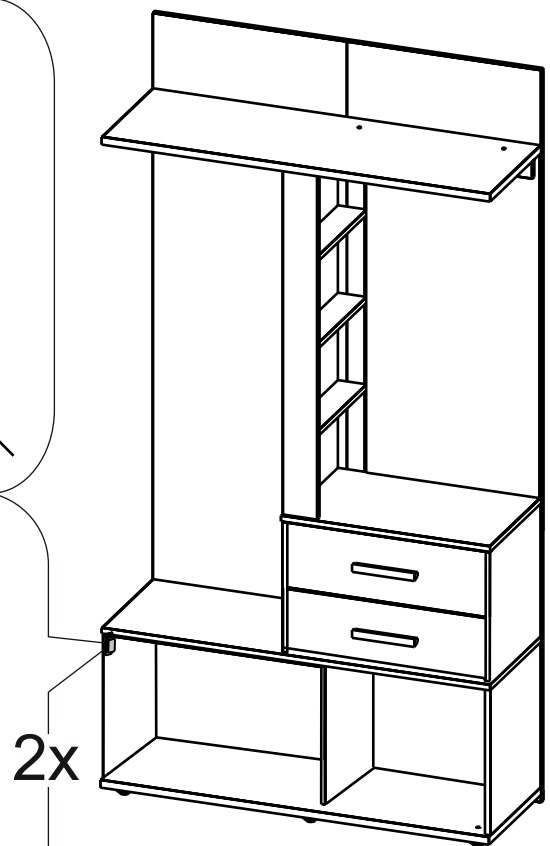

84



A

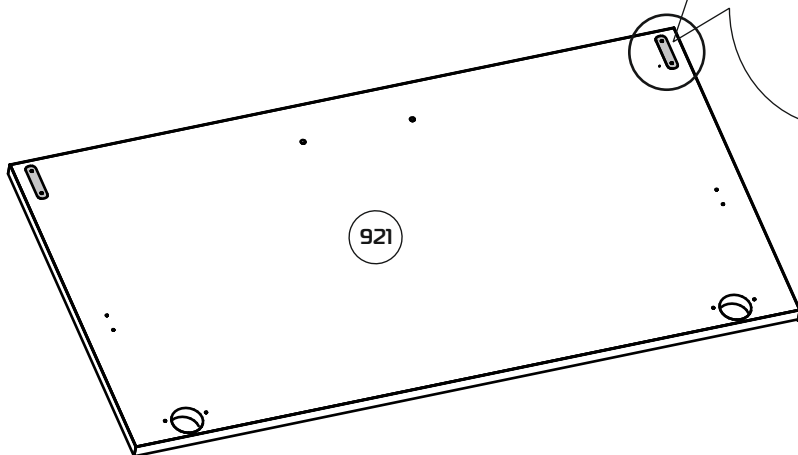
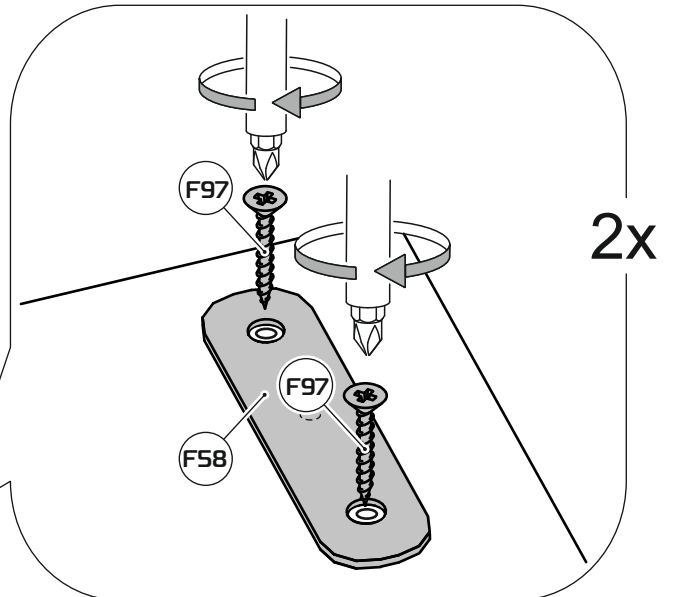
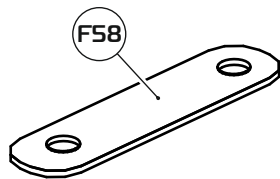

85



B

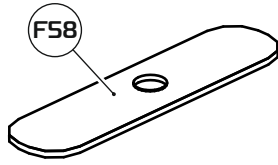

2x

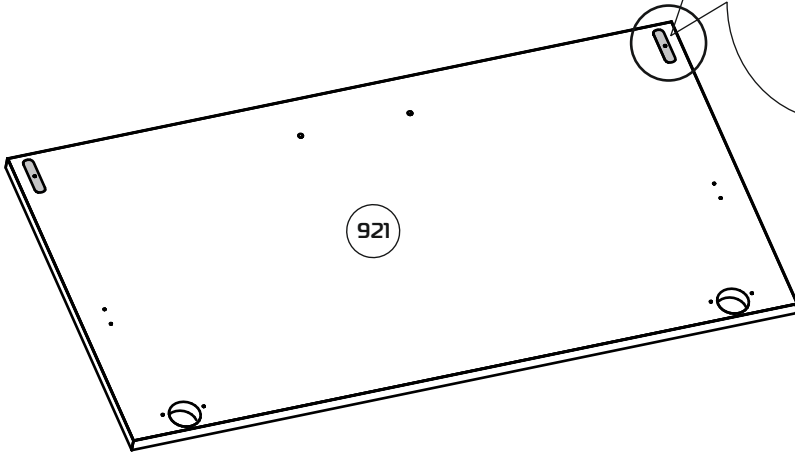
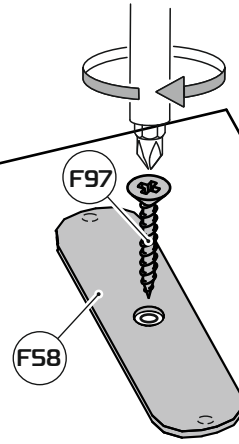

86

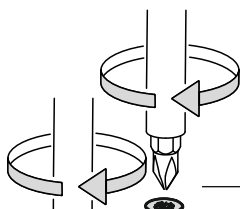

F600

F201

2x

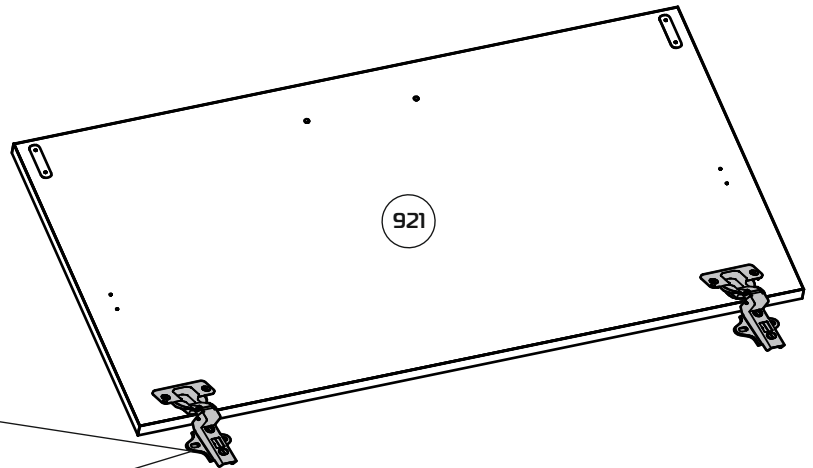

87

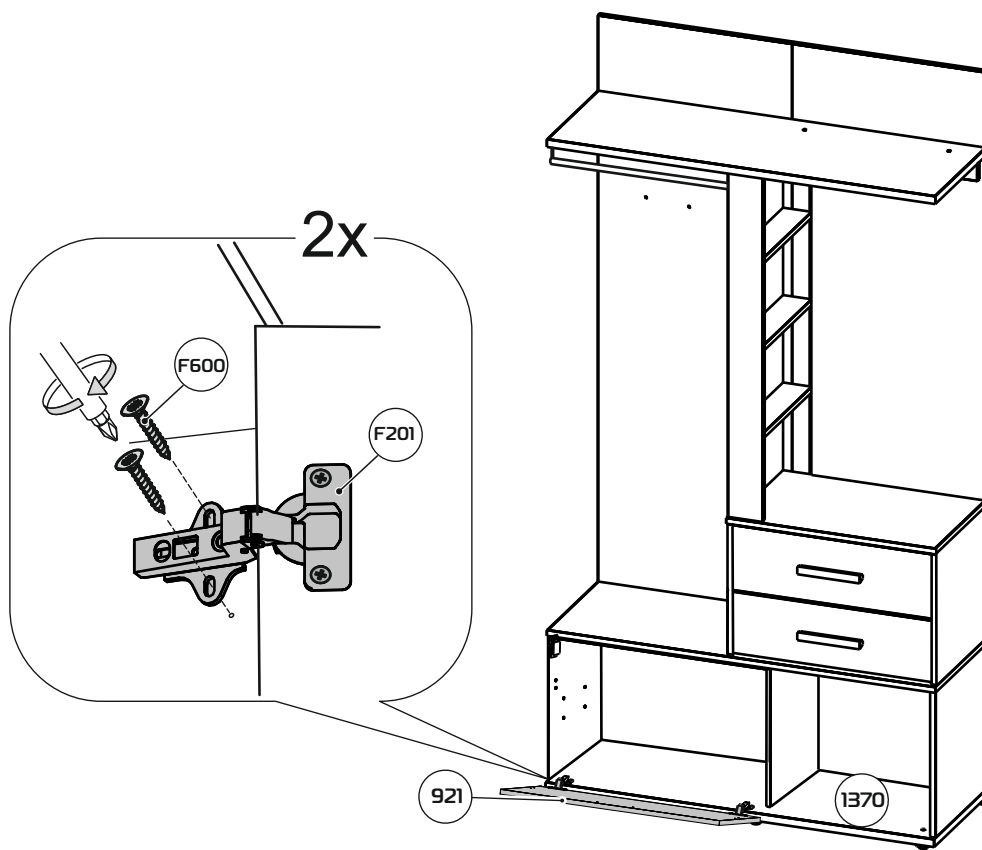

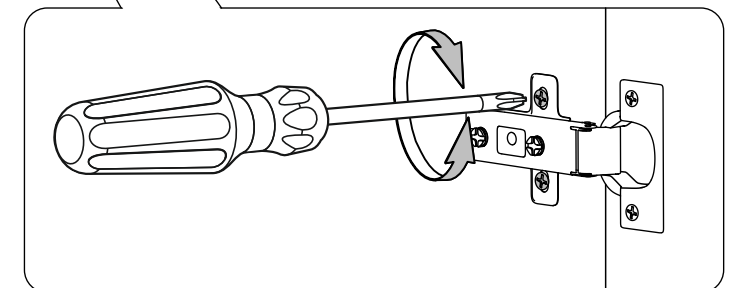
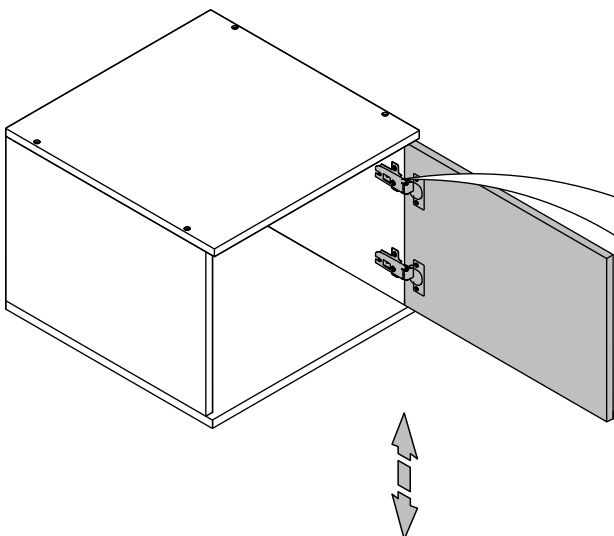
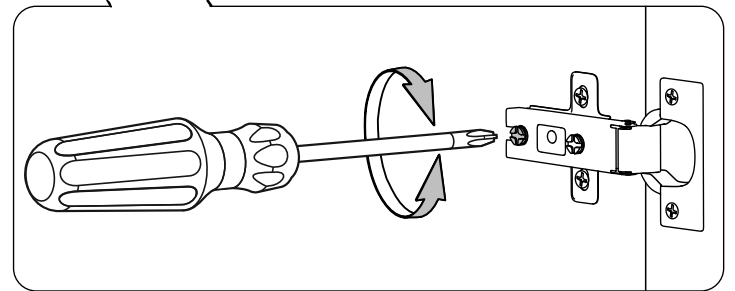
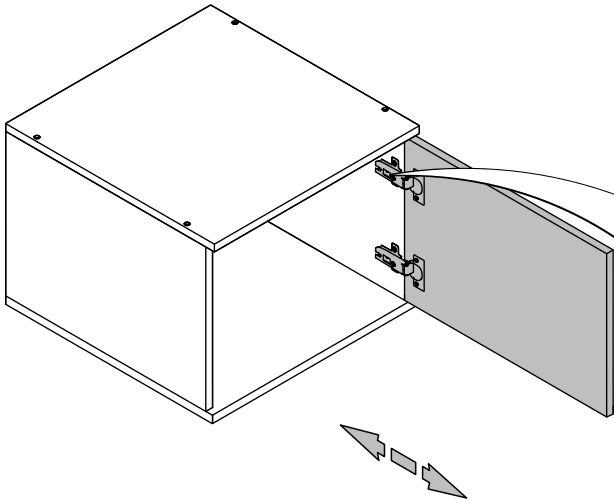
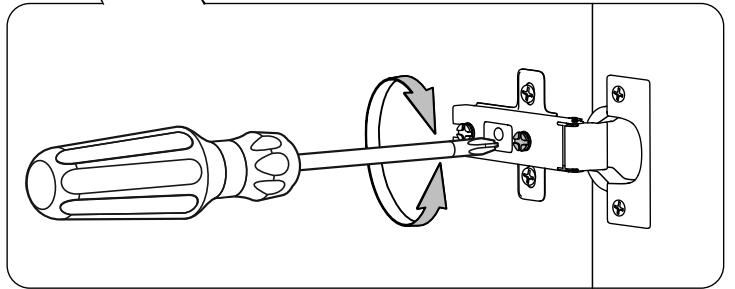
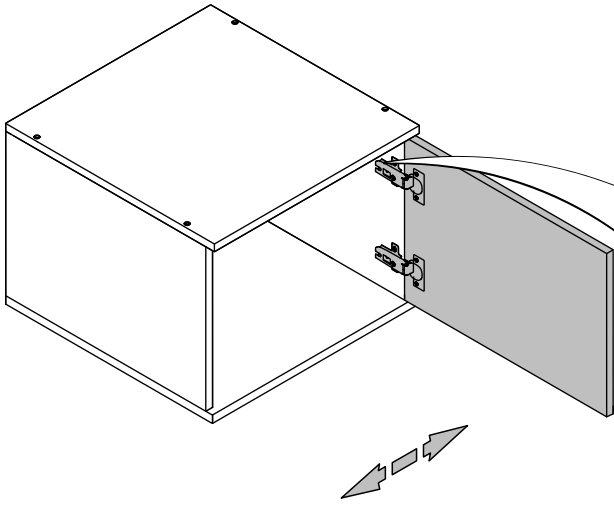

88

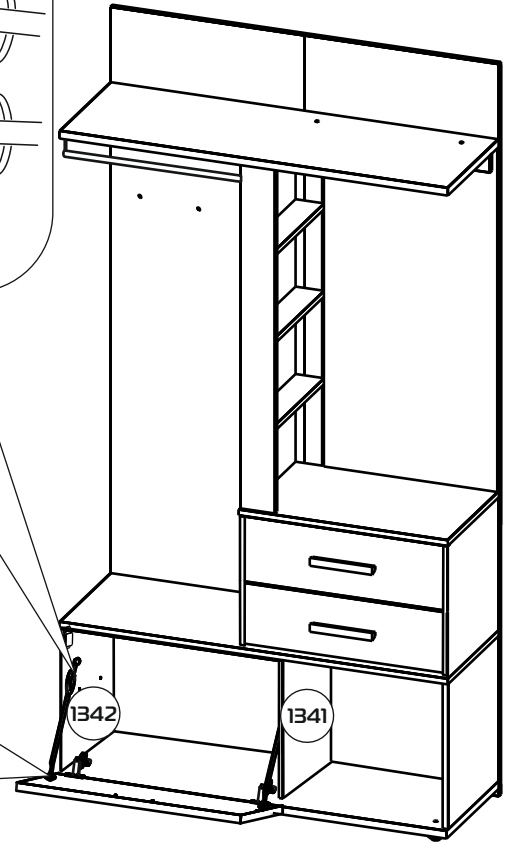
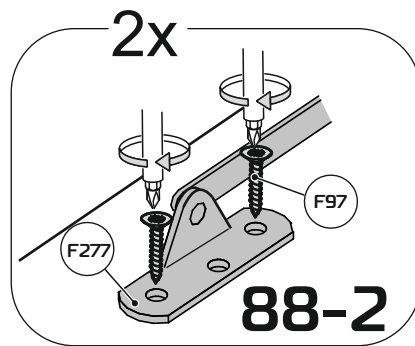
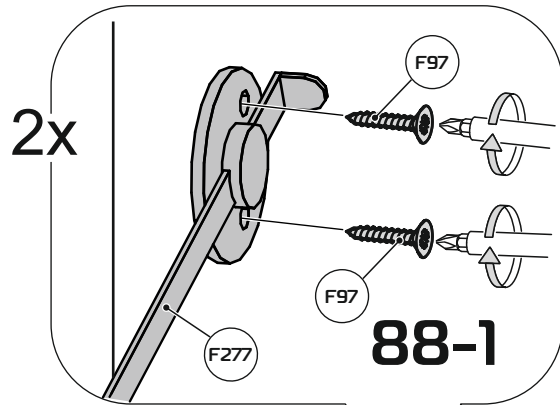

89

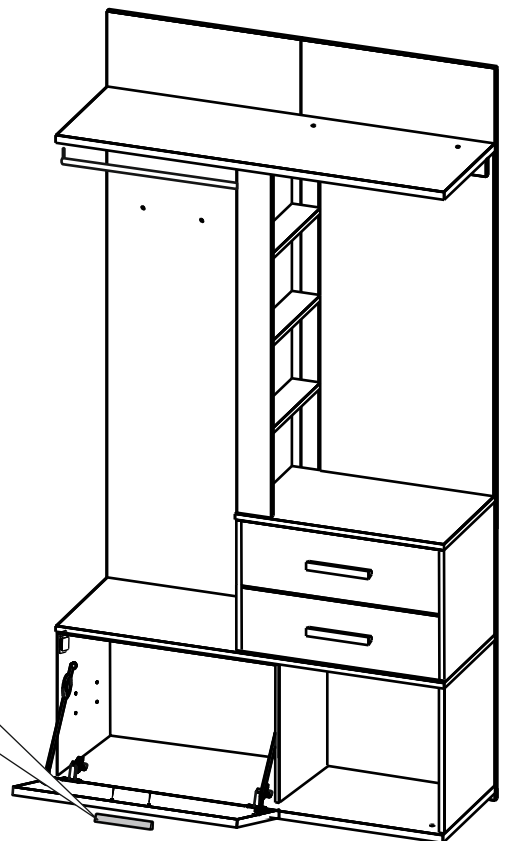
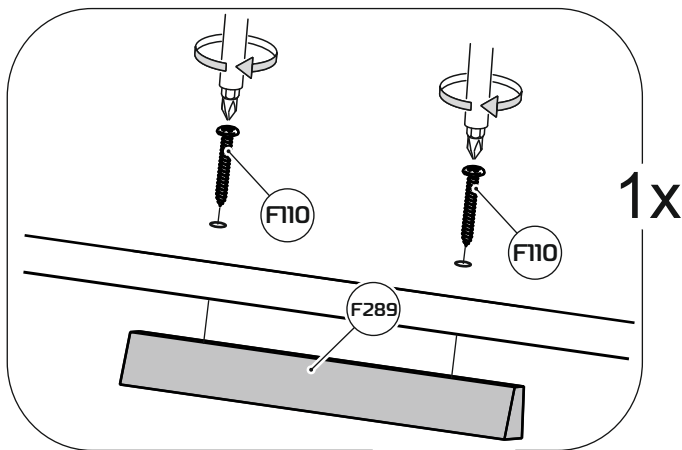

90

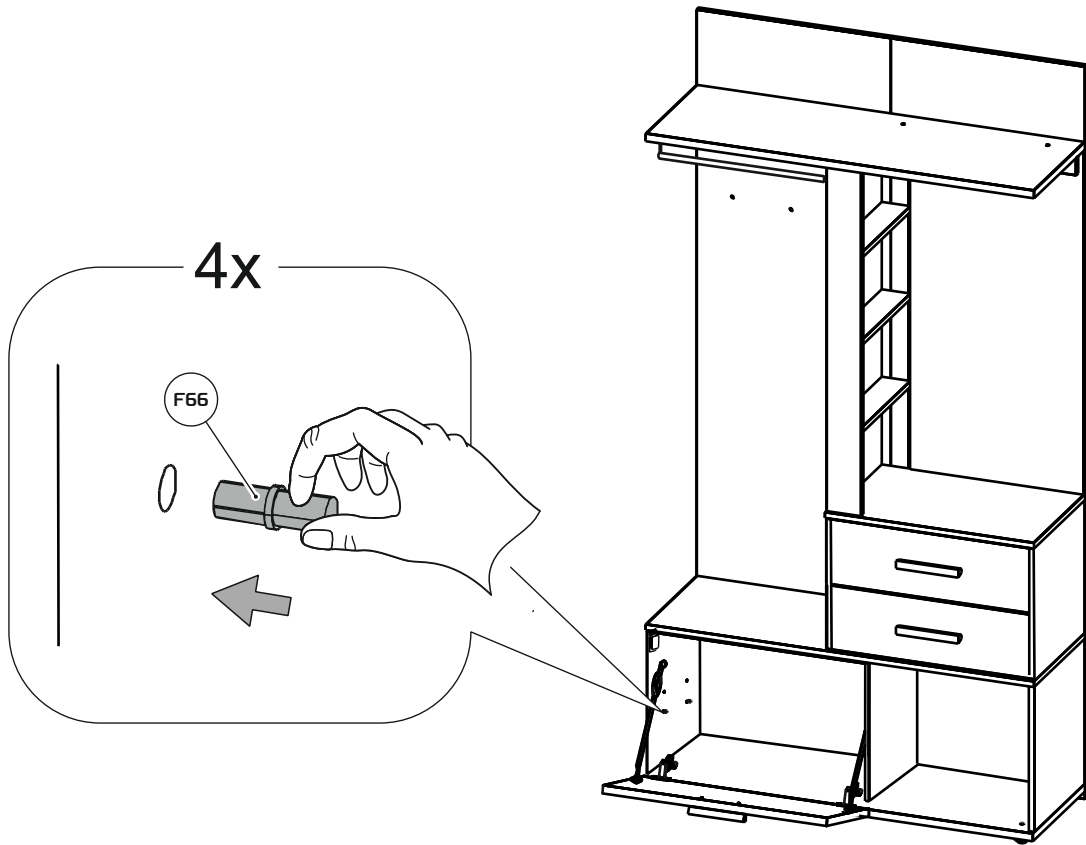

91

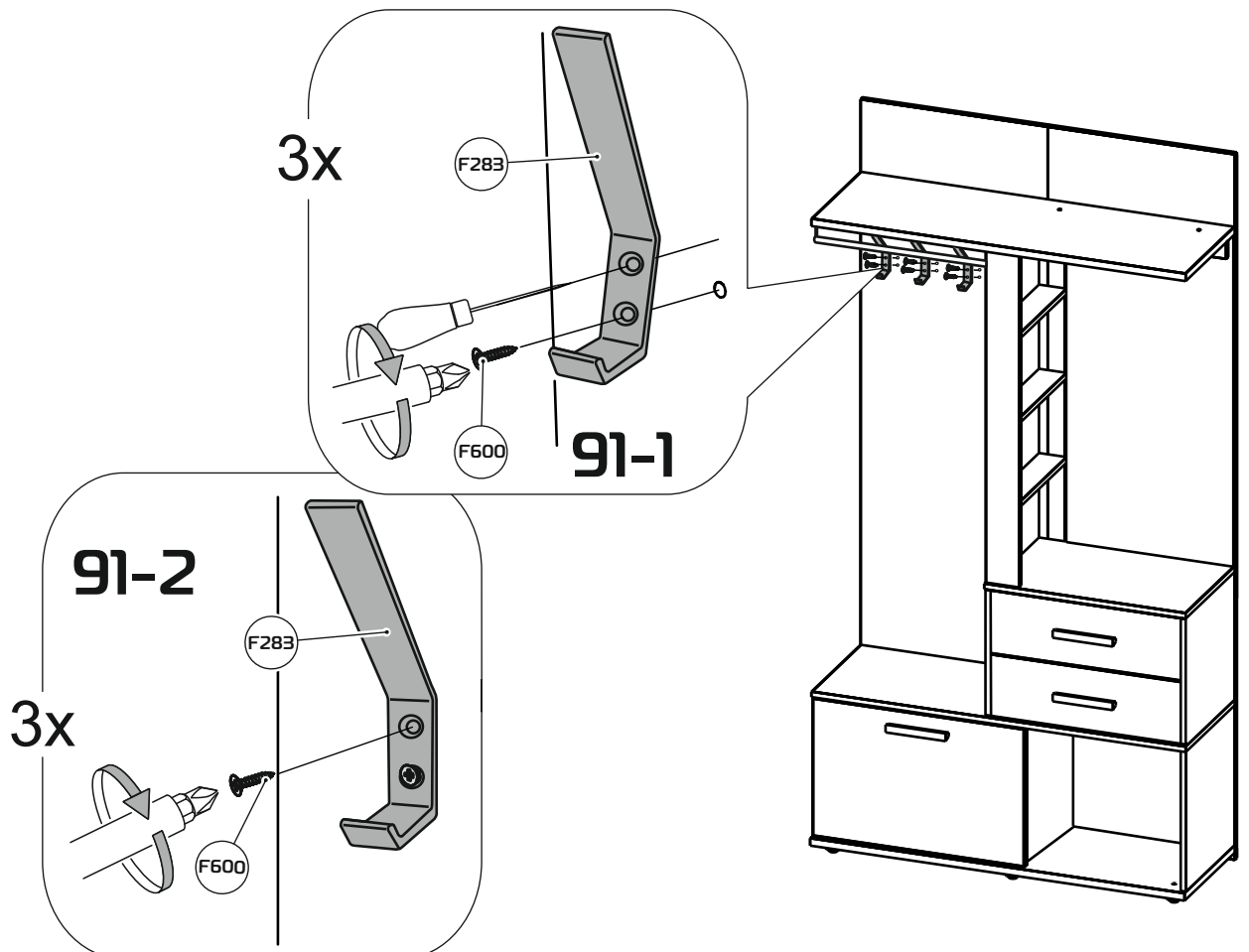

92

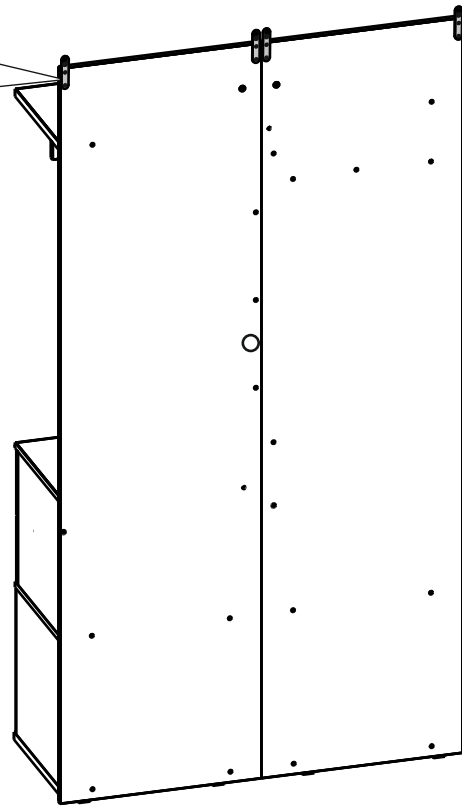
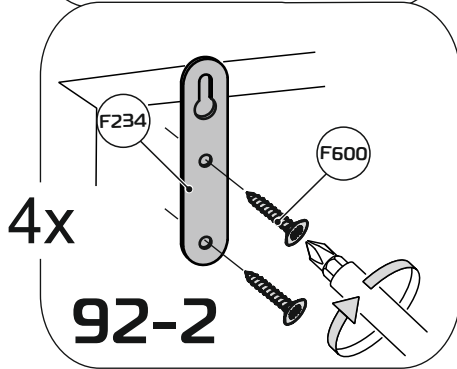
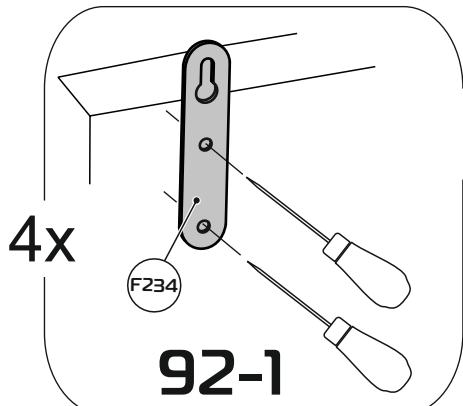

93

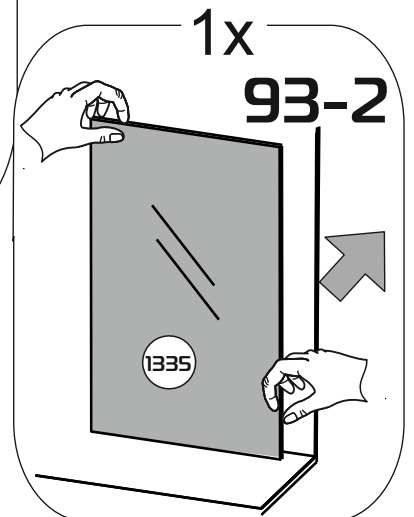
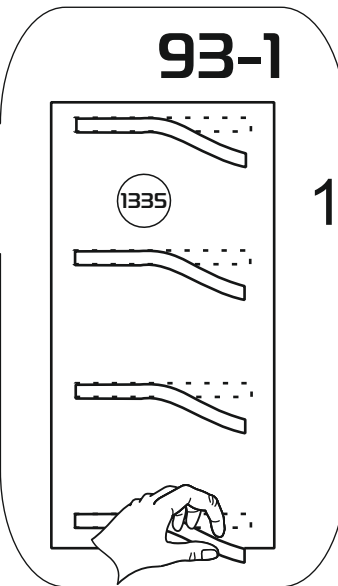
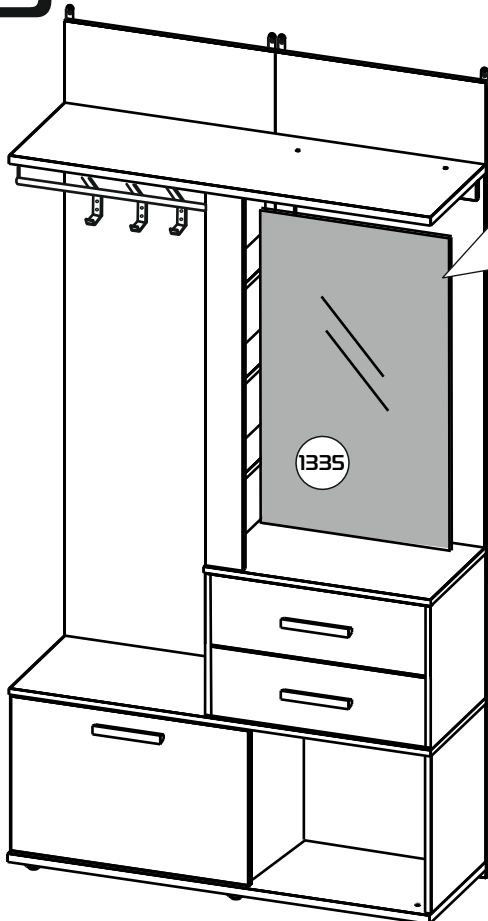

94

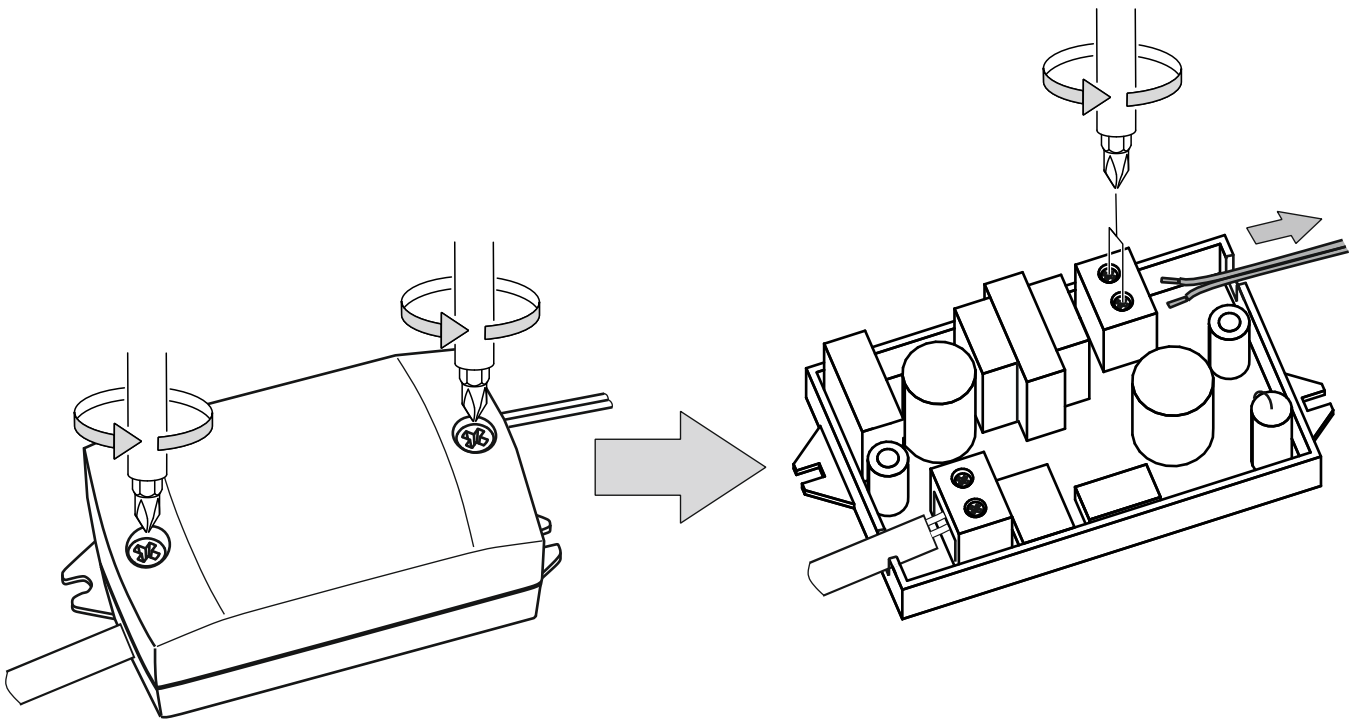

95

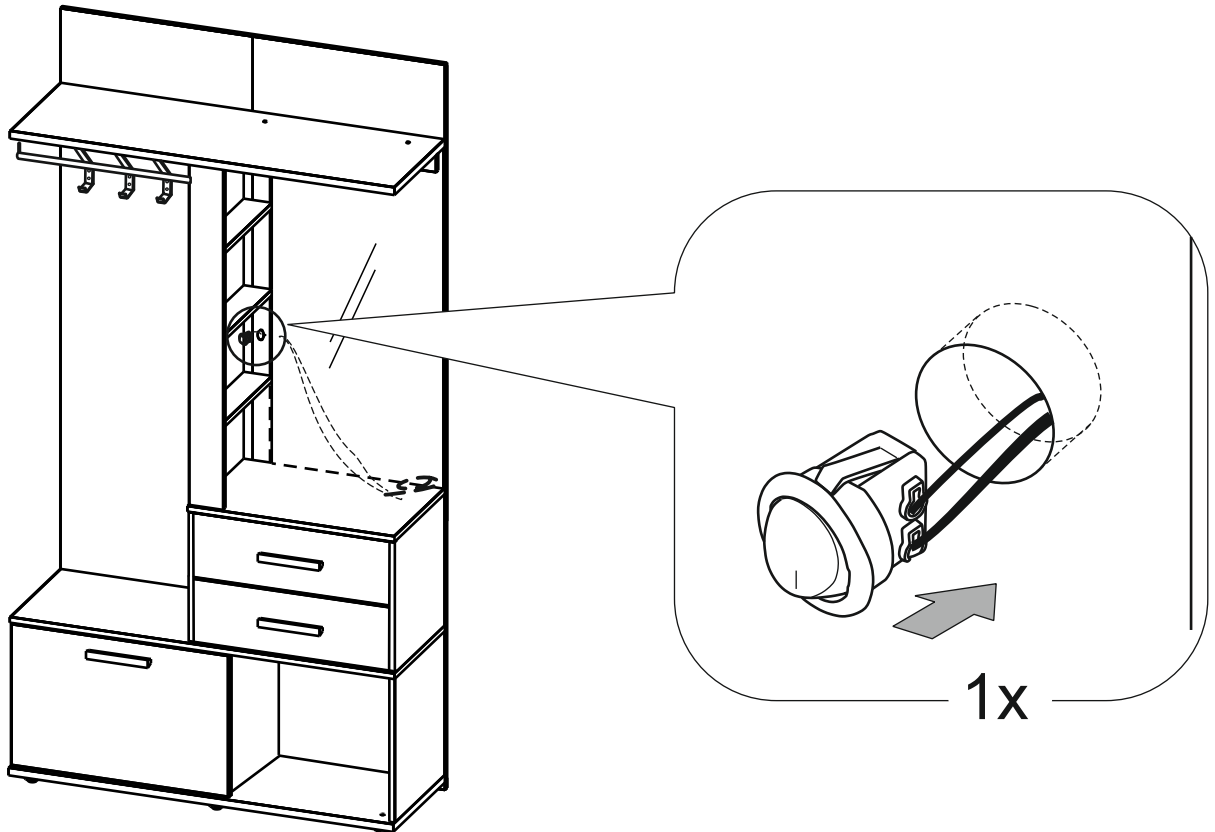

96

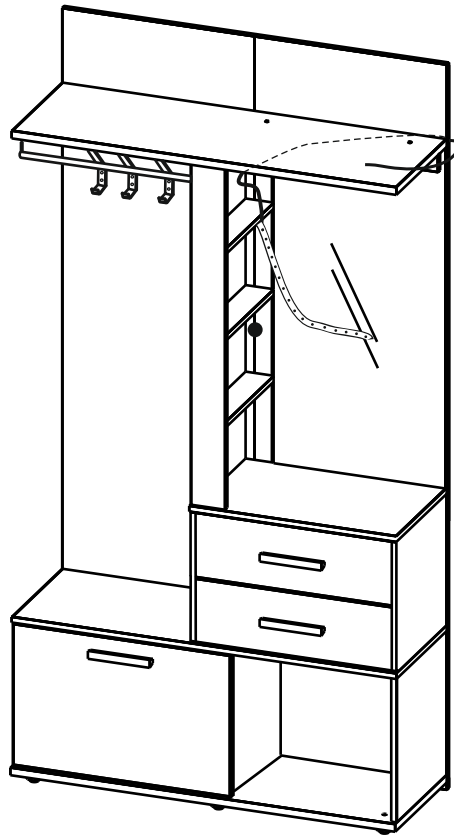

97

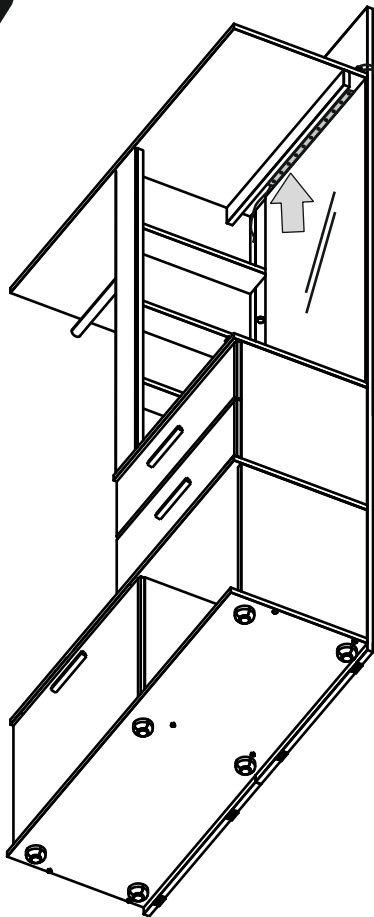

1x

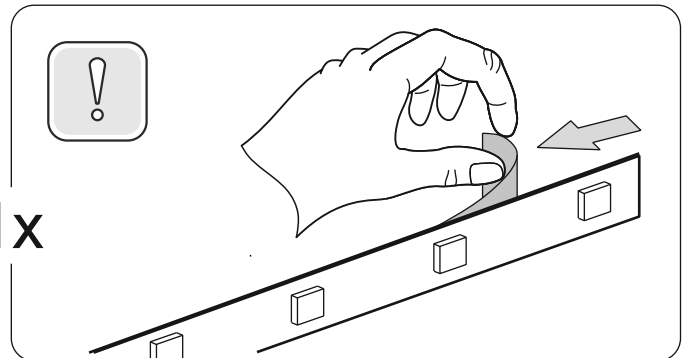

98

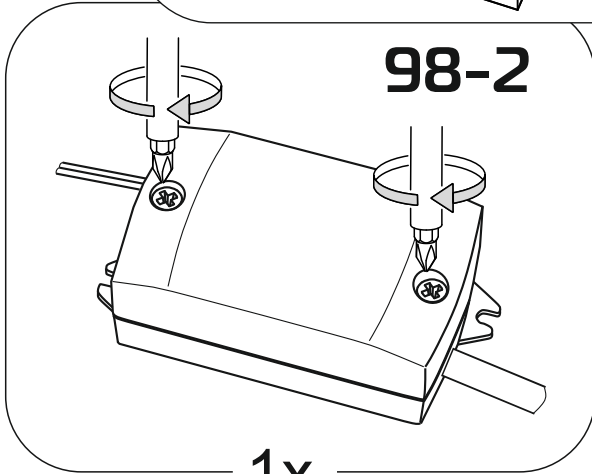
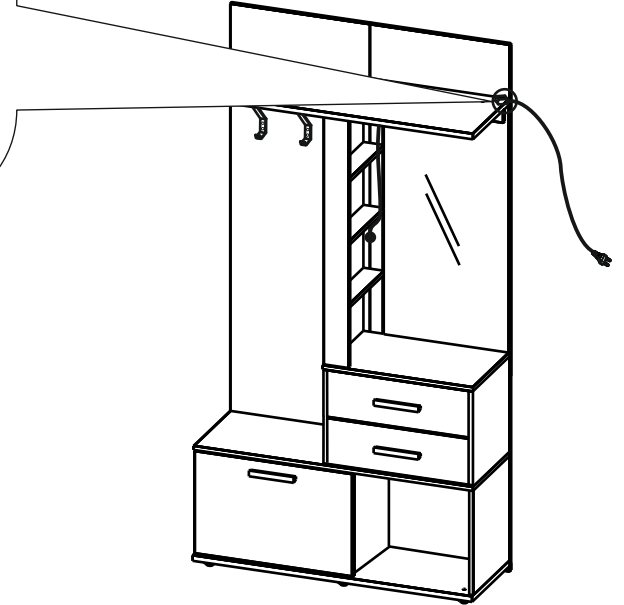
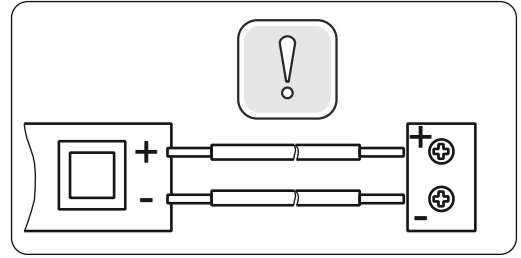
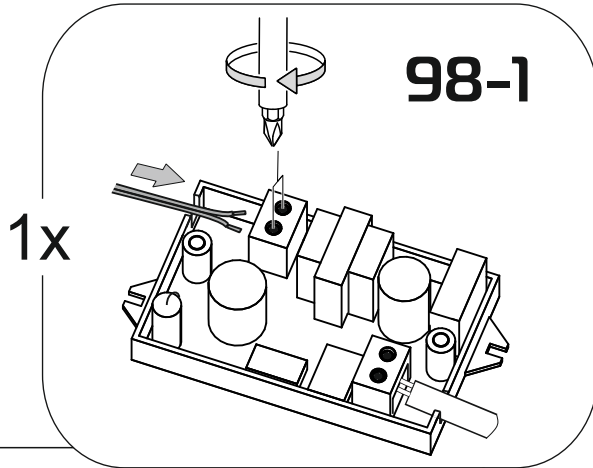

99

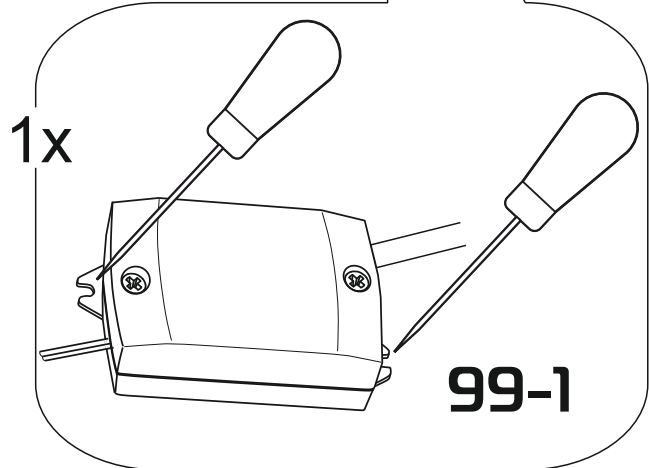
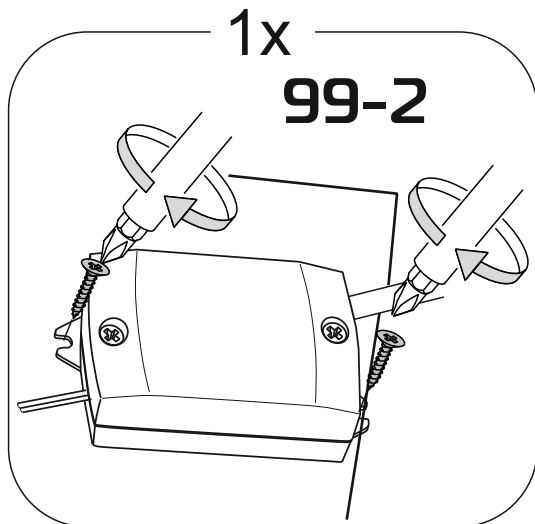
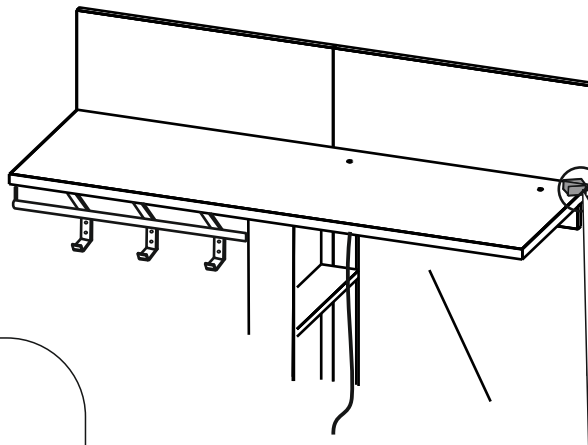

100

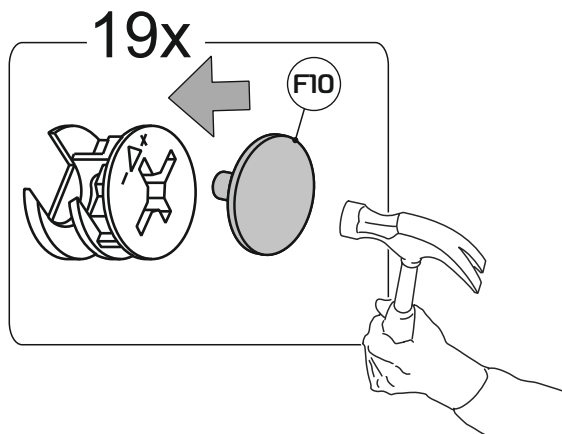
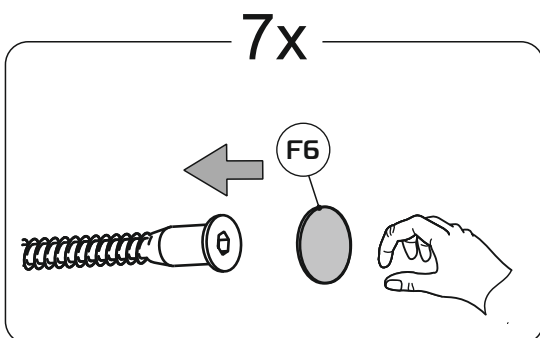
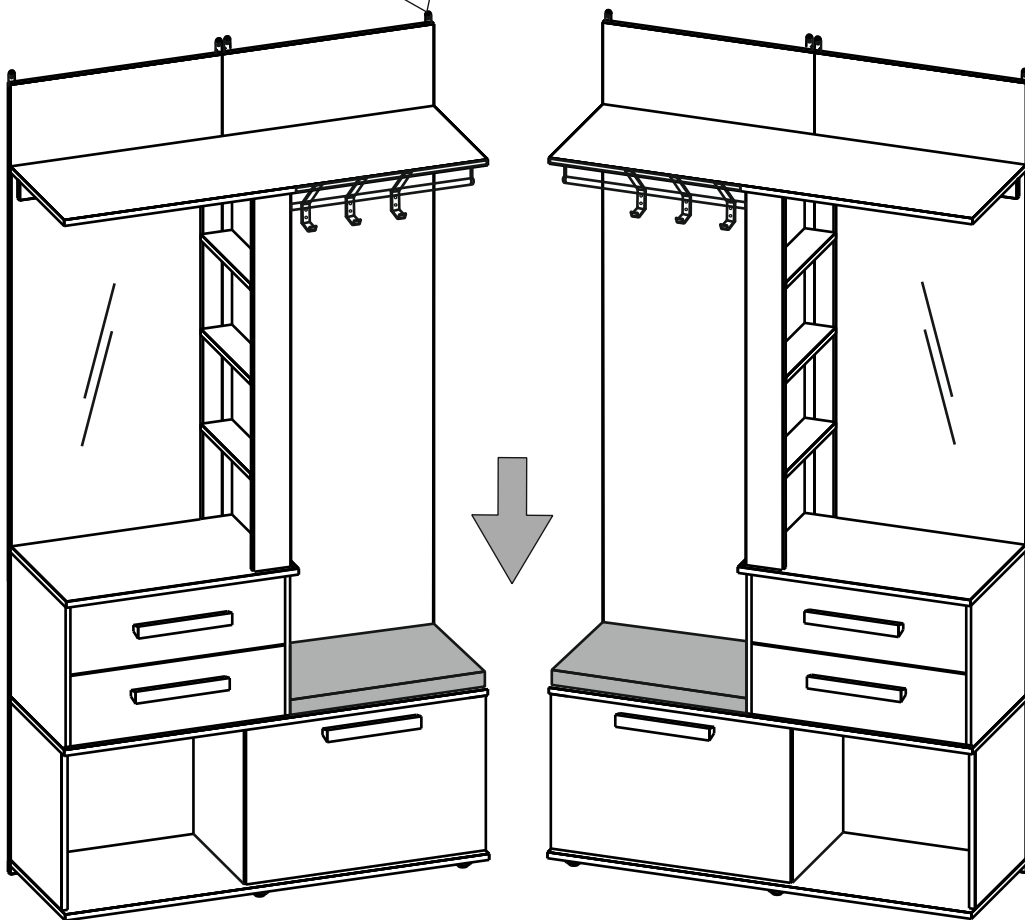
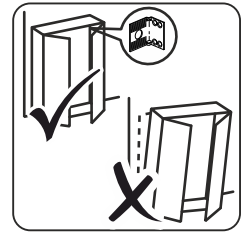
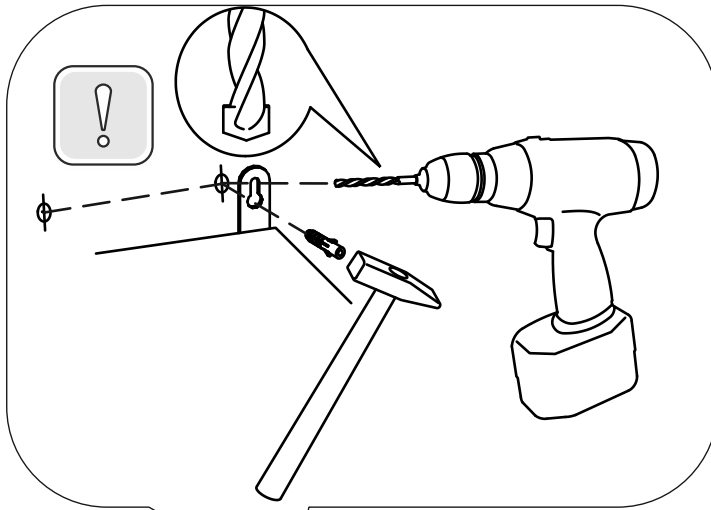

101

