



# НАБОР ВНЕДОРОЖНИКОВ «ДОРОГА ЯРОСТИ»

BUGGIES "FURY ROAD"



**ЗАВЕДИТЕ МОТОРЫ.**

**БУДЕТ ЖАРКО!**







**RU** Не поджигать!  
**ENG** Do not set fire to it!  
**DEU** Nicht anzunden!  
**FRA** Ne pas allumer!

**SPA** No prender fuego!  
**ITA** Non dare fuoco!  
**AR** يف رانلا عذرت ال

**RU** Рекомендации по сборке: извлекайте детали из деревянной карты, как показано в инструкции. Будьте осторожны, чтобы не сломать детали, если снимается с трудом, аккуратно вырежьте ее канцелярским ножом. Данная модель предназначена для сборки без использования клея. Все движущиеся части зачищайте наждачной бумагой и смазывайте воском во время сборки, чтобы уменьшить трение при эксплуатации модели. Все механизмы должны свободно вращаться.

**ENG** Assembly Instructions: Remove the parts from the wooden card as shown in the instructions. Be careful not to break the details, if it is difficult to remove, carefully cut it with a utility knife. This model is designed for assembly without the use of glue. All moving parts should be sanded and waxed during assembly to reduce friction during model operation. All mechanisms must rotate freely.

**DEU** Montageanleitung: Entfernen Sie die Teile wie in der Anleitung gezeigt von der Holzkarte. Achten Sie darauf, die Teile nicht zu zerbrechen. Wenn sie schwer zu entfernen sind, schneiden Sie sie vorsichtig mit einem Universalmesser ab. Dieses Modell ist für die Montage ohne Verwendung von Klebstoff konzipiert. Alle beweglichen Teile sollten beim Zusammenbau geschliffen und gewachst werden, um die Reibung während des Modellbetriebs zu verringern. Alle Mechanismen müssen sich frei drehen können.

**FRA** Instructions d'assemblage : retirez les pièces de la carte en bois comme indiqué dans les instructions. Faites attention à ne pas casser les détails, s'il est difficile à retirer, coupez-le soigneusement avec un couteau tout usage. Ce modèle est conçu pour un assemblage sans utilisation de colle. Toutes les pièces mobiles doivent être ponçées et cirées lors de l'assemblage pour réduire la friction pendant le fonctionnement du modèle. Tous les mécanismes doivent tourner librement.

**SPA** Instrucciones de montaje: Retire las piezas de la tarjeta de madera como se muestra en las instrucciones. Tenga cuidado de no romper los detalles, si es difícil de quitar, córtelo con cuidado con un cuchillo. Este modelo está diseñado para ensamblarse sin el uso de pegamento. Todas las piezas móviles deben lijarse y encerarse durante el montaje para reducir la fricción durante el funcionamiento del modelo. Todos los mecanismos deben girar libremente.

**DEU** Istruzioni di montaggio: rimuovere le parti dalla scheda di legno come mostrato nelle istruzioni. Fare attenzione a non rompere i dettagli, se risulta difficile rimuoverlo, tagliarlo con cura con un taglierino. Questo modello è predisposto per il montaggio senza l'utilizzo di colla. Tutte le parti mobili devono essere levigate e cerate durante l'assemblaggio per ridurre l'attrito durante il funzionamento del modello. Tutti i meccanismi devono ruotare liberamente.

**AR** ناك اذ، لي صرافت ال رسك مدع يل ع صرحا • تامي ل عت ال يف حضوم وه امك ذبي شخ ال ق اطبال نم • ازج ال ة ل ازب مق • عي مجت ال تامي ل عت بجي • ارغ ال مادخت سا نود عي مجت لل ج ذوم نل اذه ميم صت مت • تام ادخت سالا ددعتم ني كسب ذيانعب اهرقب مق، اهت لازا بعصر ال نم تاي ل ال عي مج رودت نا بجي • ج ذوم نل لي غشت • انثا كاك تح ال ل ل لقت ل عي مجت ال • انثا اهرقم شت و ة كرحتم ال • ازج ال عي مج ة رفرنص ذيرحب



Есть вопросы по качеству и сборке?  
Не хватило деталей или сломались.  
Сканируй QR-код и напиши нам в чат.  
Или на почту [drovo@drovo.ru](mailto:drovo@drovo.ru)



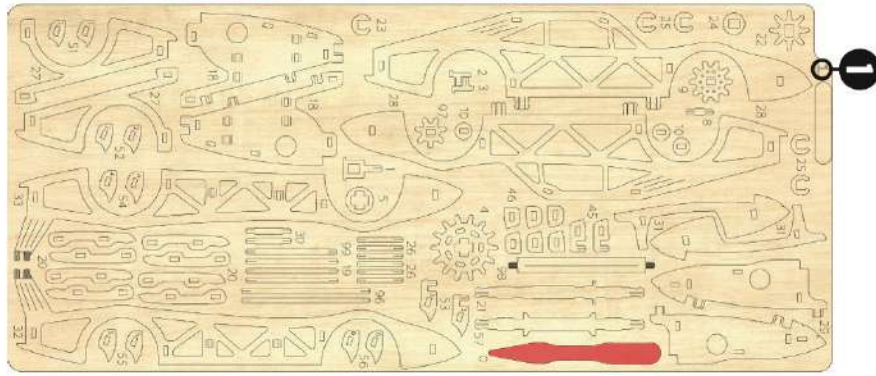

**RU** Запасные части  
**ENG** Spare parts  
**DEU** Ersatzteilen  
**FRA** Pièces de rechange  
**SPA** Piezas de repuesto  
**ITA** Ricambio  
**AR** رايغ لاء عطق

**RU** Вспомогательный инструмент для выдавливания деталей / **ENG** A tool for measurement and assembly / **DEU** Ein Werkzeug zum Messen und Montieren / **FRA** Un outil de mesure et d'assemblage / **SPA** Una herramienta de medición y montaje / **ITA** Uno strumento per la misurazione e l'assemblaggio / **AR** عي مچت لاو سايق ل ل ادا

**RU** Символы / **ENG** Symbols / **DEU** Symbole / **FRA** Symboles / **SPA** Símbolos / **ITA** Simboli / **AR** زمر وا فرح



**RU** Смажьте деталь воском при помощи свечи.  
**ENG** Wax the part with a candle.  
**FRA** Lubrifier la pièce avec de la cire.  
**SPA** Lubricar la pieza con cera.  
**ITA** Lubrificare la parte con cera.  
**AR** ع م ش ل ا ب ء ز ج ل ا ن ه د



**RU** Средняя резинка.  
**ENG** Medium rubber band.  
**DEU** Mittleres Gummiband.  
**FRA** Élastique moyen.  
**SPA** Banda de goma mediana.  
**ITA** Elastico medio.  
**AR** ط س و ت م ي ط ا ط م ط ي ر ش ط ي ر ش



**RU** Зашлифуйте для удаления заусенцев.  
**ENG** Sand to remove burrs.  
**DEU** Schleifen, um Grate zu entfernen.  
**FRA** Poncer pour enlever les bavures.  
**SPA** Lijar para eliminar rebabas.  
**ITA** Sabbiare per rimuovere le sbavature.  
**AR** ت ا ء و ت ن ل ا ء ل ا ز ا ل ل م ر ل ا



**RU** Широкая резинка.  
**ENG** Wide rubber band.  
**DEU** Breites Gummiband.  
**FRA** Large élastique.  
**SPA** Banda de goma ancha.  
**ITA** Elastico largo.  
**AR** ض ي ر ع ي ط ا ط م ط ي ر ش



**RU** Смажьте деталь воском и зашлифуйте для удаления заусенцев.  
**ENG** Sand to remove burrs and wax the part with a candle.  
**DEU** Wachsen Sie das Teil und schleifen Sie es, um Grate zu entfernen.  
**FRA** Cirer la pièce et poncer pour éliminer les bavures.  
**SPA** Encere la pieza y lije para eliminar las rebabas.  
**ITA** Incerare la parte e carteggiare per rimuovere le sbavature.  
**AR** ت ا ء و ت ن ل ا ء ل ا ز ا ل ل م ر ل ا و ء ز ج ل ا ع م ش



**RU** Большая резинка  
**ENG** Large rubber band  
**DEU** großes Gummiband  
**FRA** gros élastique  
**SPA** banda de goma grande  
**ITA** grande elastico  
**AR** ر ي ب ك ي ط ا ط م ط ي ر ش



**RU** Держите пружину крепко при ее распаковке и установке для избежания травмирования. Требуется помощь взрослых.  
**ENG** Hold the spring firmly when unpacking and installing it to avoid injury. Adult assistance is required.



**RU** Обратит внимание. Проверьте правильность ориентации и позиционирования детали.  
**ENG** Pay attention. Check for correct orientation and positioning.  
**DEU** Achten. Auf korrekte Ausrichtung und Positionierung prüfen.  
**FRA** Fais attention. Vérifiez l'orientation et le positionnement corrects.  
**SPA** Presta atención. Verifique la orientación y el posicionamiento correctos.  
**ITA** Fai attenzione. Verificare il corretto orientamento e posizionamento.  
**AR** ع ق ا و م ل ا د ي د ج ت و ع ي ح ص ل ا د ا ج ت ا ل ا ن م ق ق ح ت . ء ب ت ن ا

**DEU** Halten Sie die Feder beim Auspacken und Installieren fest, um Verletzungen zu vermeiden. Die Hilfe eines Erwachsenen ist erforderlich.

**FRA** Tenez fermement le ressort lors du déballage et de l'installation afin d'éviter toute blessure. L'aide d'un adulte est nécessaire.

**SPA** Sujete firmemente el muelle al desembalarlo e instalarlo para evitar lesiones. Se requiere la ayuda de un adulto.

**ITA** Tenere saldamente la molla durante il disimballaggio e l'installazione per evitare lesioni. È necessaria l'assistenza di un adulto.

**AR** ب ن ج ت ل ء ب ي ك ر ت و ء غ ي ر ف ت د ن ع م ا ك ا ج ا ب ض ب ا ن ل ا ك س م ا  
 ن ي غ ل ا ب ل ا ء ء ع ا س م ب و ل ط م . ء ب ا ص ل ا



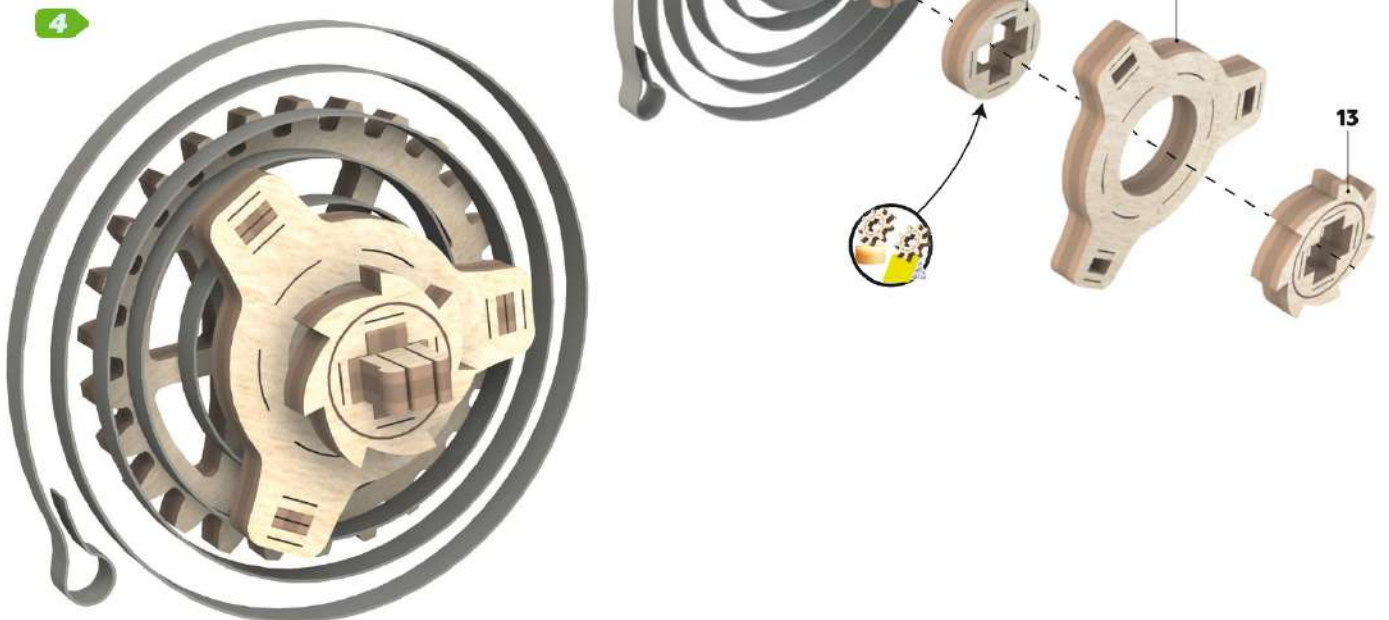
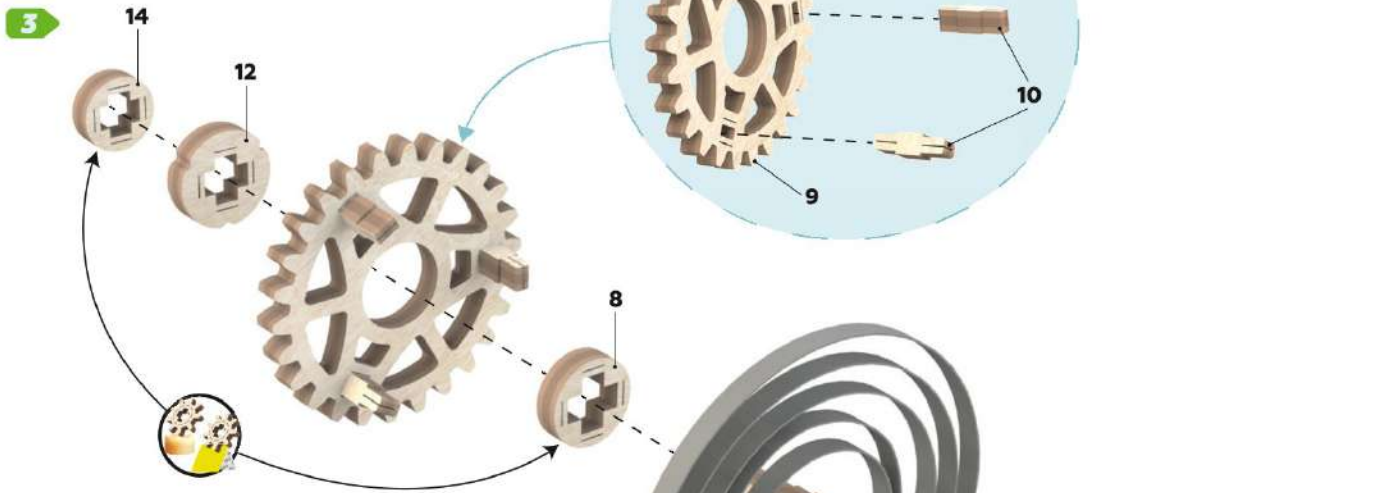
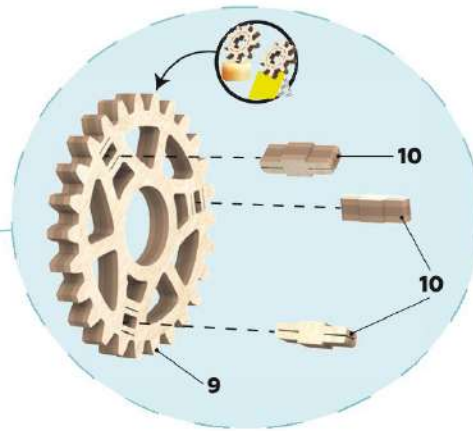
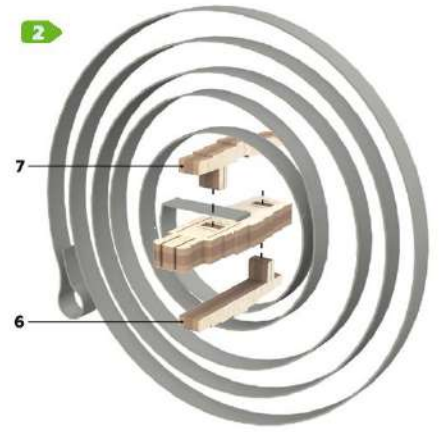
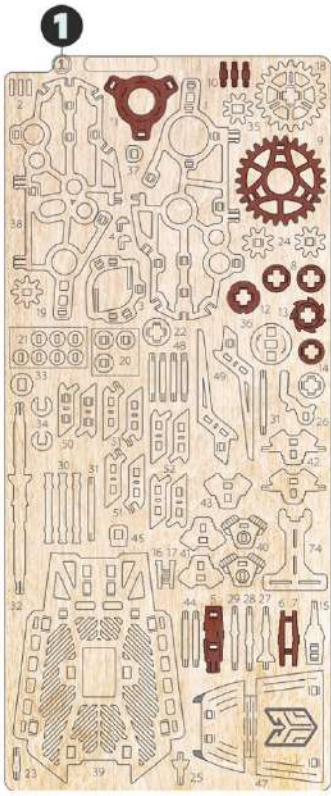

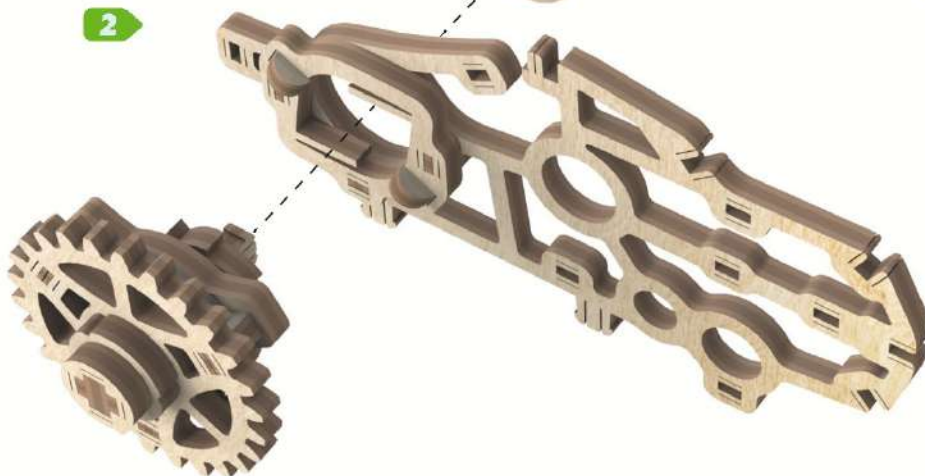
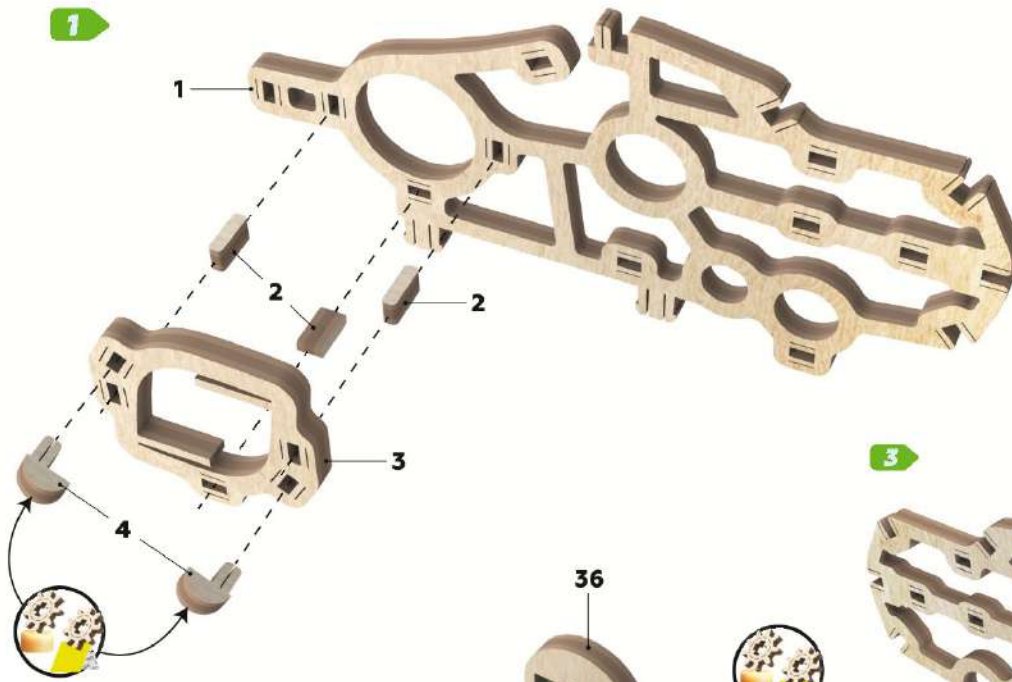



1

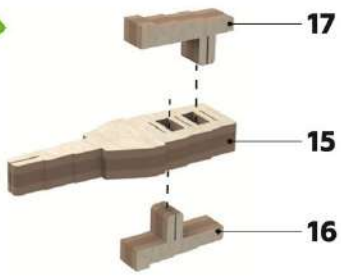

3



2

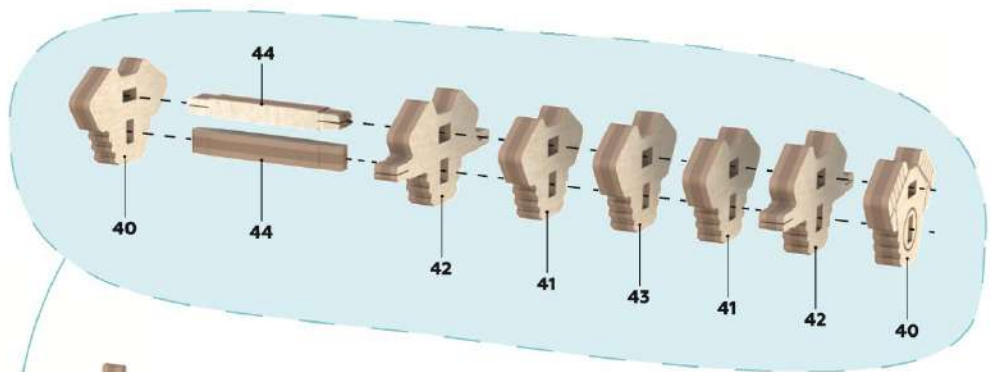
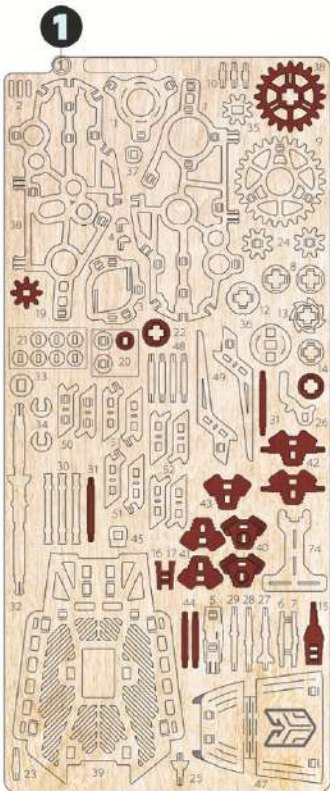
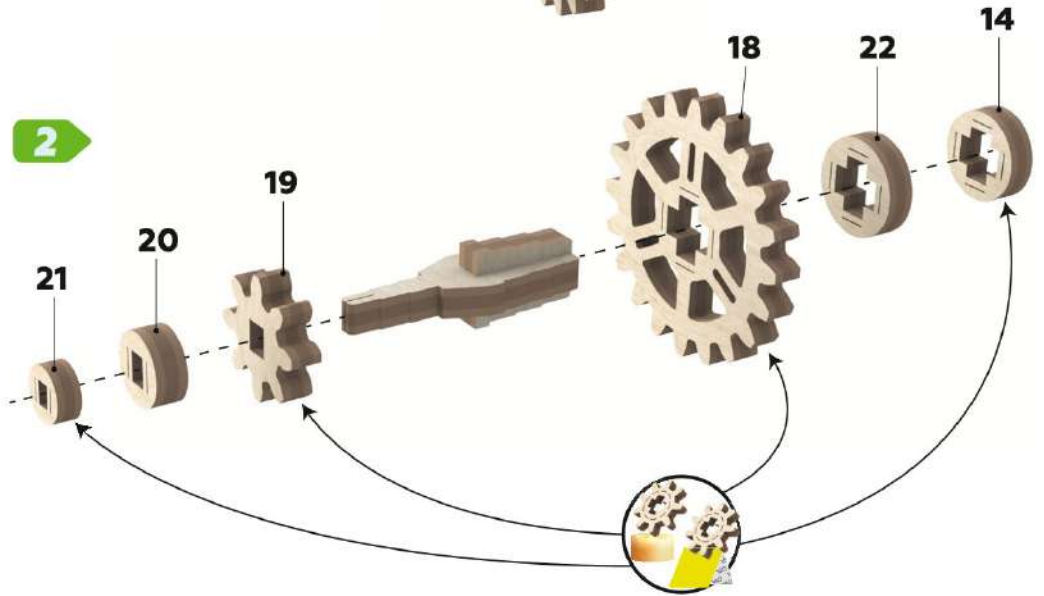

1

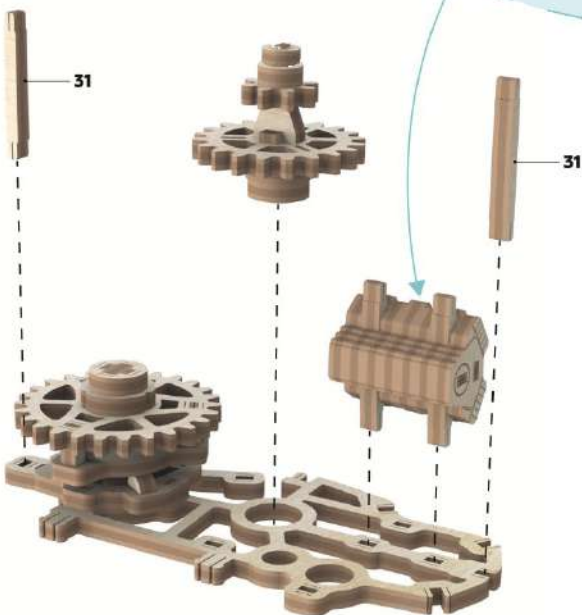

2



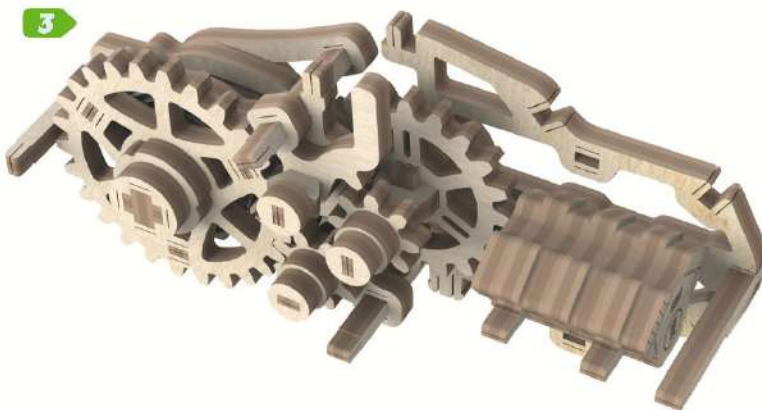
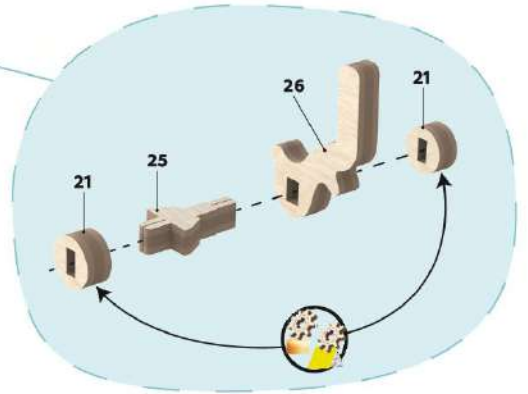
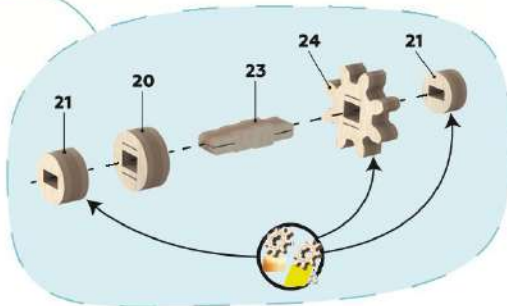
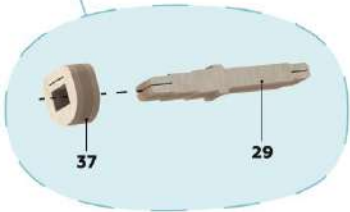
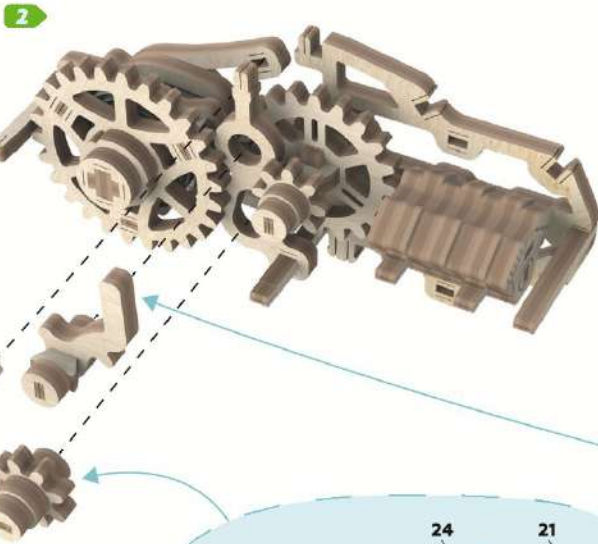
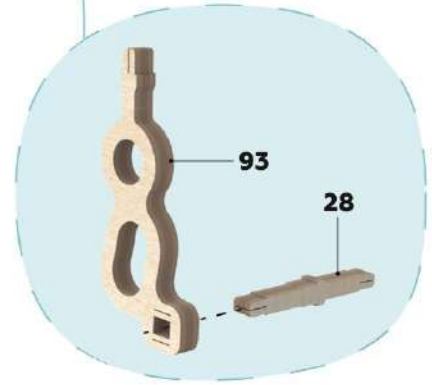
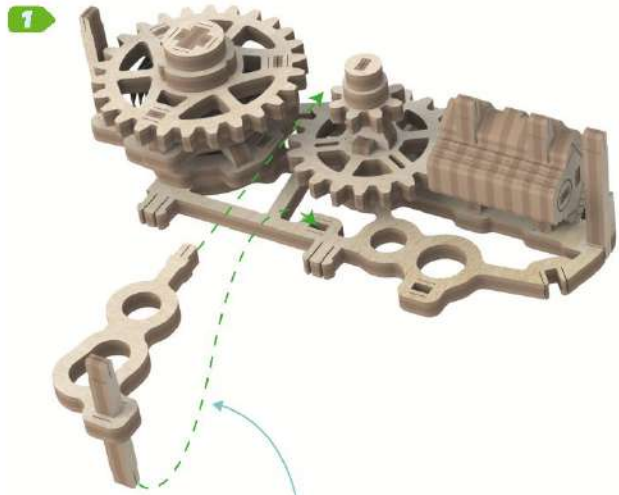
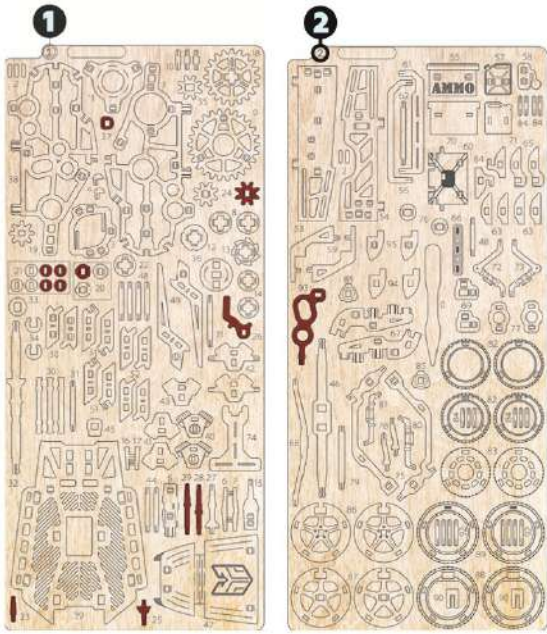



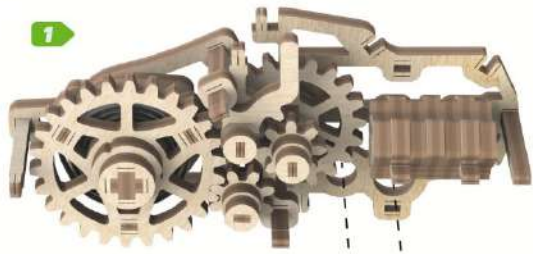

1

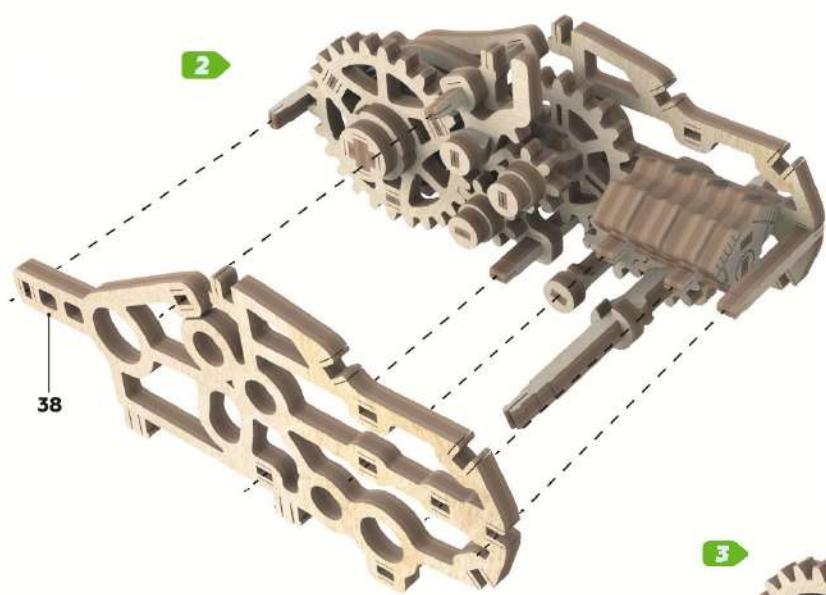
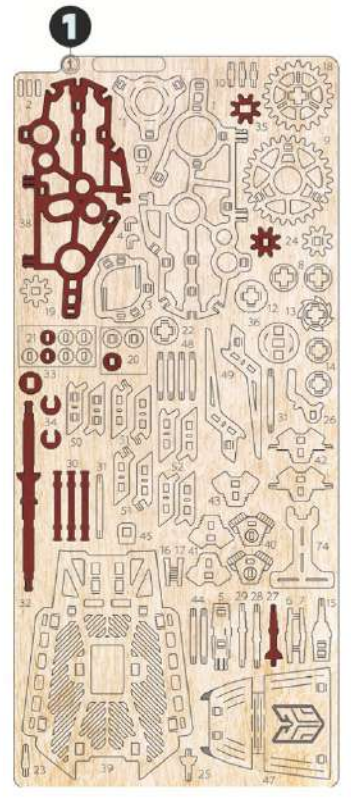
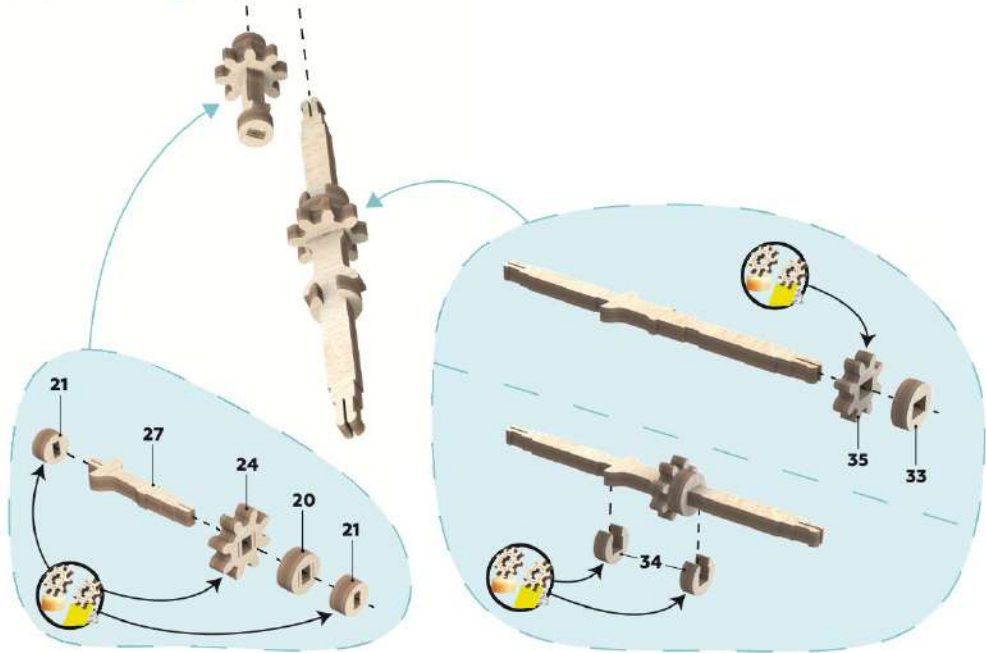

2

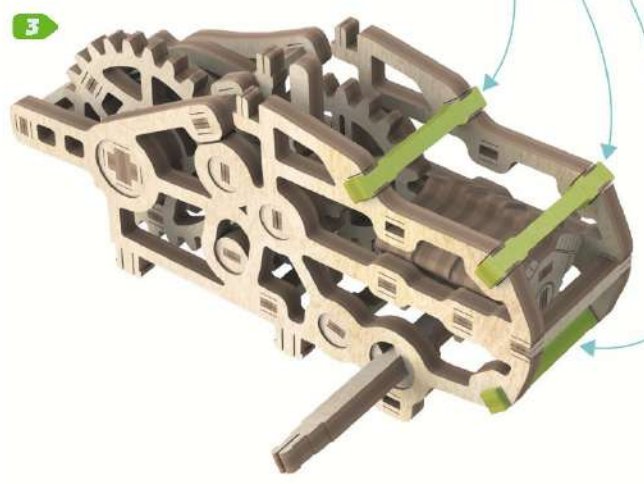
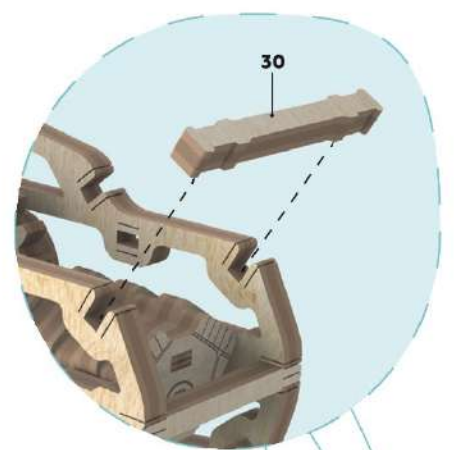

3



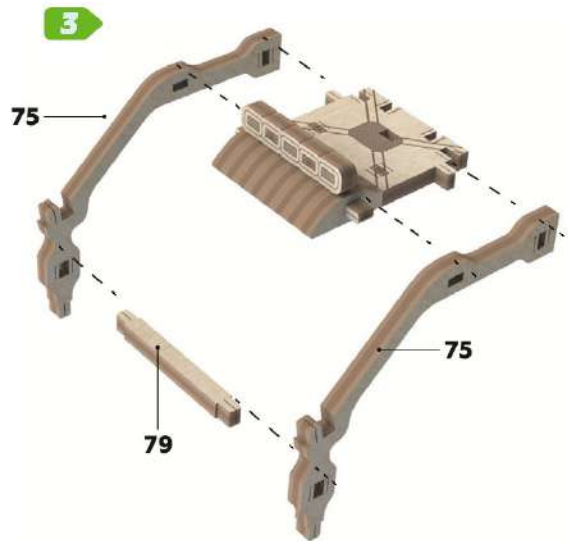
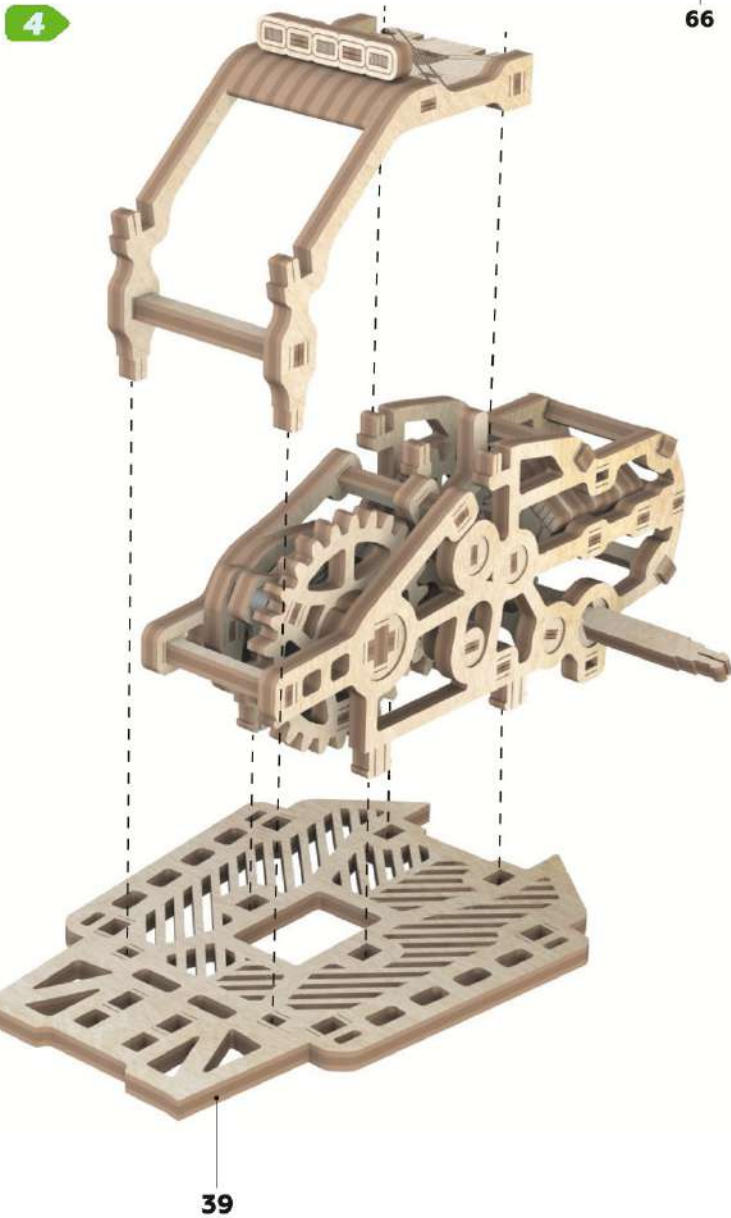
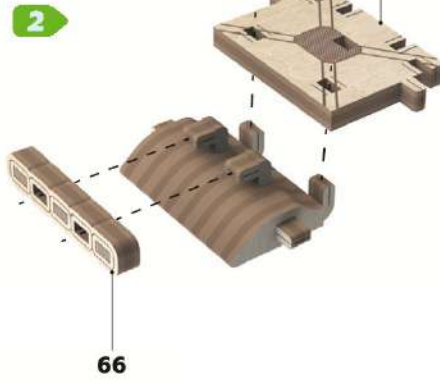
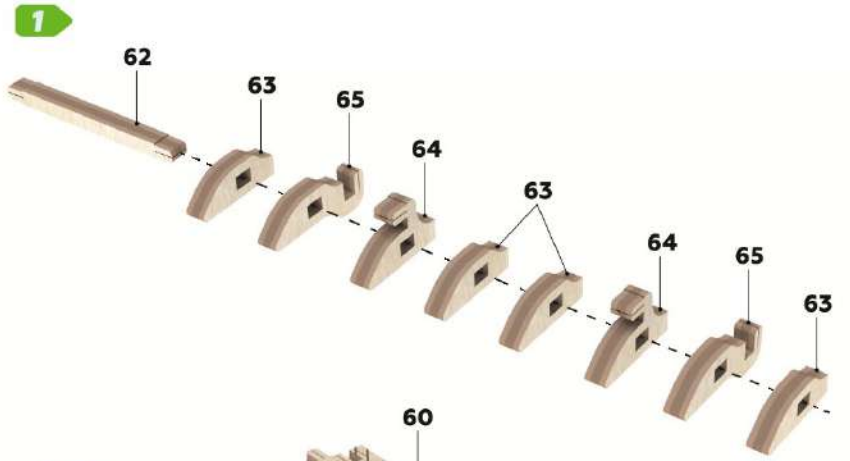
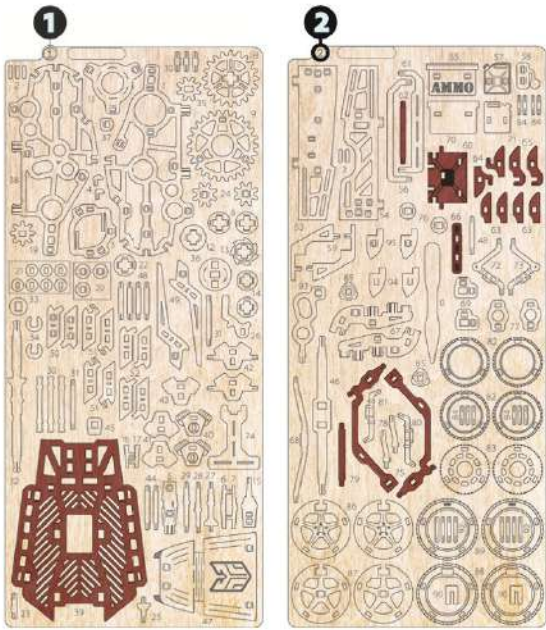

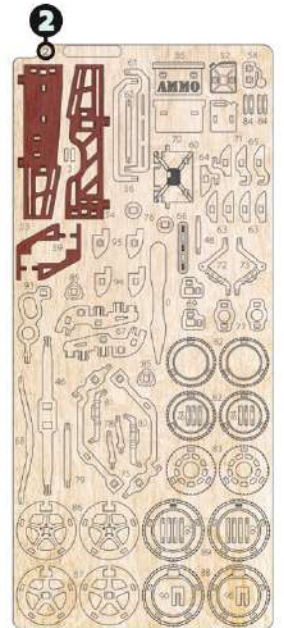
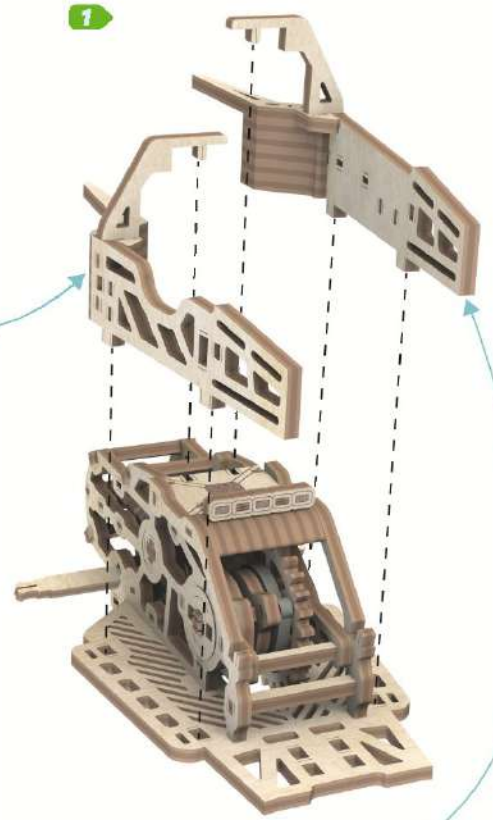
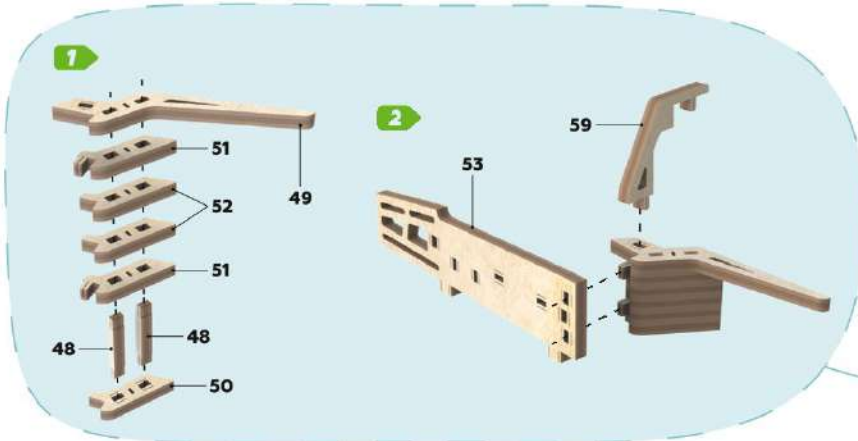
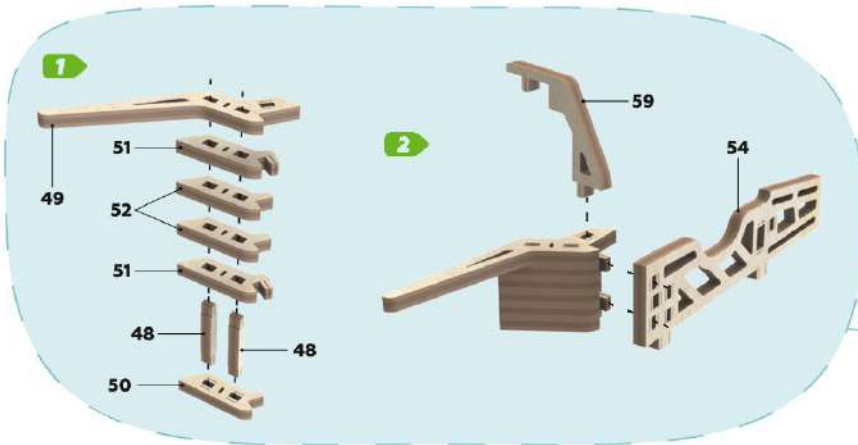



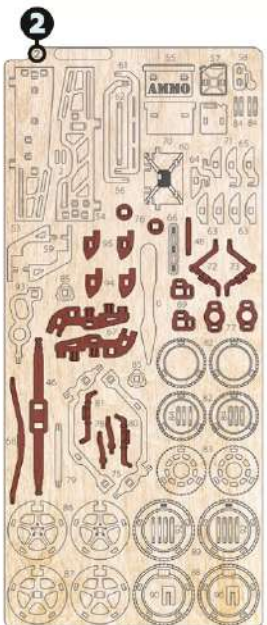
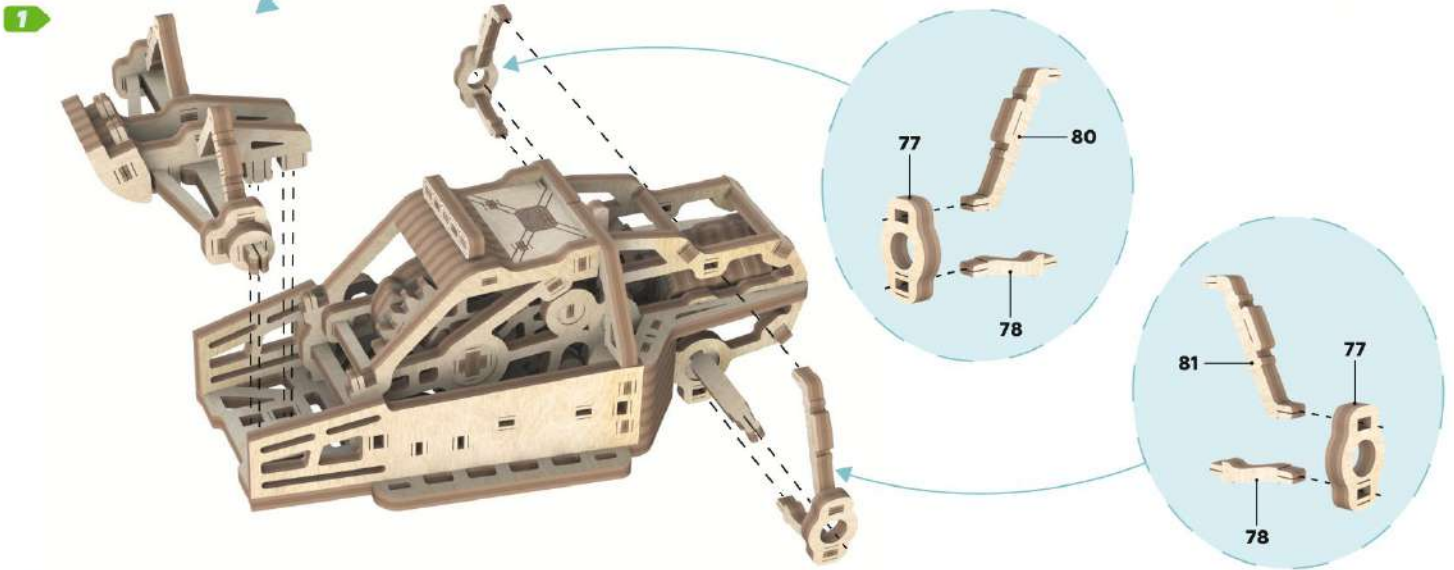
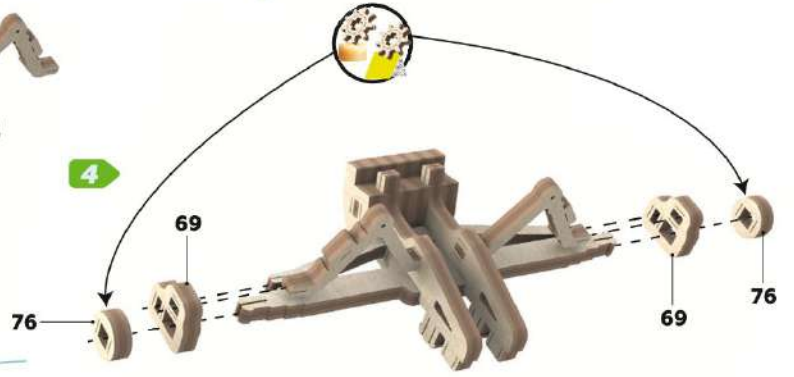
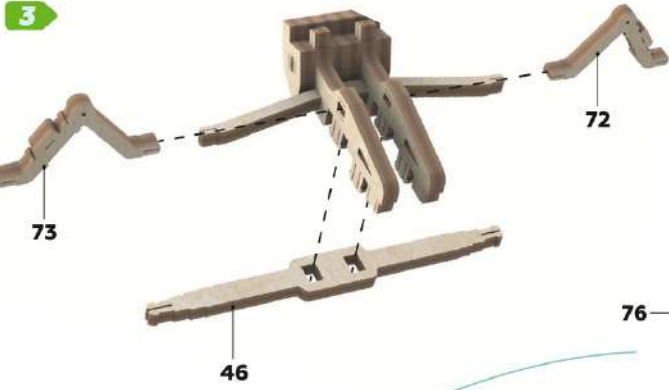
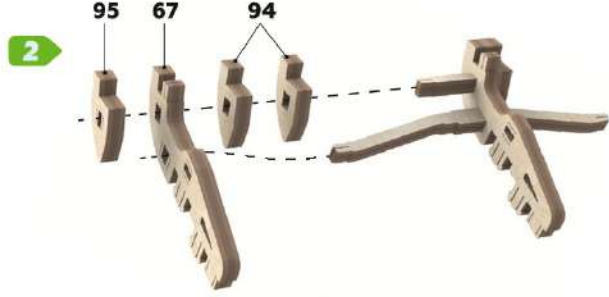
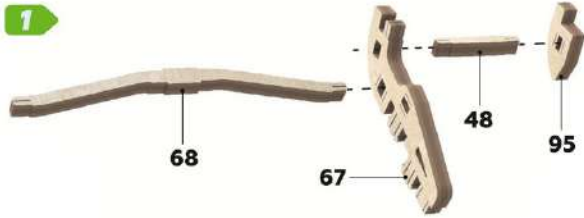

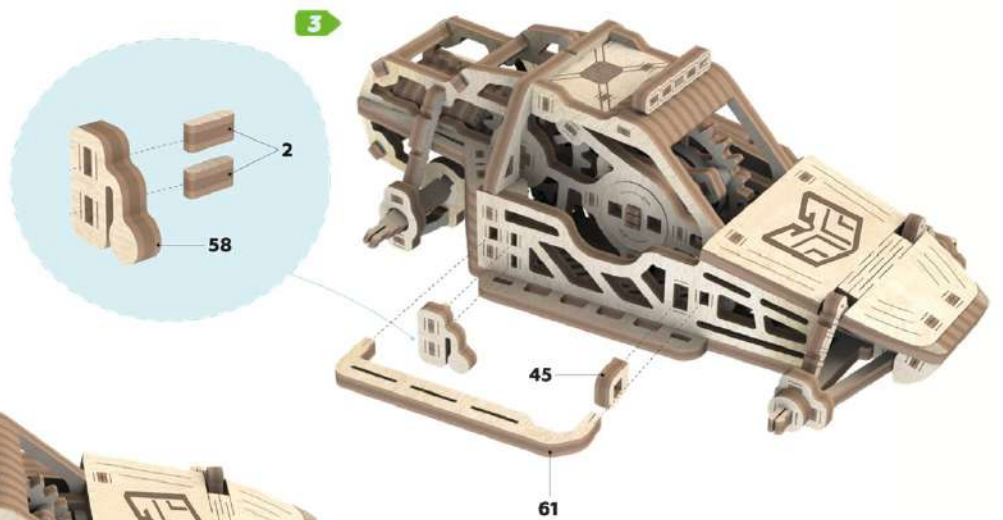
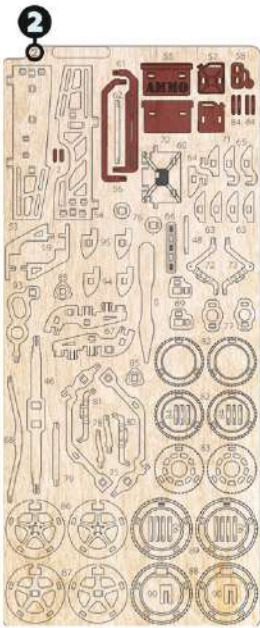
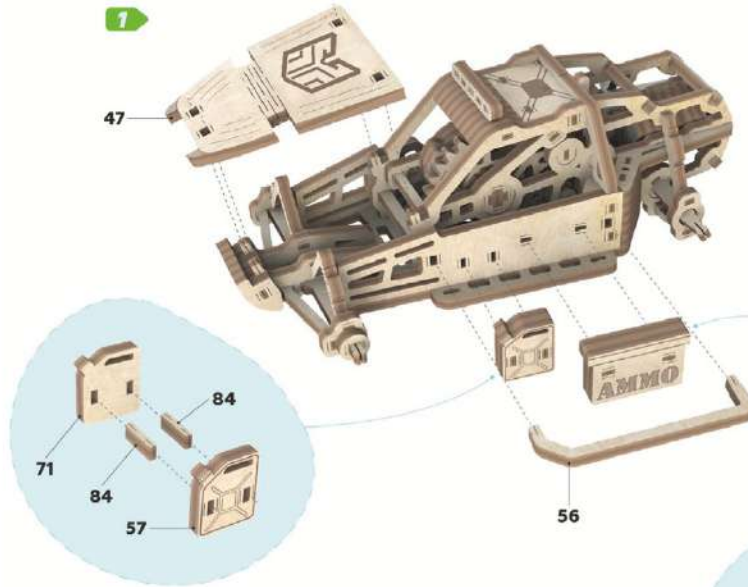



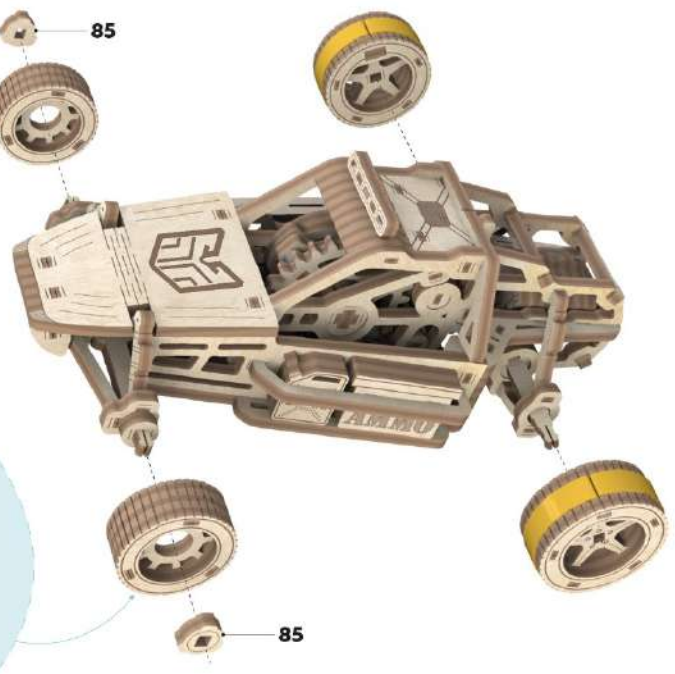
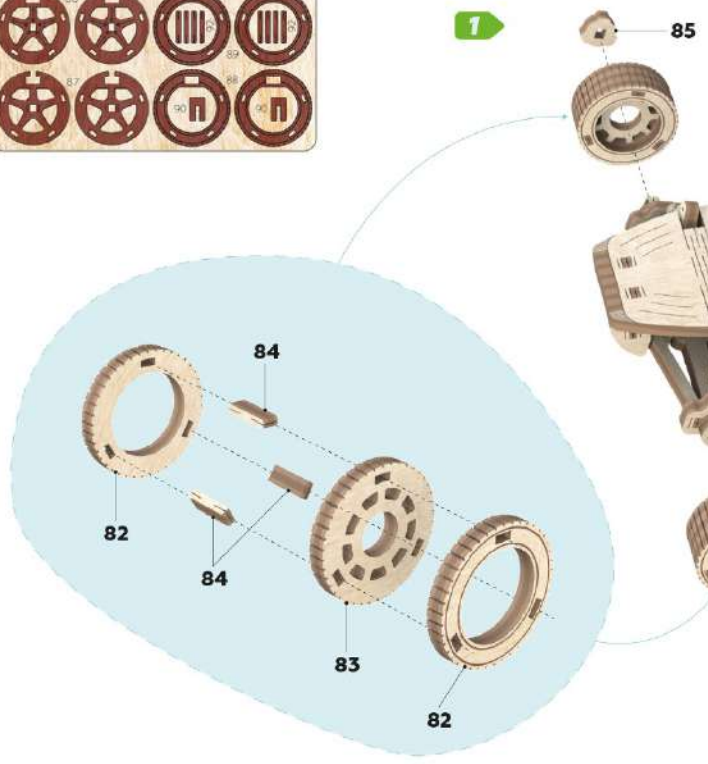
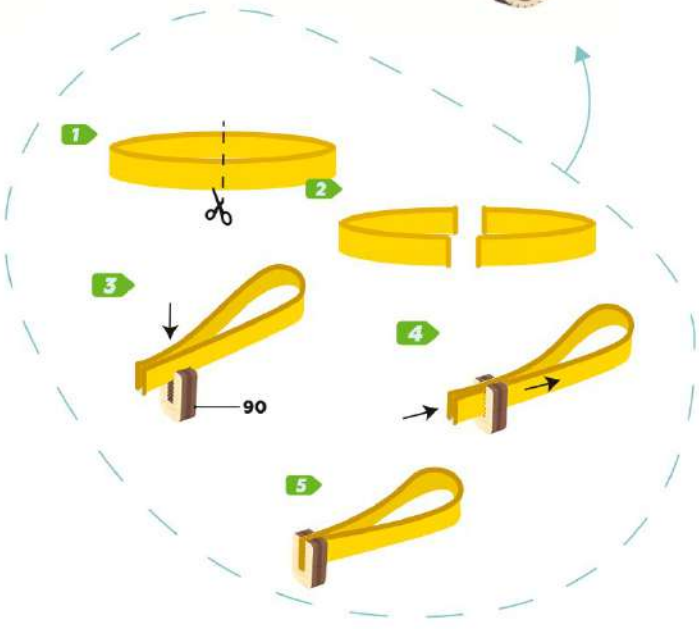
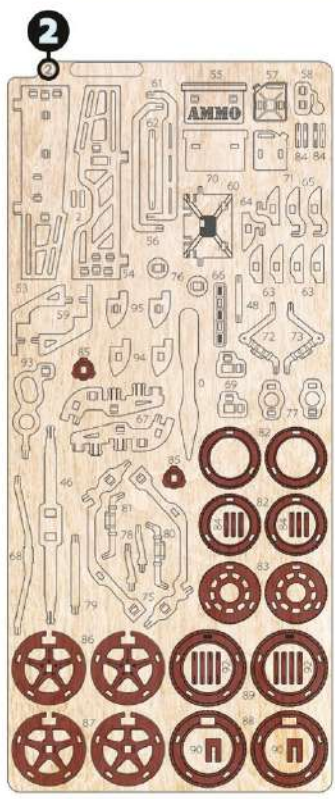
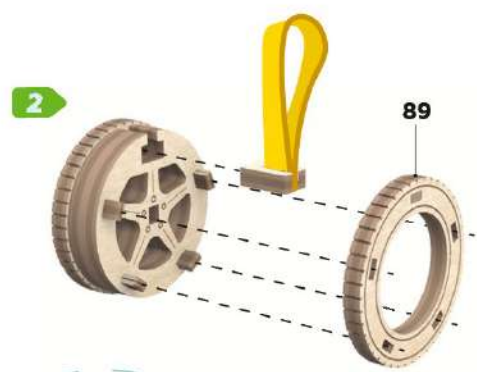
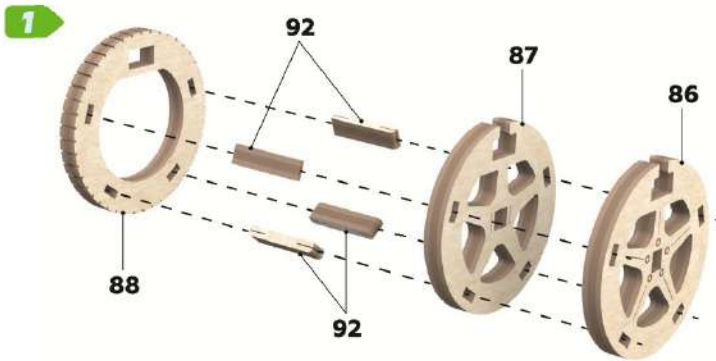

1

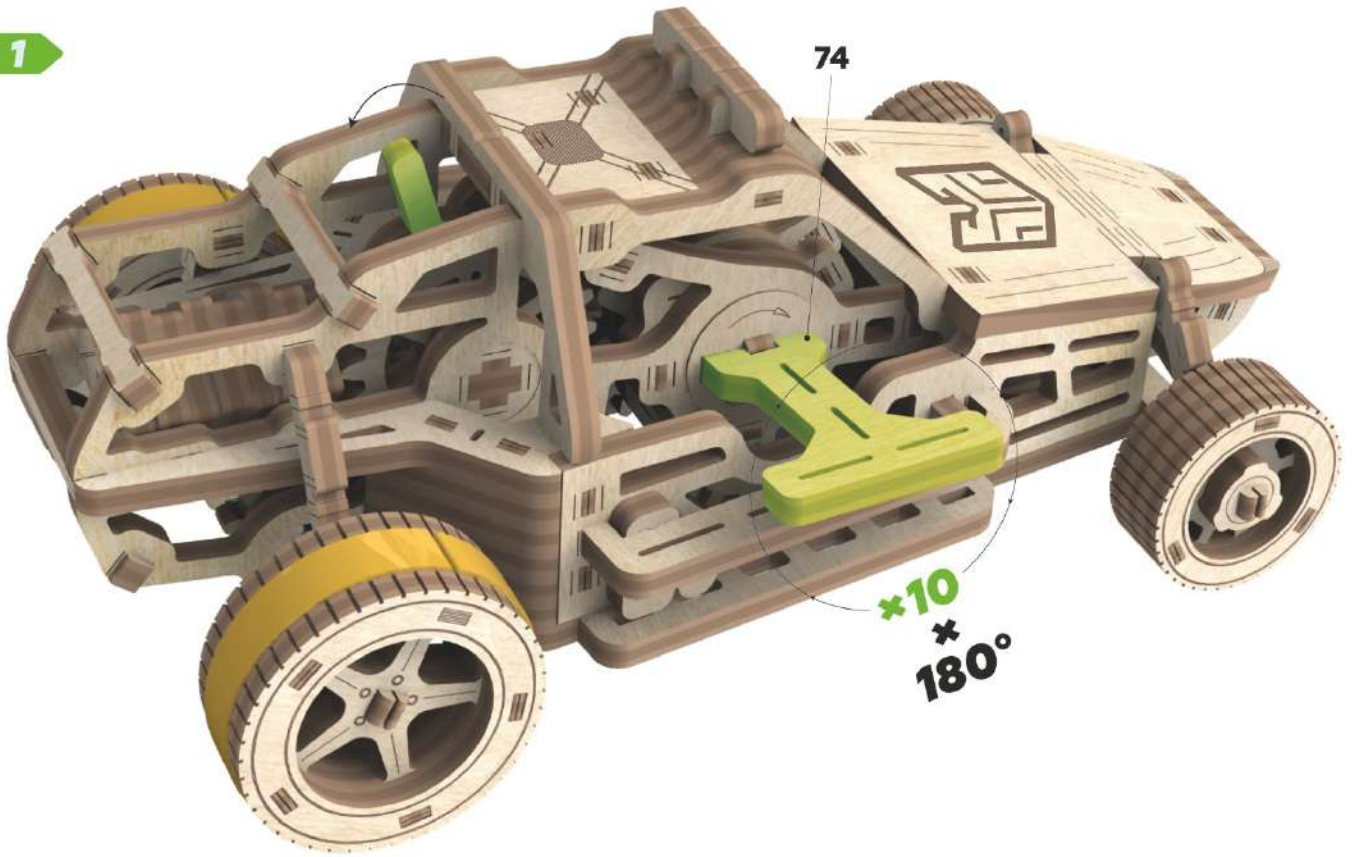

2

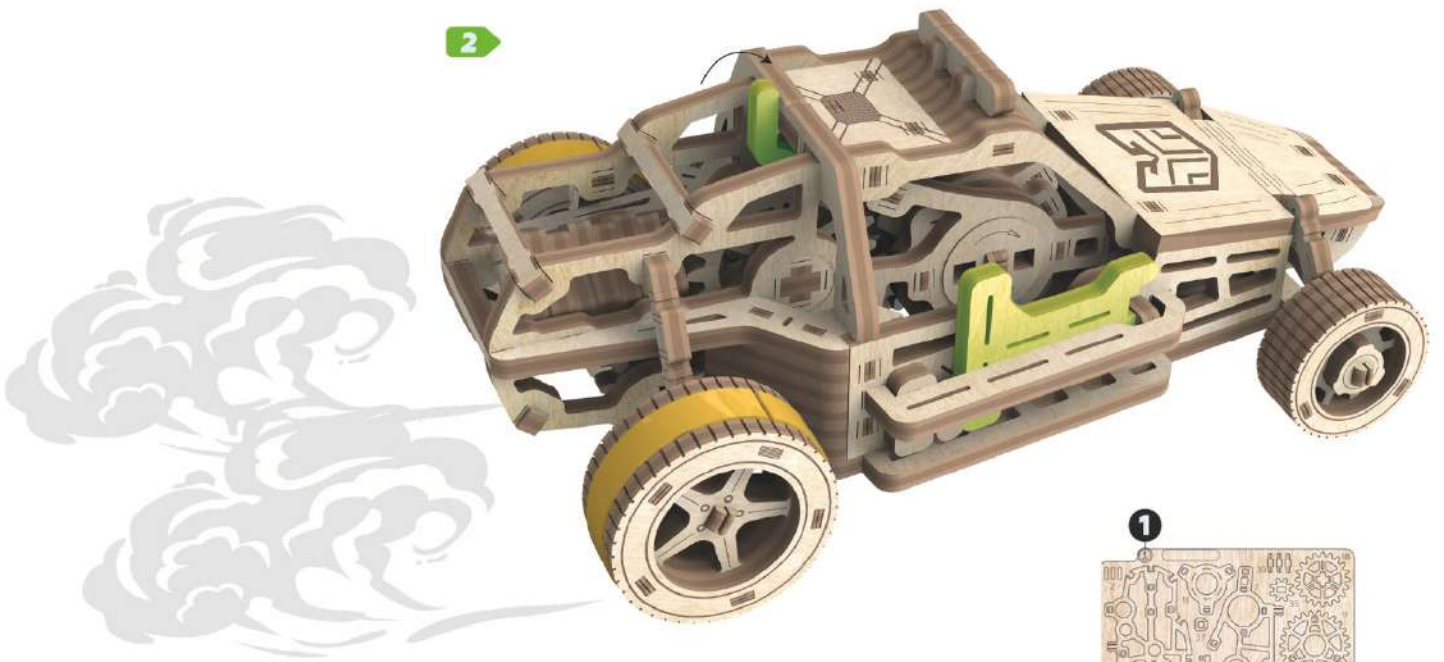

COMPLETE





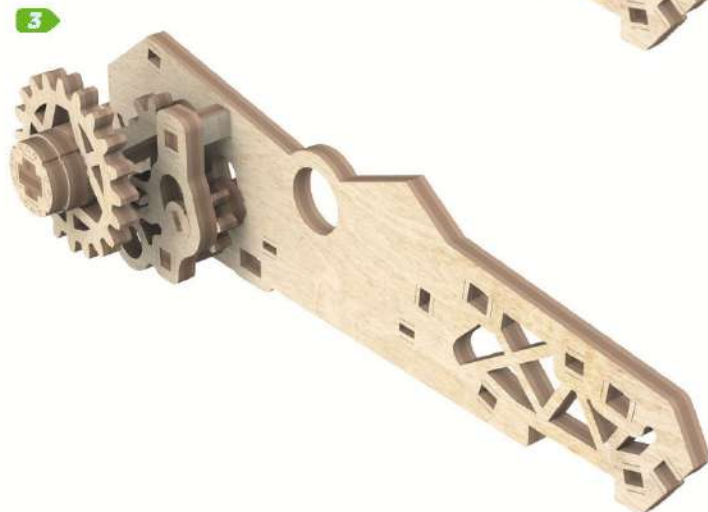
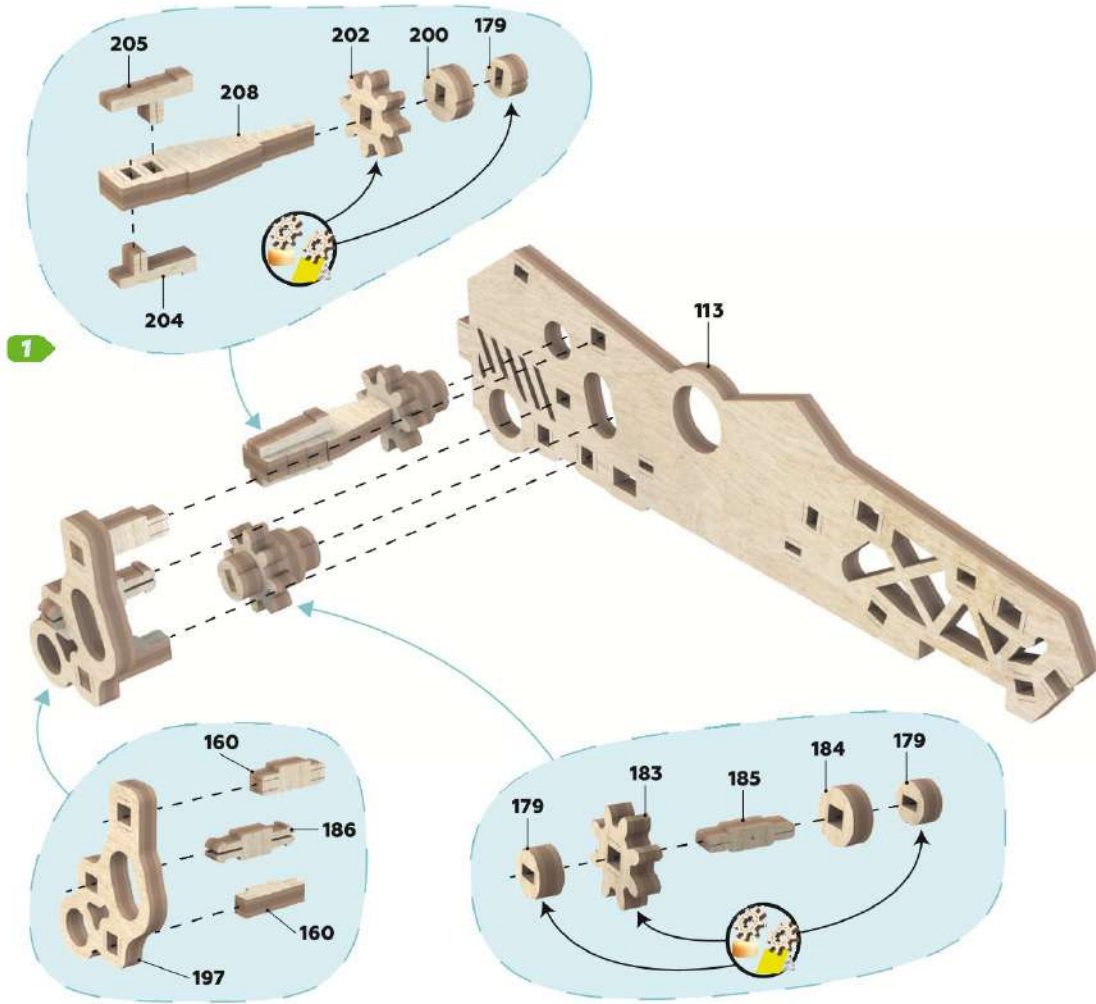

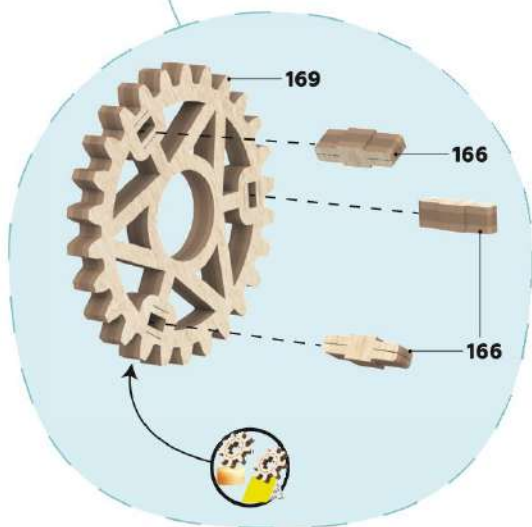
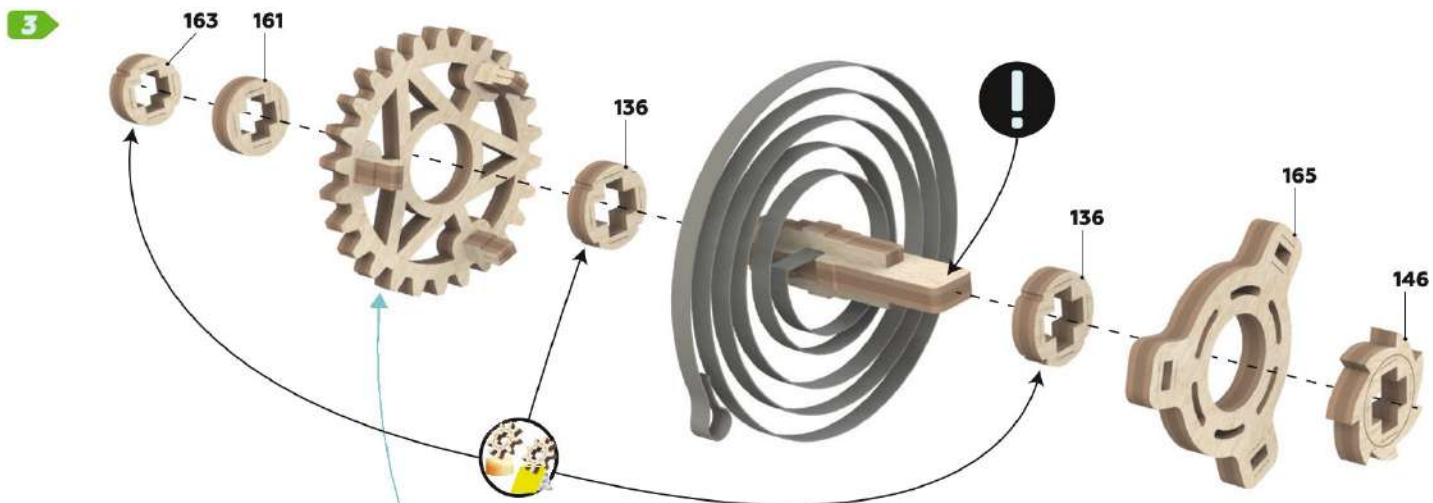
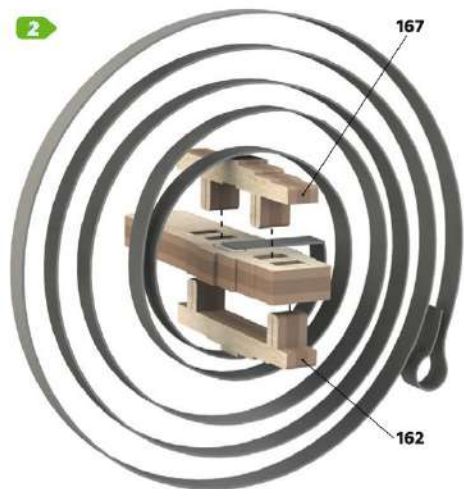



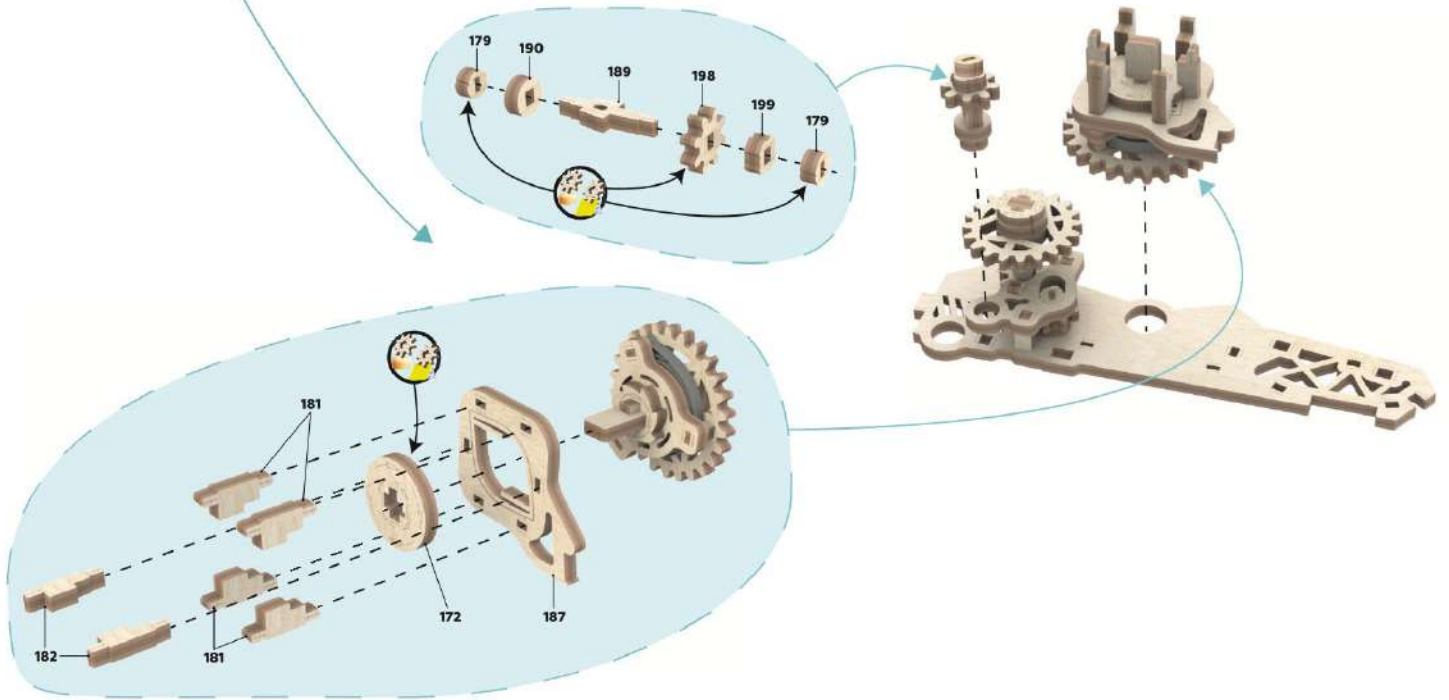

2

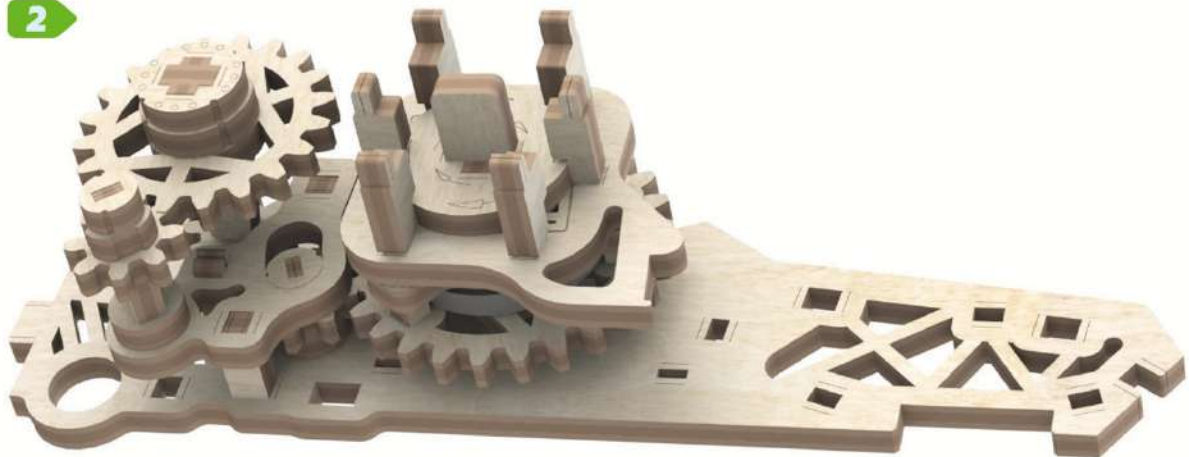

3



1

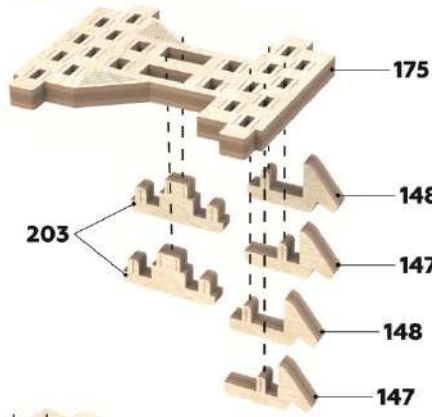

3

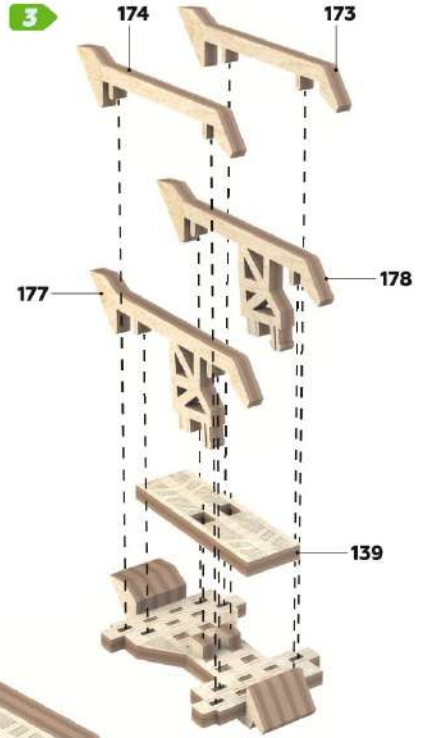

2

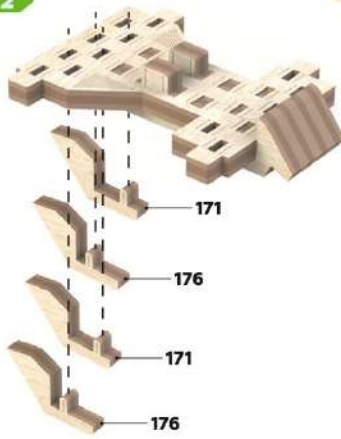

4



4



1

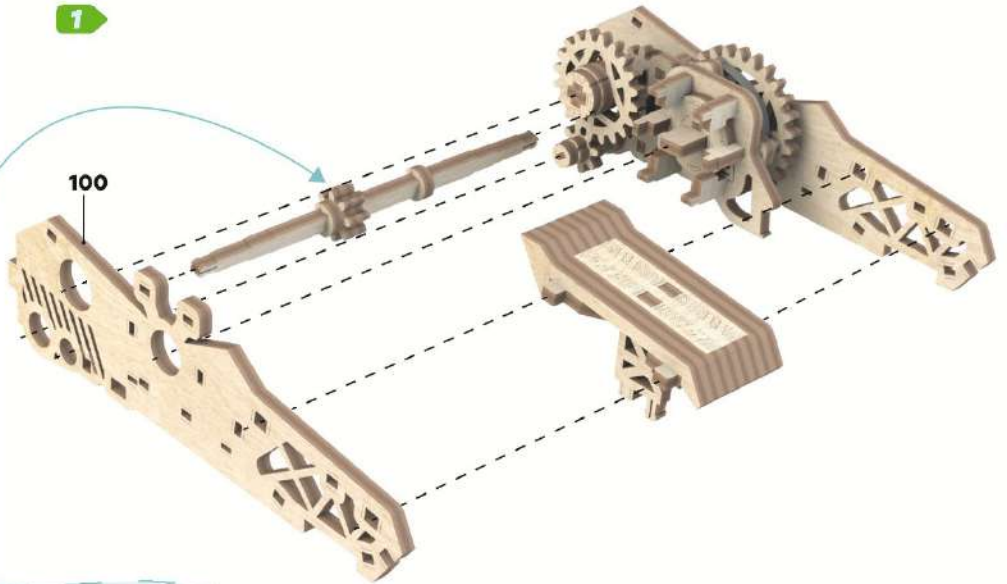

2

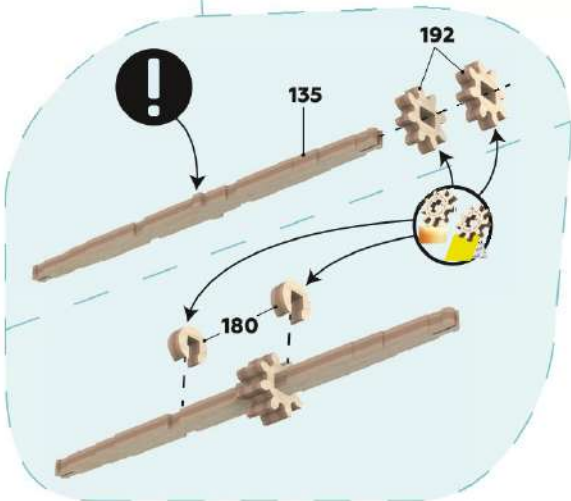



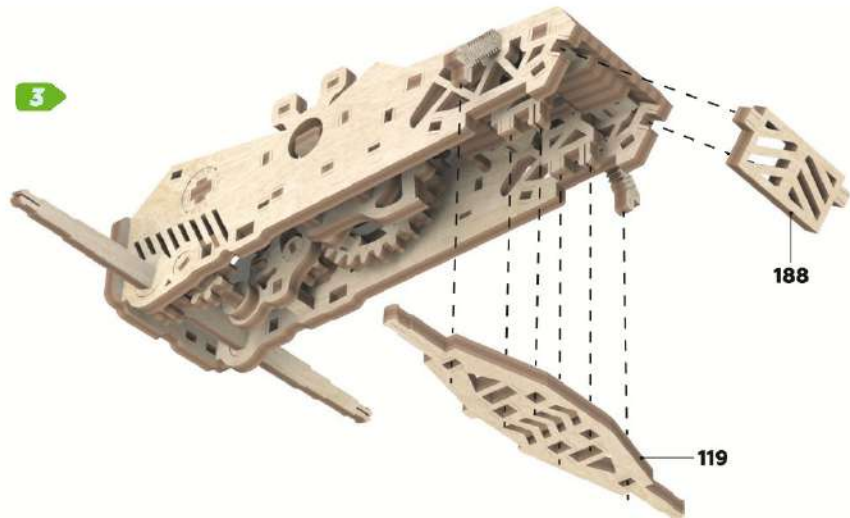
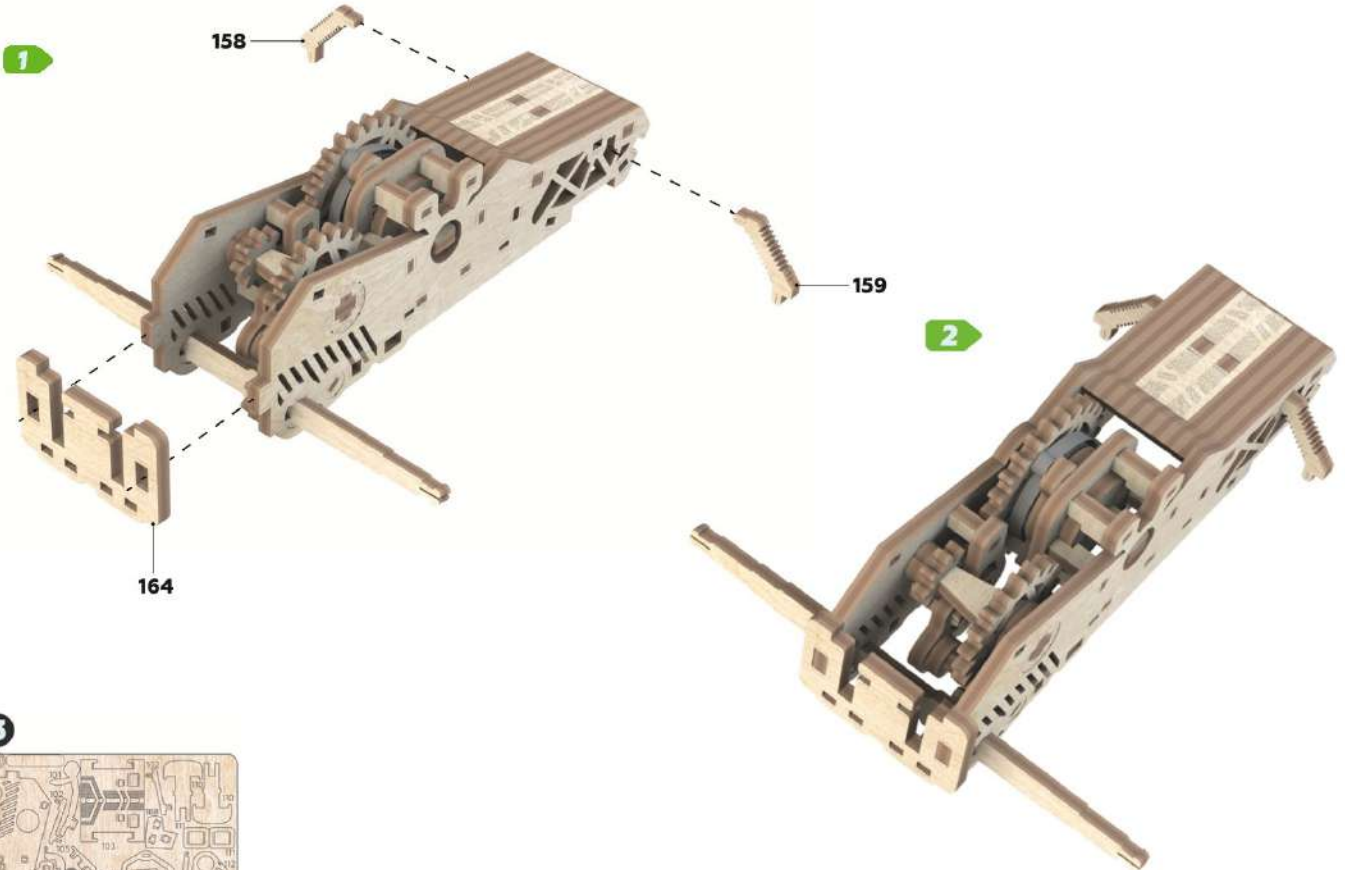

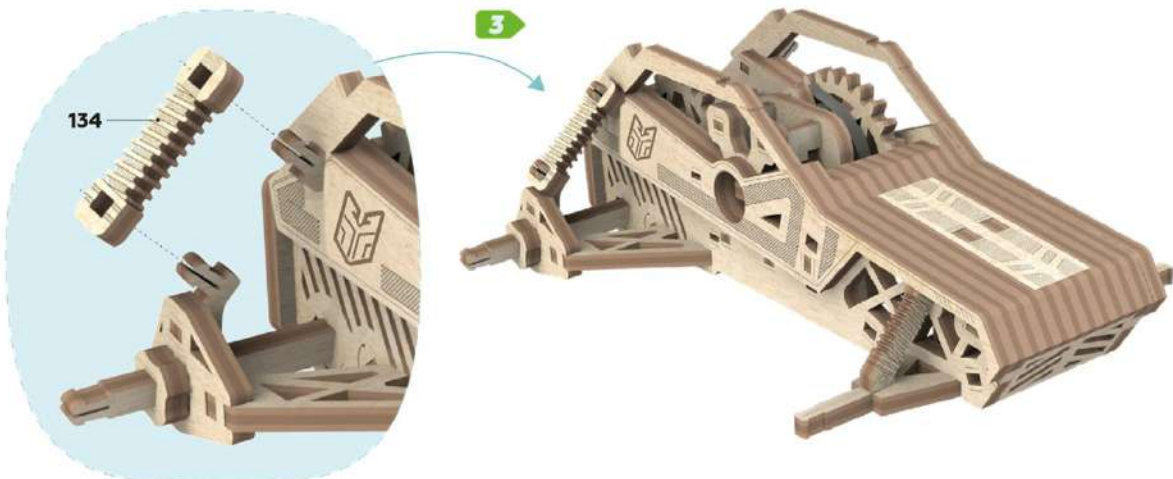
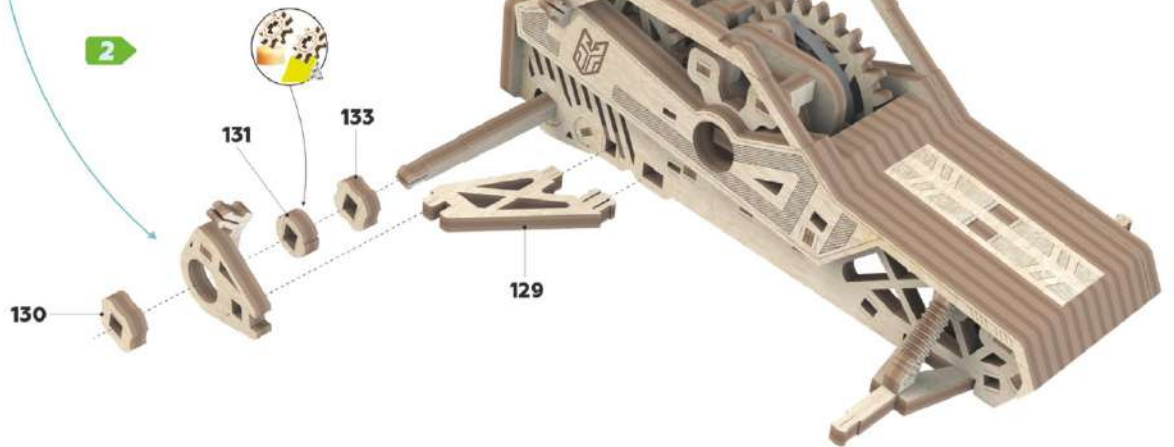
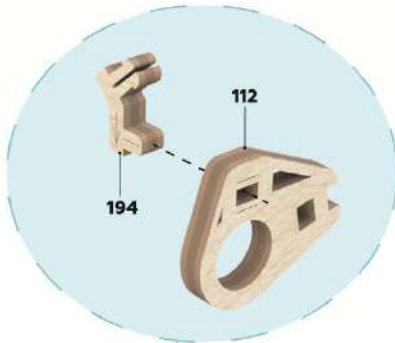
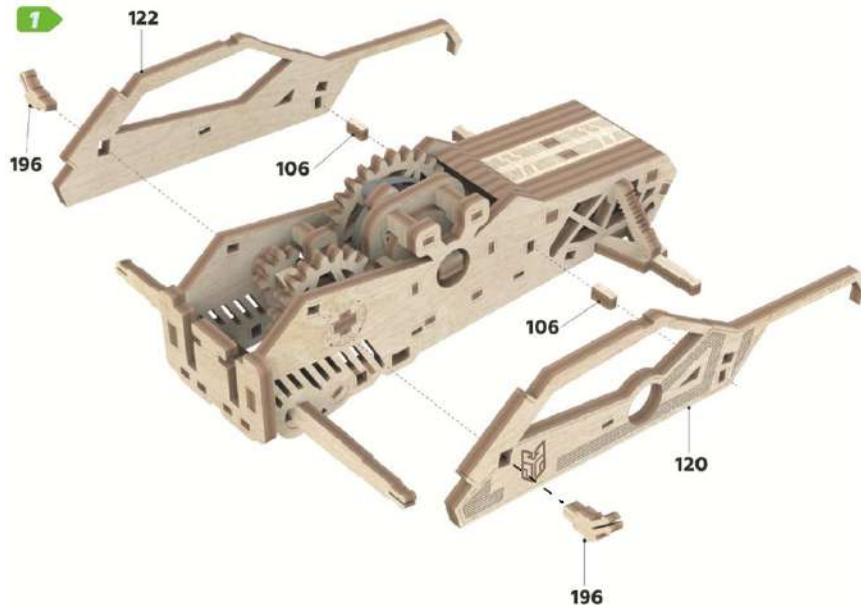



1

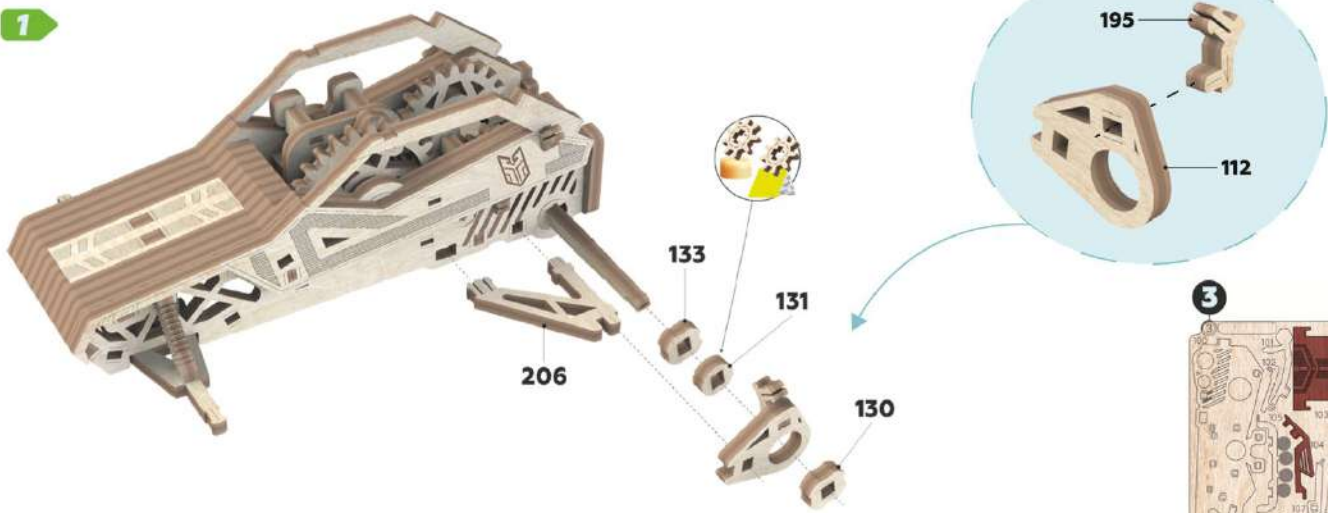

2

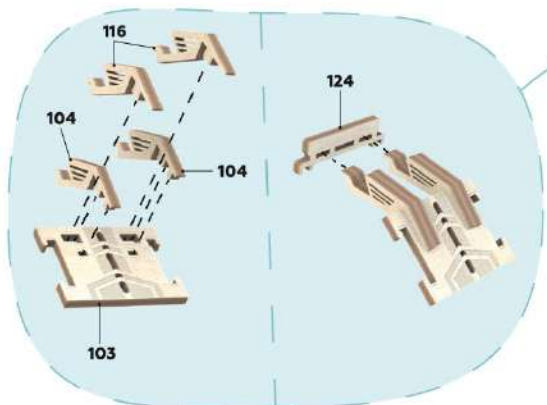
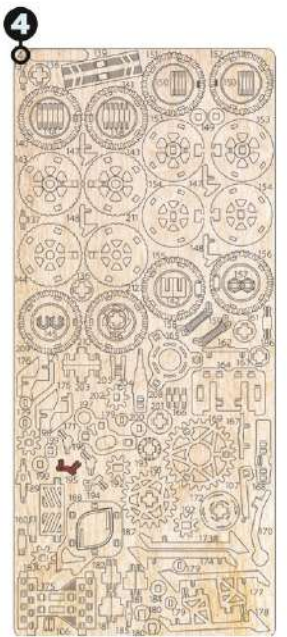
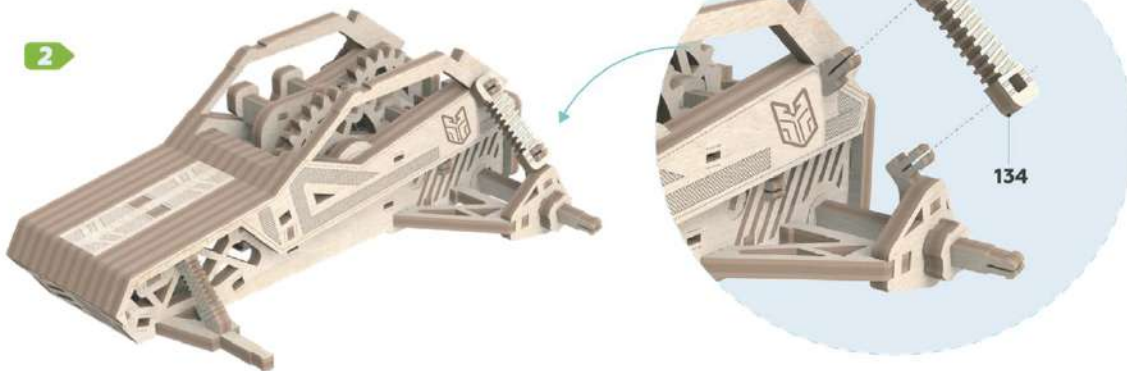

3

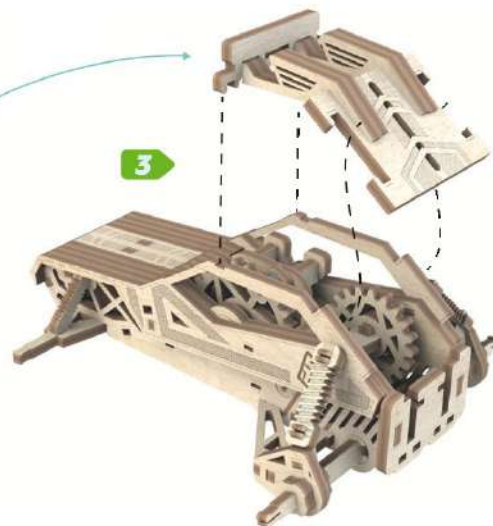

4



1

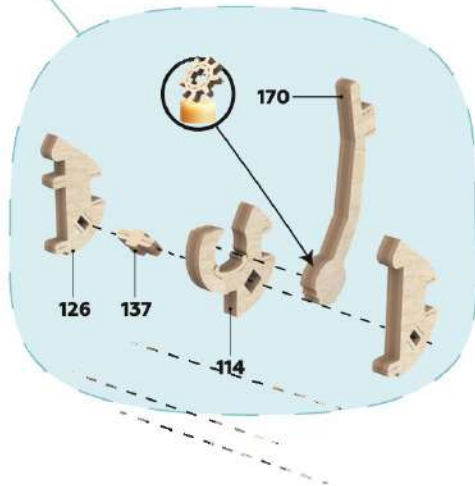
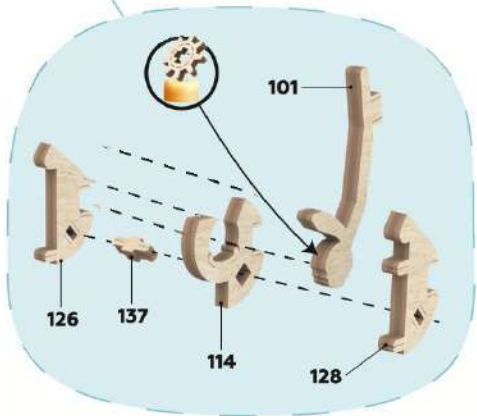
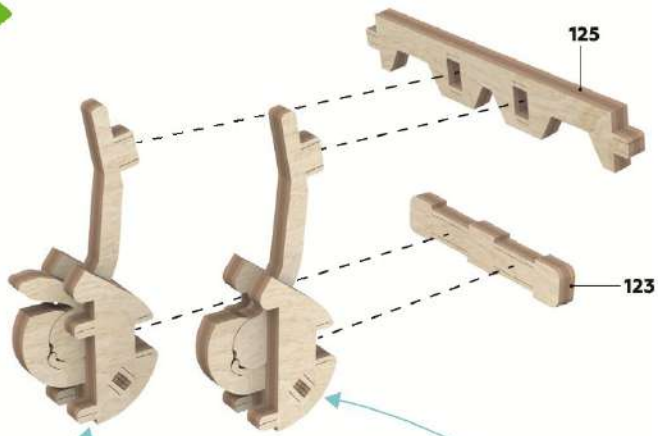

3



2



3

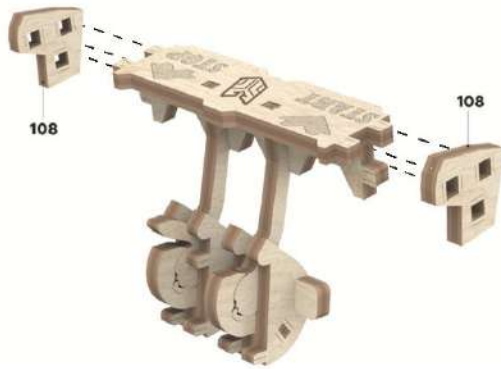

4



4

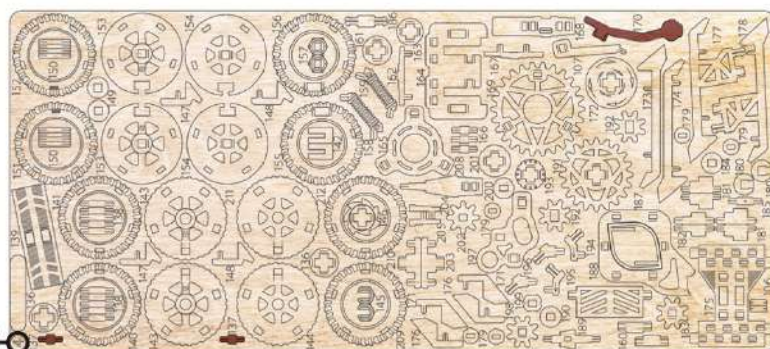



1



2

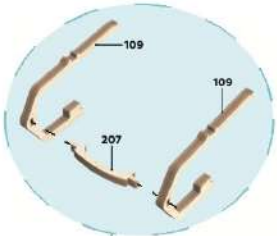
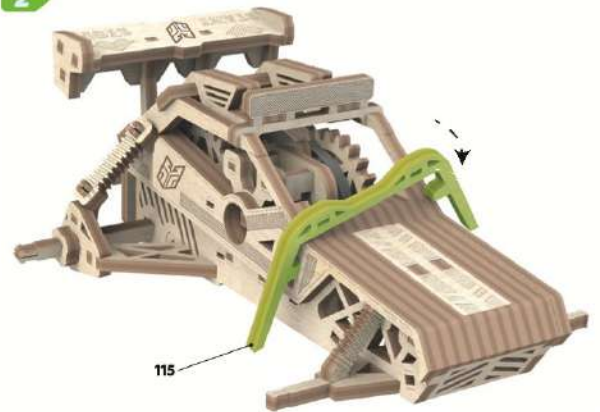

3

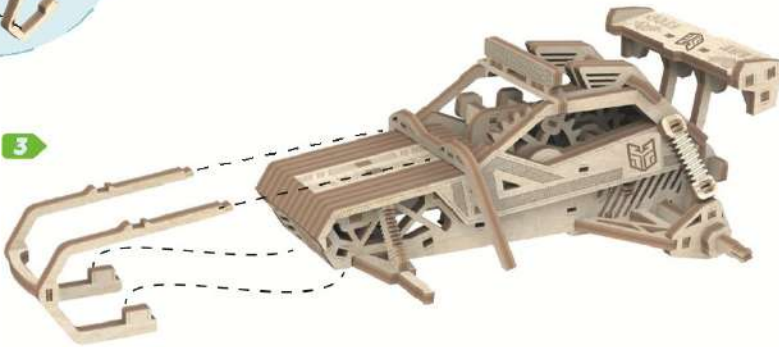

4

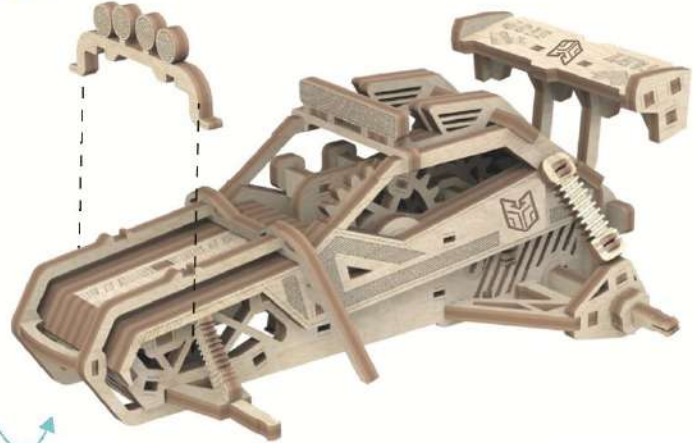

3



5



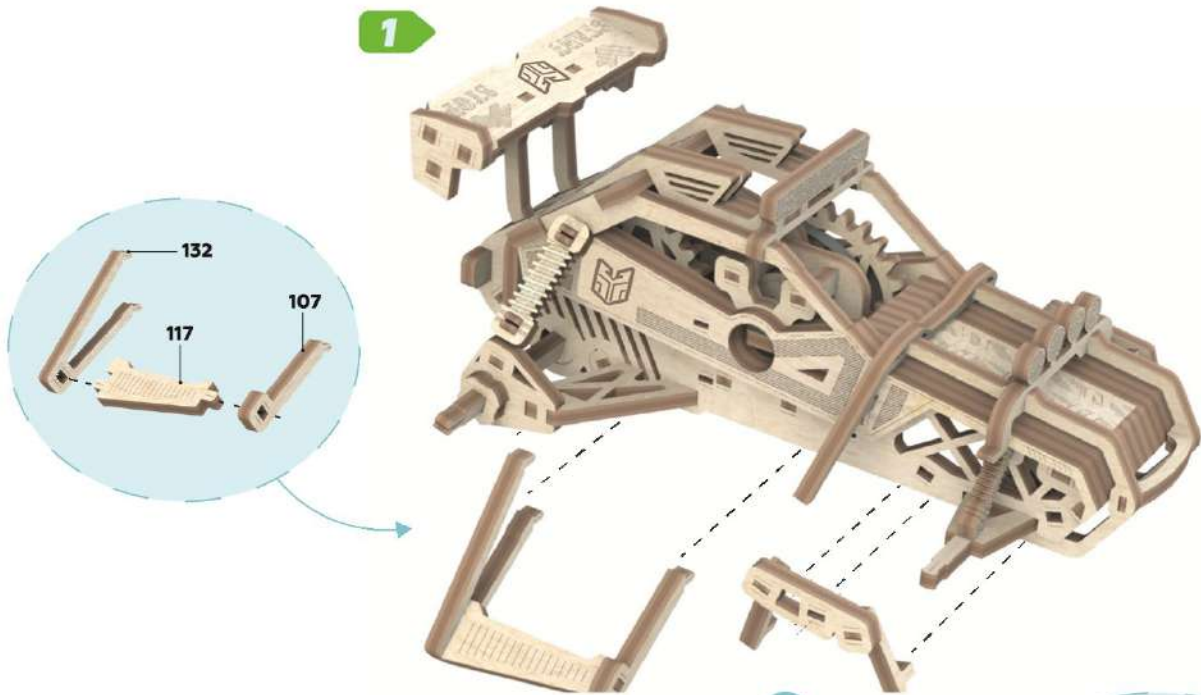

x2

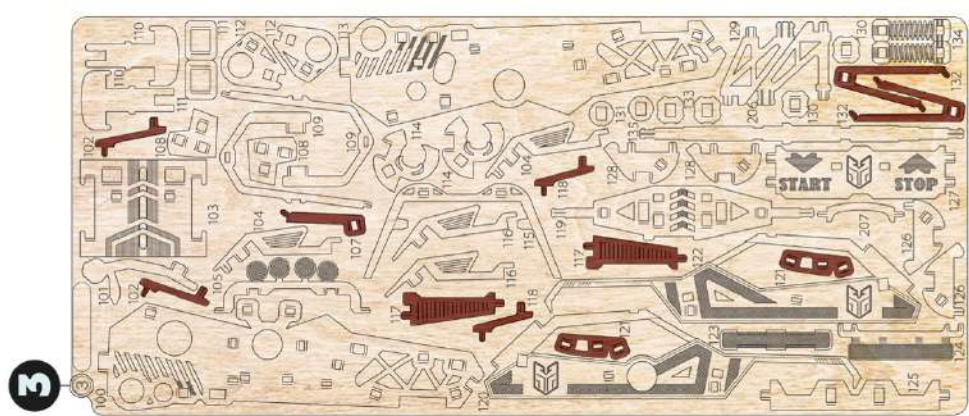
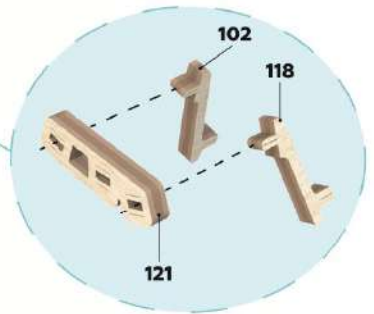



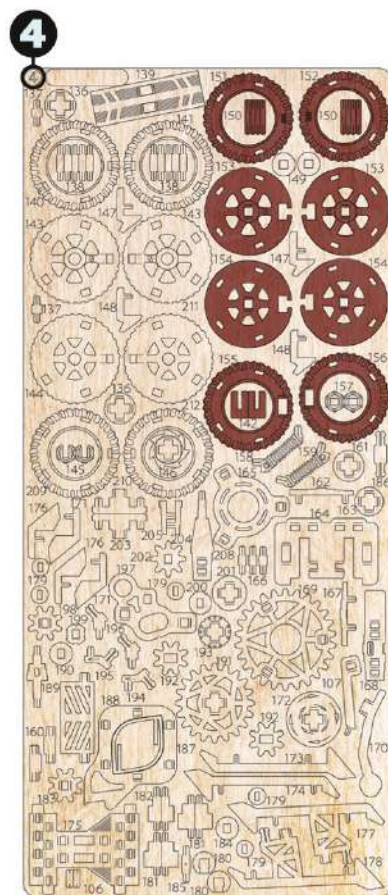
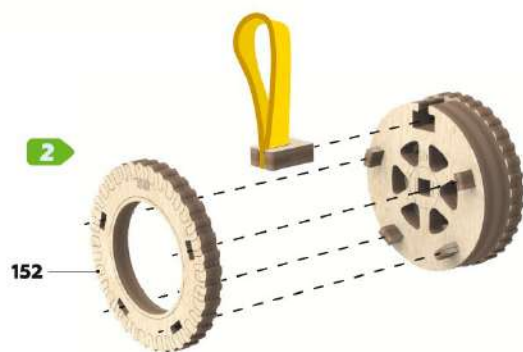
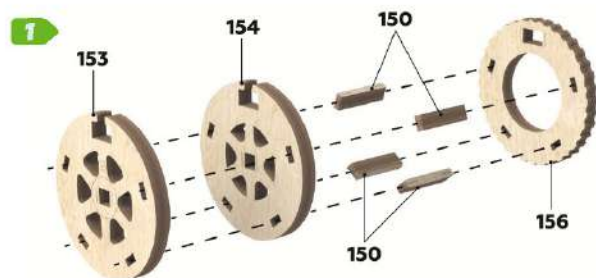
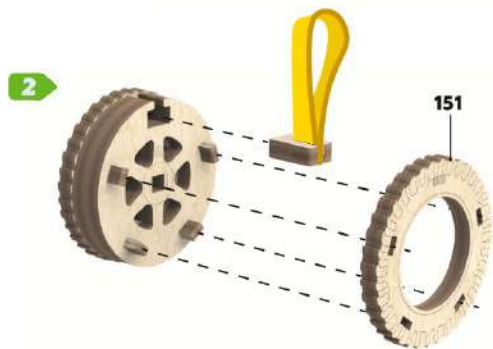
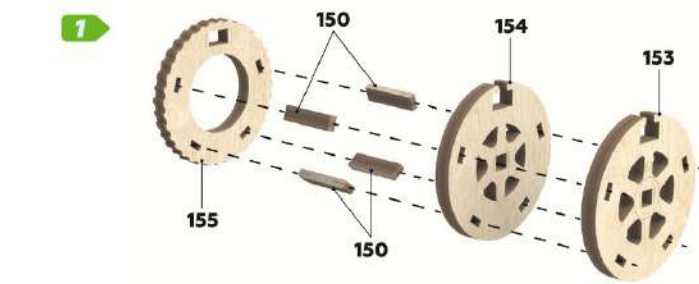
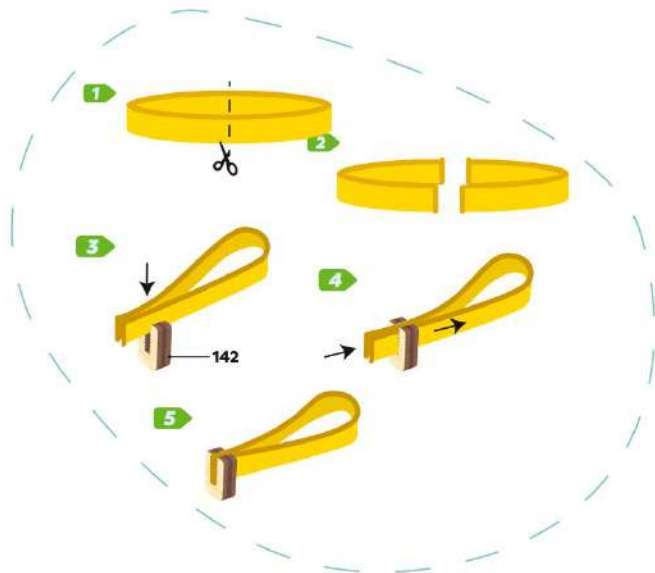

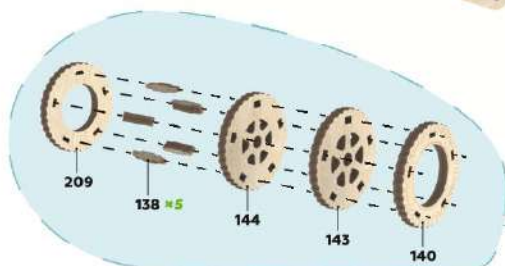
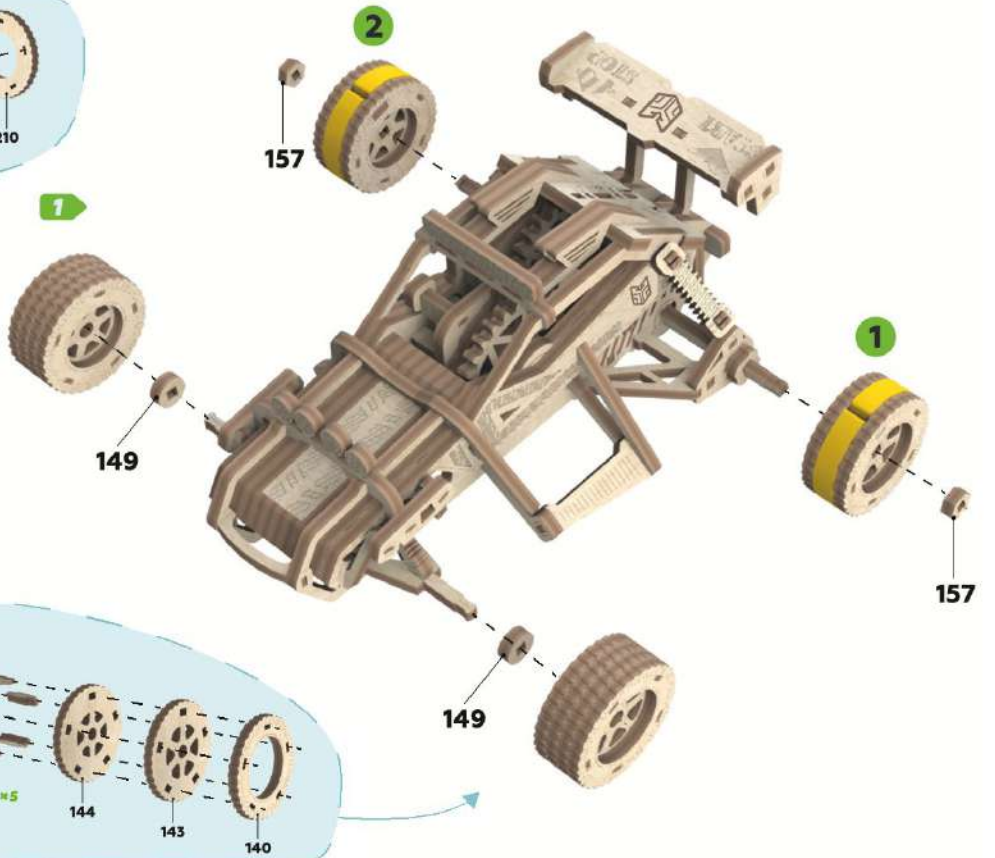
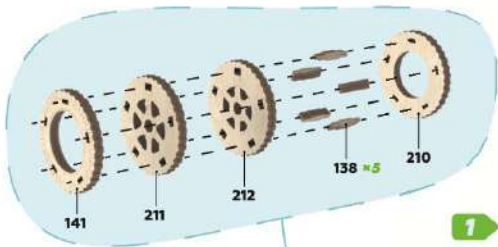
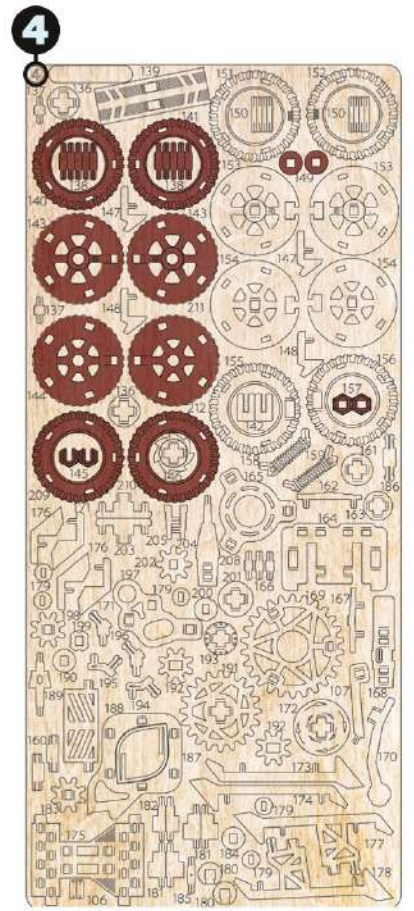
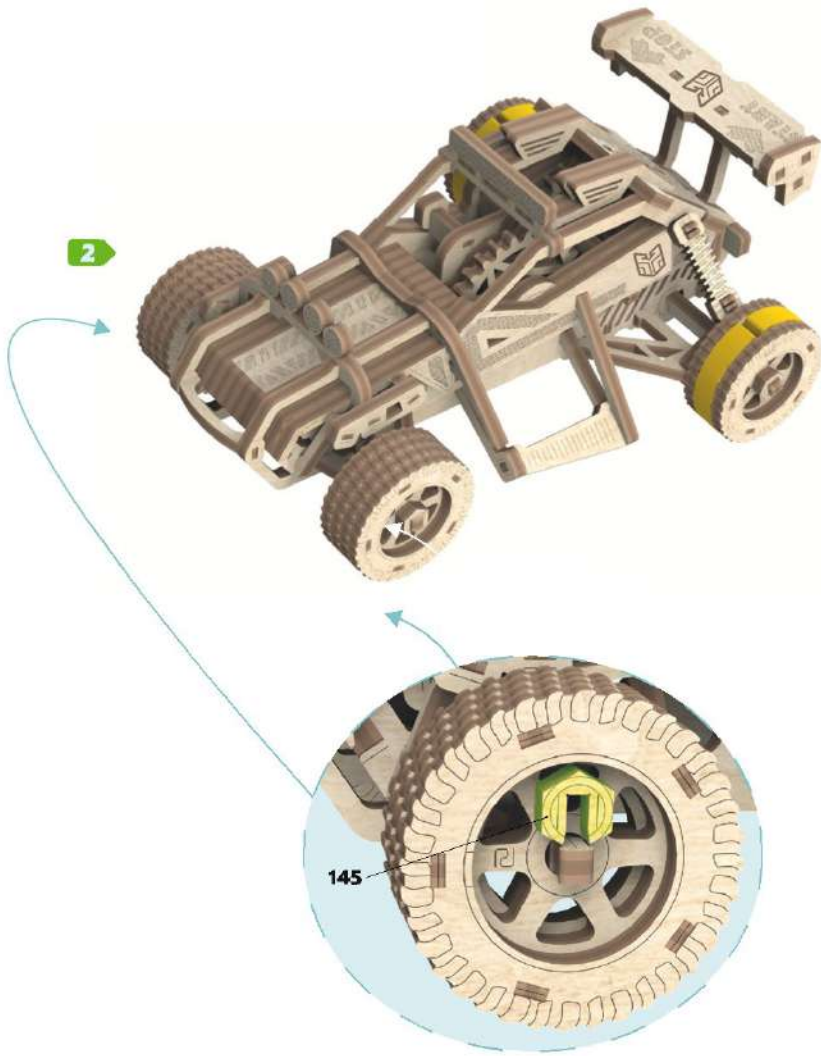



3



1

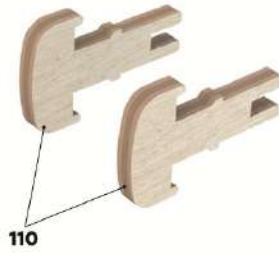

2



4

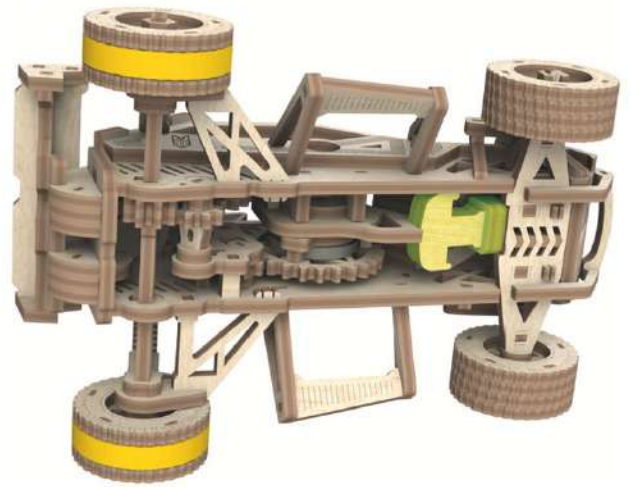

3

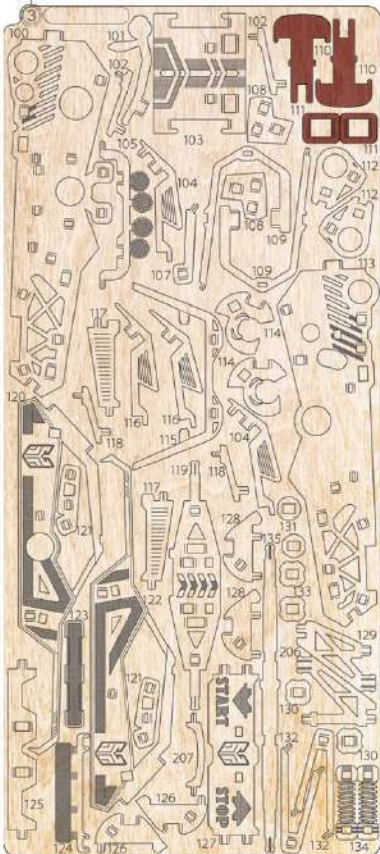

## Собирайте также:

Родстер 007

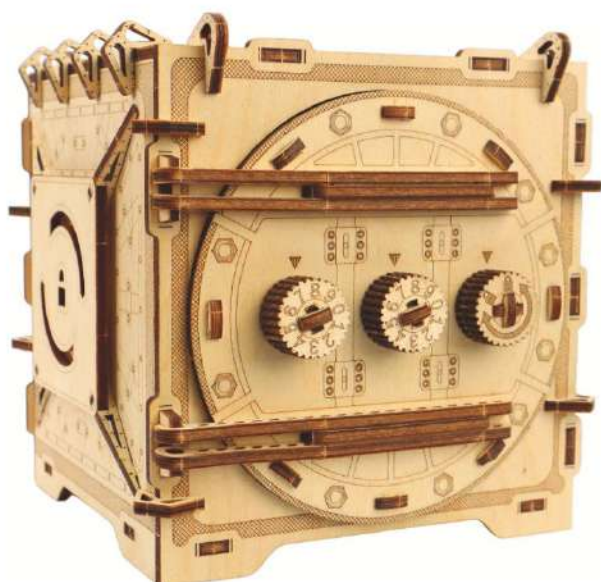

Сейф



Биг фут