

## POLINI Simple 101

- EN Baby cot
- DE Kinderbett
- NL Babybedje
- FR Lit d'enfant
- ES Cama juvenil
- IT Il letto da bambini
- P Cama juvenil
- RU Кроватка детская
- AE طفل المهد

# POLINI Simple 101

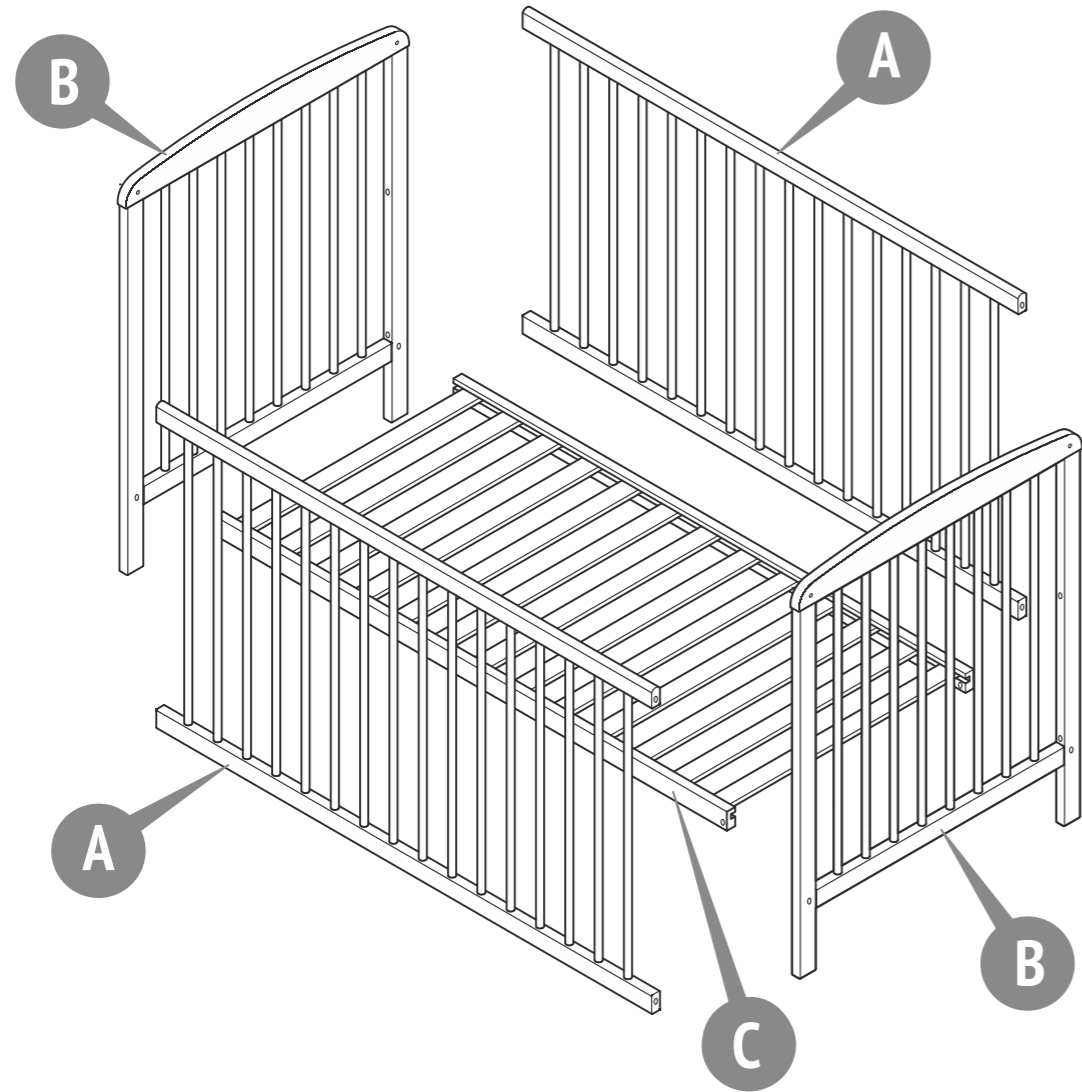

Number on the picture Nummer in der Zeichnung Nummer op figur Nombre à la figure Numero en el dibujo Il numero alla figura Número na figura Номер на рисунке الرقم على الرسمة	Number of parts in the product Stückzahl der Teile im Produkt Aantal componenten in het product Nombre des détails du produit Cantidad de elementos del producto La quantità dei dettagli nel prodotto Quantidade de peças Количество деталей в изделии كمية الأجزاء بالمنتج	Parts description Bezeichnung Onderdelen namen Names des pièces	Nombre de los elementos La nominazione dei dettagli Designação das peças Наименование деталей تسمية الأجزاء	Laying Verpackung Pakking Pose	El embalaje Posa Estilo Укладка	ترتيب
				Box / Karton / Plaats / Placer / Lugar / Il posto / Espaço / Место	المكان	1
A	2	Cot bed's side Seitenschutz De achterkant van het kinderbedje Butées latérales	La guía lateral Barriere da fianco Barra de segurança Боковое ограждение جانب السرير			•
B	2	Bed's back Kopfteil Kinderbett Rugleuning kinderbedje Tête du lit	El cabecero La spalliera del letto Cabeceira de cama Спинка кровати مسند سرير			•
C	1	Cot bed's bottom Lattenrost De onderkant van het kinderbedje Fond du lit	El fondo de la cuna Il fondo del letto Estrado de cama Дно кровати قاع السرير			•
	1	Set of fittings Satz Beschläge Hang-en-sluitwerk Kit d'accessoires	Conjunto de los accesorios Il completo della fornitura Kit de ferragens Комплект фурнитуры زاوية معدنية			•

001 8 x 

Screw M6 x 50  
Gewindschraube M6 x 50  
Schroef M6 x 50  
Vis M6 x 50  
Tornillo M6 x 50  
Vite M6 x 50  
Parafuso M6 x 50  
Винт M6 x 50  
المسمار M6 x 50

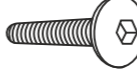
002 4 x 

Screw M6 x 50  
Gewindschraube M6 x 50  
Schroef M6 x 50  
Vis M6 x 50  
Tornillo M6 x 50  
Vite M6 x 50  
Parafuso M6 x 50  
Винт M6 x 50  
المسمار M6 x 50

003 8 x 

Round nut M6  
Rundmutter M6  
Ronde moer M6  
Ecrou baril M6  
La tuerca cilíndrica M6  
Dado barile M6  
Porca de tambor M6  
Гайка-бочонок M6  
جولة الجوز M6

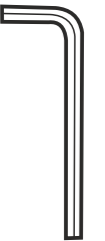

1

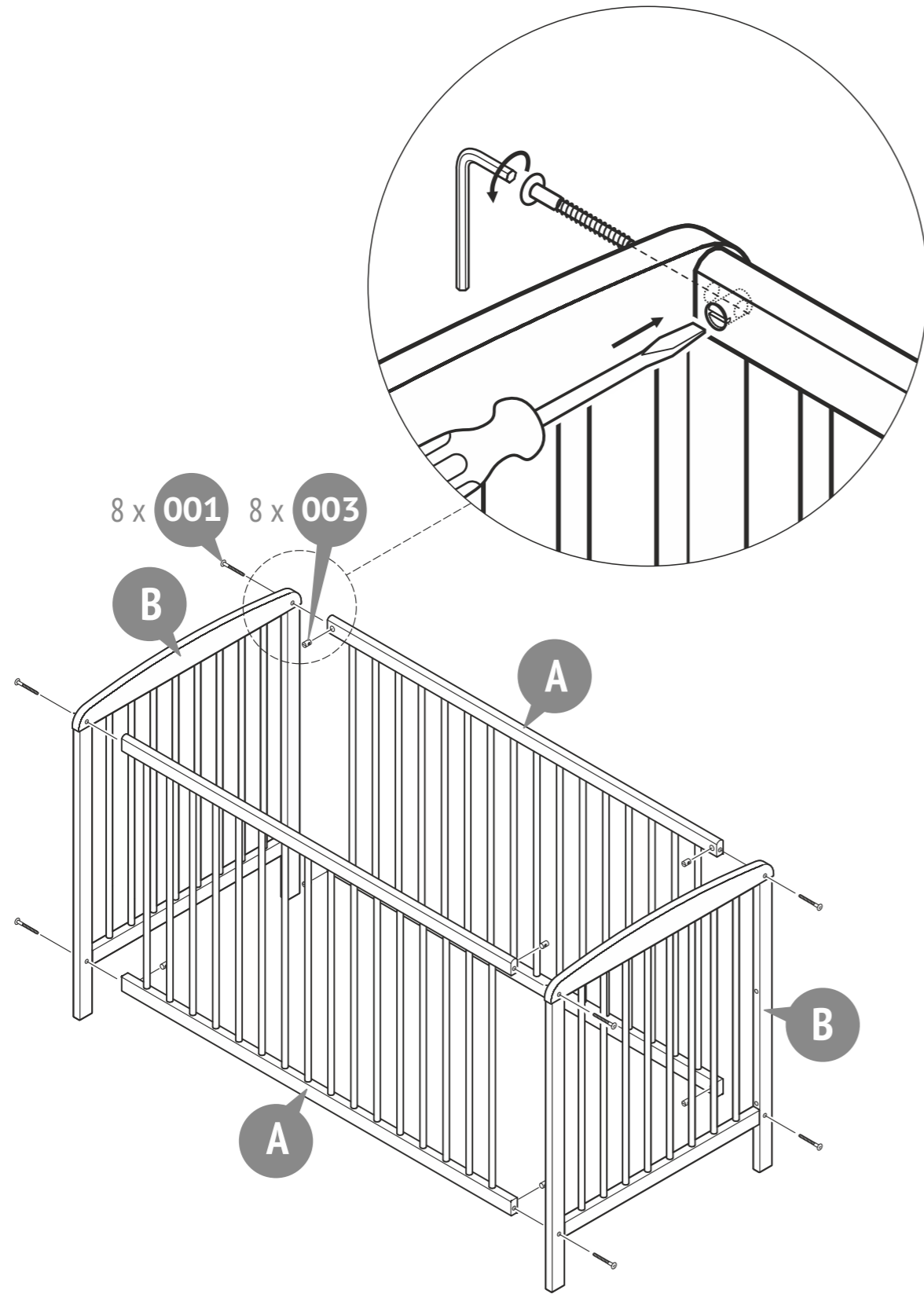

2

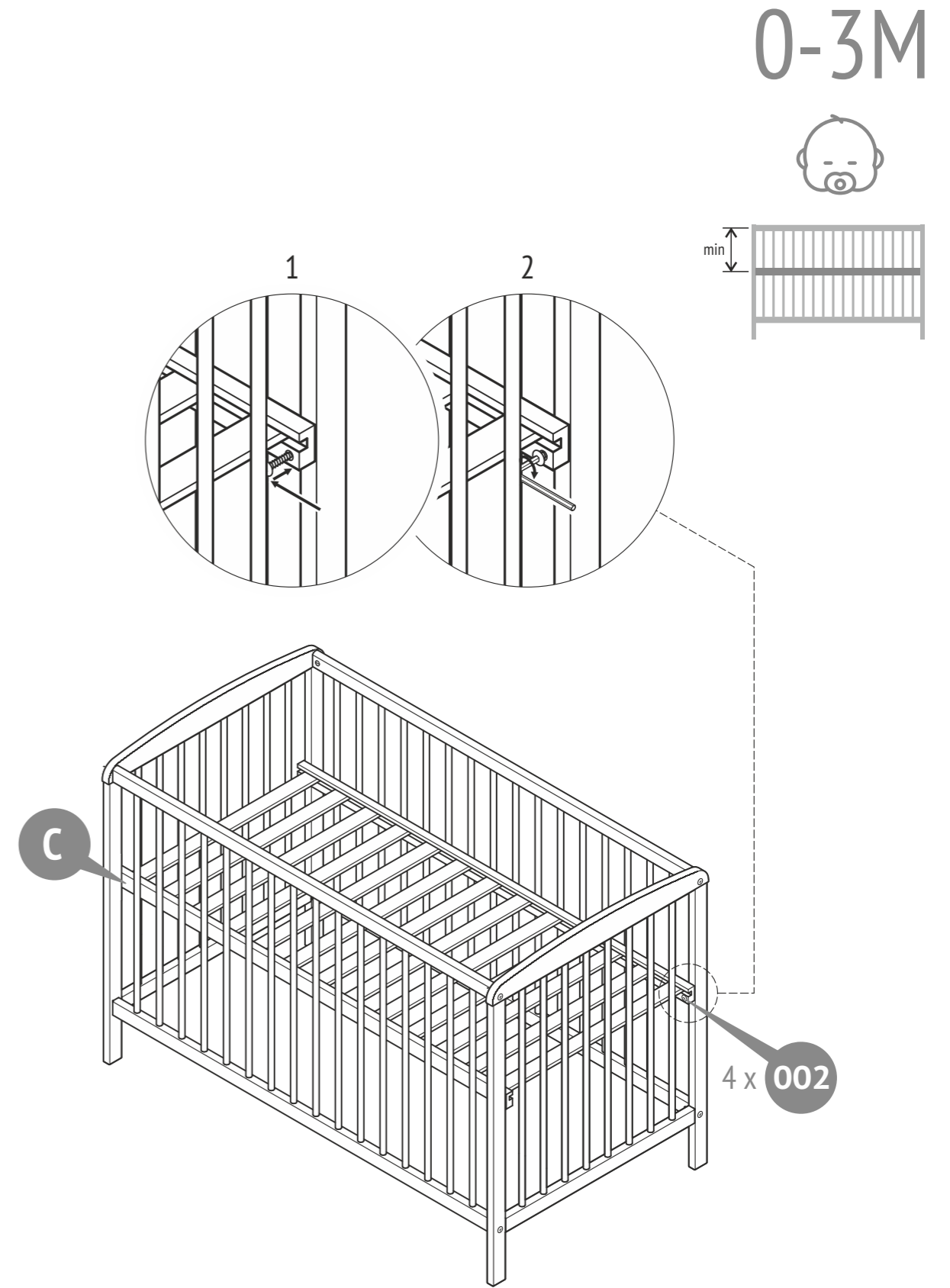

0-3M

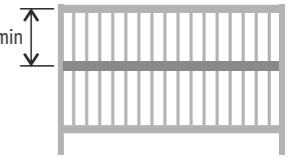

3

3M+

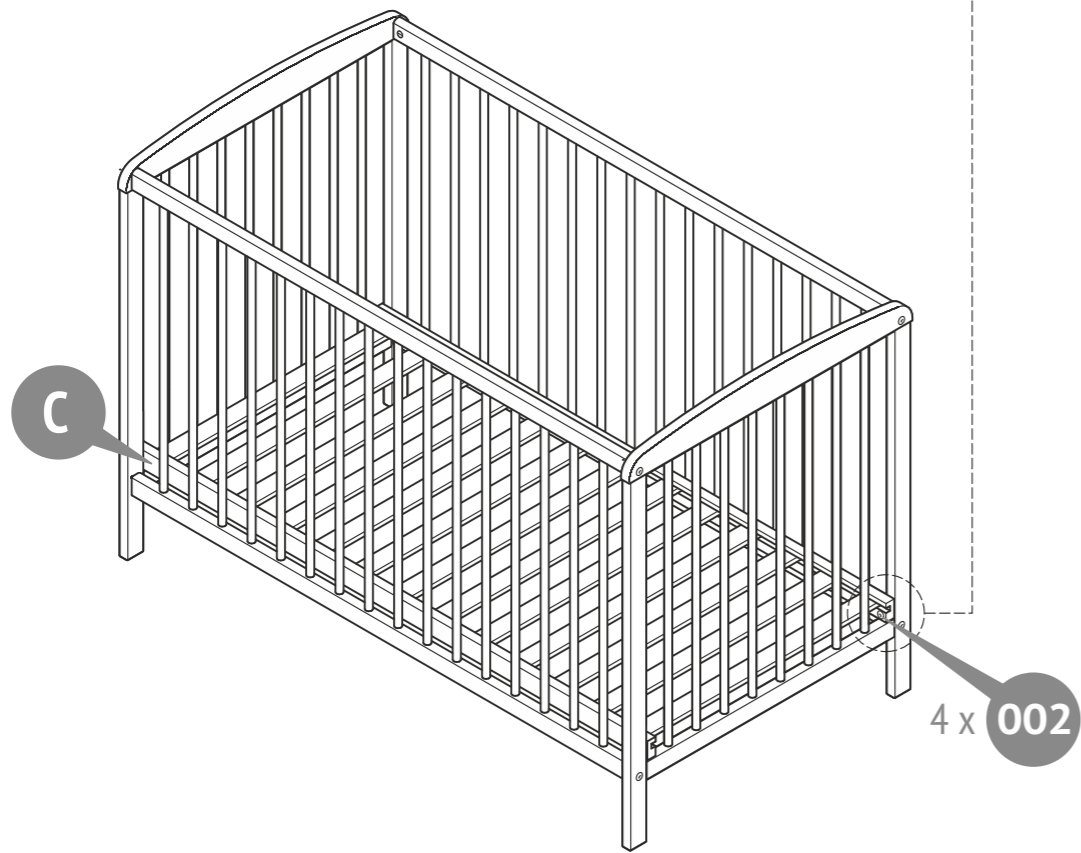
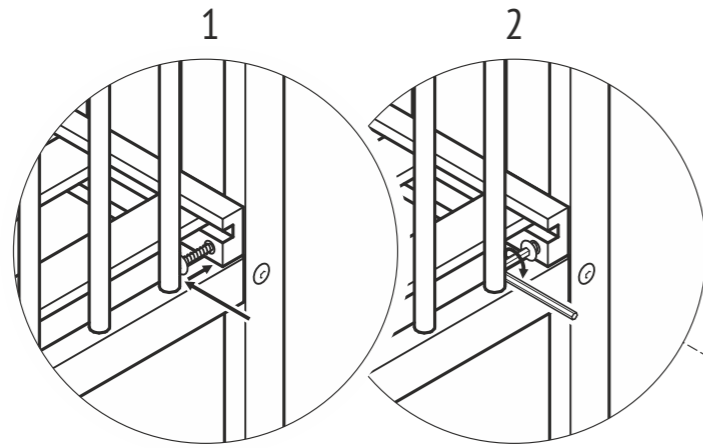
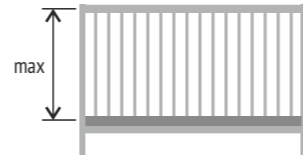

I

0-3M



II

3M+

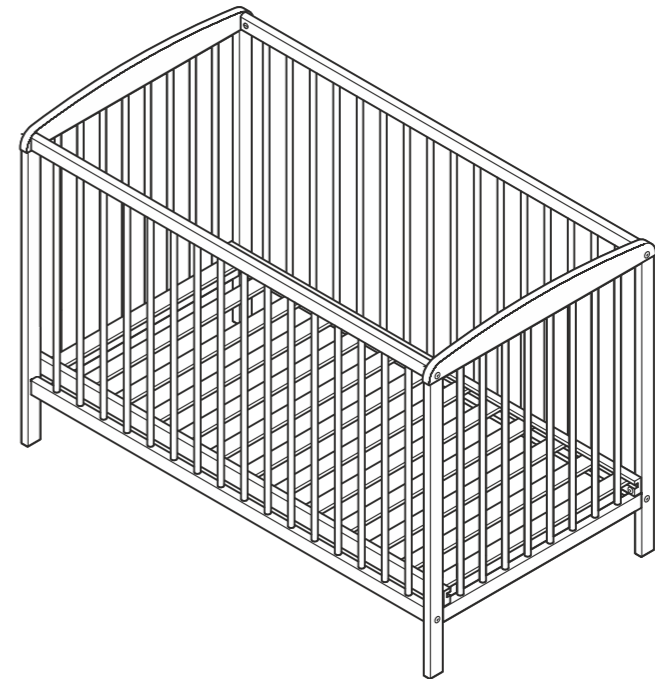

**EN** Minimum mattress size 1200 x 600 mm.  
Maximum thickness 100 mm.  
Do not use more than one mattress in cot.

**DE** Die Mindestgröße der Matratze 1200 x 600 mm.  
Die Maximale Höhe der Matratze 100 mm.  
Nie mehr als eine Matratze im Kinderbett benutzen.

**NL** Minimum matrasmaat 1200 x 600 mm.  
Maximale dikte 100 mm.  
Gebruik niet meer dan een matras in de babybedje.

**FR** La taille minimale du matelas 1200 x 600 mm.  
L'épaisseur maximale du matelas 100 mm.  
Ne pas utiliser plus d'un matelas dans le lit.

**ES** El tamaño mínimo del colchón 1200 x 600 mm.  
El espesor máximo 100 mm.  
No utilice más de un colchón en la cuna.

**IT** La misura minimale del materasso 1200 x 600 mm.  
Lo spessore massimale 100 mm.  
Non usate più di un materasso nel lettino.

**P** Tamanho mínimo do colchão 1200 x 600 mm.  
Espessura máxima 100 mm.  
Não utilize mais do que um colchão na cama.

**RU** Минимальный размер матраца 1200 x 600 мм.  
Максимальная толщина 100 мм.  
Не используйте более одного матраца в кроватке.

**AE** الحد الأدنى من حجم فراش 1200 x 600 ملم  
أقصى سمك 100 ملم  
لا تستخدم أكثر من واحد من فراش المهد